



**PRINTER'S REPAIR PARTS®**

REPLACEMENT PARTS FOR OFFSET PRINTING PRESSES

**Same Day Service**  
ORDERS RECEIVED BY  
2 P.M. WILL BE SHIPPED  
THE SAME DAY

**Top Quality**  
**Low Prices**

15th. REVISED EDITION  
DECEMBER, 2005

**\$ 50.00**

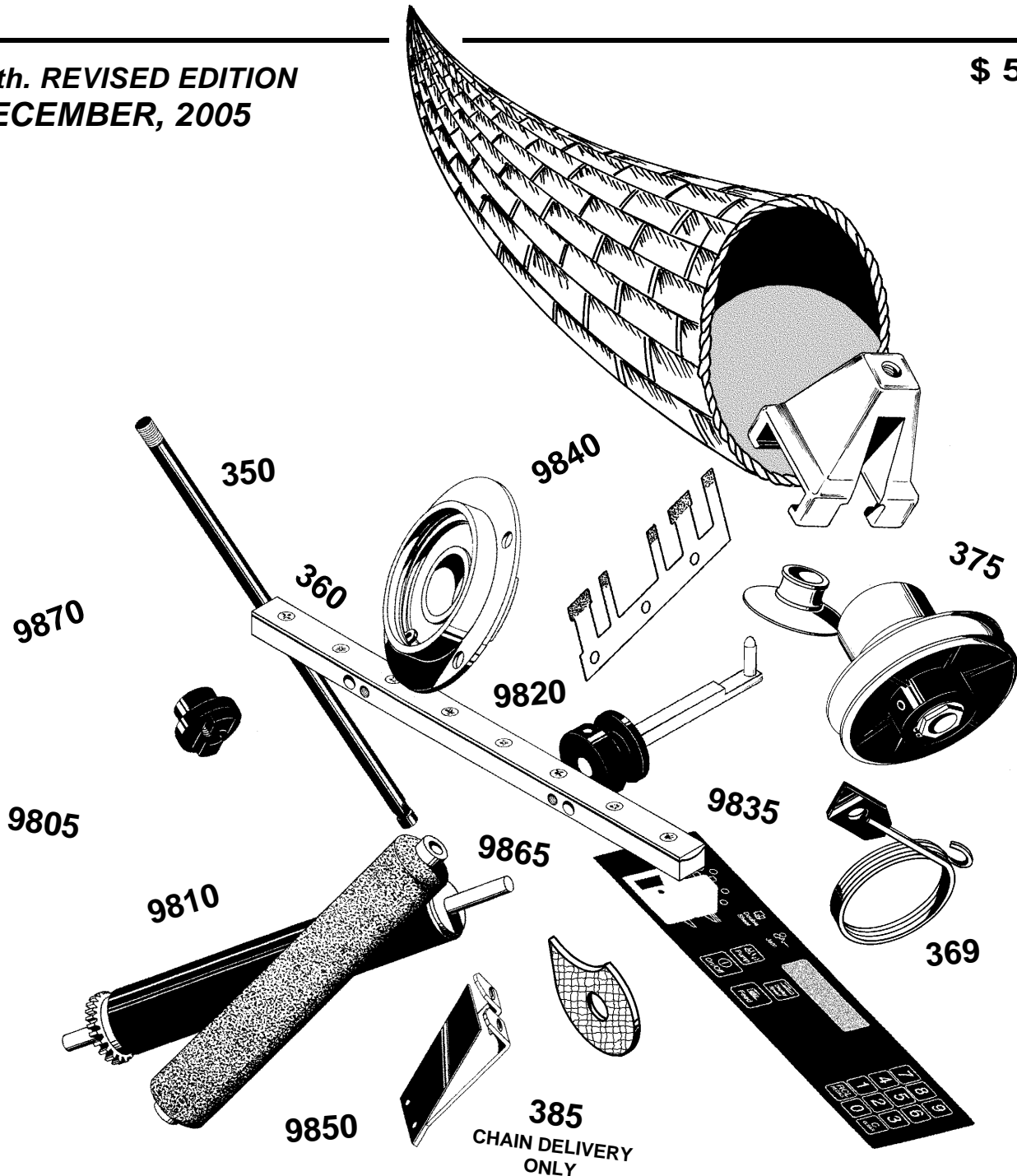

**REPLACEMENT PARTS CATALOG PART #P-AA**



**PRINTER'S REPAIR PARTS**®

REPLACEMENT PARTS FOR OFFSET PRINTING PRESSES

IF YOUR PRESS IS DOWN AND YOU NEED A PART  
RIGHT AWAY WE CAN SHIP IT TO YOU

- THE NEXT DAY (UPS RED LABEL)
- THE SECOND DAY (UPS BLUE LABEL)
- THE THIRD DAY (UPS ORANGE LABEL)

# **SURVIVAL KIT**

## **DESIGNED ESPECIALLY FOR THE A.B. DICK 350, 360 SERIES**

















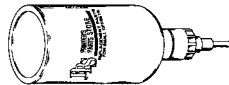







A KIT IS ALSO AVAILABLE FOR 9800 SERIES. CALL FOR INFO.

*Part #P-30838*

**PROBLEM:** PARTS WEAR OUT AND BREAK, AND THE DOWNTIME CAN COST YOU MONEY AND BUSINESS IF YOU'RE NOT PREPARED FOR IT.

**SOLUTION:** COMBAT DOWNTIME! KEEP YOUR MACHINE RUNNING AND THE JOBS FLOWING.

*Here's what you get in your kit:*

 <b>P-5088</b> (qty. 1) Combo Emergency Kit	 <b>P-36591</b> (qty. 1) Clutch Spring	 <b>P-36303</b> (qty. 1) Drive Switch	 <b>P-36307</b> (qty. 1) Toggle Switch	 <b>P-36581</b> (qty. 1) Drive Gear
 <b>P-36094</b> (qty. 1) Paper weight	 <b>P-1555</b> (qty. 50) Standard Sucker Foot	 <b>P-1915</b> (qty. 1) Bottle assembly	 <b>P-36446</b> (qty. 1) Brass Idler Gear	 <b>P-362320</b> (qty. 1) Back Stop Spring
 <b>P-36244</b> (qty. 2) Large Rubber Tire	 <b>P-36399</b> (qty. 2) Form Roll Tire	 <b>P-36990</b> (qty. 4) Sucker Tube-Shut Off	 <b>P-36174</b> (qty. 4) Sucker tube-Standard	 <b>P-36087</b> (qty. 1) Feeder Clamp
 <b>P-1539</b> (qty. 1) Feeder Clamp Screw	 <b>P-36088</b> (qty. 1) Side Spring Guide	 <b>P-36090</b> (qty. 1) Back Paper Guide	 <b>P-1549</b> (qty. 2) Water Fountain Hose	 <b>P-1189</b> (qty. 4) Blower Tube Hose
 <b>P-1180</b> (qty. 1) Make & Break Hose	 <b>P-36500</b> (qty. 1) Ink Ductor Cam Kit	 <b>P-1148</b> (qty. 4) Compressor Filter	 <b>P-1587</b> (qty. 1) 1/2 Pint of Oil	 <b>P-1833</b> (qty. 1) 14 oz. Can of Grease

**KIT ALSO INCLUDES 1 REPLACEMENT PARTS CATALOG FREE**

**SEE BACK INSIDE COVER OF THIS BOOK FOR  
THE SURVIVAL KIT FOR THE A.B. DICK 9800 SERIES**

# **SURVIVAL KIT**

## **DESIGNED ESPECIALLY FOR THE A.B. DICK 9800 SERIES**

















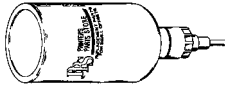

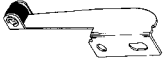





KITS ALSO AVAILABLE FOR 350, 360, AND 8800 SERIES. CALL FOR INFO.

*Part #P-30726*

**PROBLEM:** PARTS WEAR OUT AND BREAK, AND THE DOWNTIME CAN COST YOU MONEY AND BUSINESS IF YOU'RE NOT PREPARED FOR IT.

**SOLUTION:** COMBAT DOWNTIME! KEEP YOUR MACHINE RUNNING AND THE JOBS FLOWING.

*Here's what you get in your kit:*

 <b>P-5088 (qty. 1)</b> Combo Emergency Kit	 <b>P-36591 (qty. 1)</b> Clutch Spring	 <b>P-36303 (qty. 1)</b> Drive Switch	 <b>P-36307 (qty. 1)</b> Toggle Switch	 <b>P-1694 (qty. 1)</b> V-Belt
 <b>P-37094 (qty. 1)</b> Paper weight	 <b>P-1555 (qty. 50)</b> Standard Sucker Foot	 <b>P-1915 (qty. 1)</b> Bottle assembly	 <b>P-984279 (qty. 1)</b> Gate Spring-N.O.P.	 <b>P-984289 (qty. 1)</b> Gate Spring-Op. Side
 <b>P-36262 (qty. 2)</b> Ink Roller Seal	 <b>P-36500 (qty. 1)</b> Ink Ductor Cam Kit	 <b>P-36990 (qty. 4)</b> Sucker Tube-Shut Off	 <b>P-36174 (qty. 4)</b> Sucker tube-Standard	 <b>P-36087 (qty. 1)</b> Feeder Clamp
 <b>P-1539 (qty. 1)</b> Feeder Clamp Screw	 <b>P-36088 (qty. 1)</b> Side Spring Guide	 <b>P-36090 (qty. 1)</b> Back Paper Guide	 <b>P-1549 (qty. 2)</b> Water Fountain Hose	 <b>P-1189 (qty. 6)</b> Blower Tube Hose
 <b>P-1180 (qty. 1)</b> Make & Break Hose	 <b>P-983130 (qty. 2)</b> Star Wheel Tape	 <b>P-1148 (qty. 4)</b> Compressor Filter	 <b>P-1587 (qty. 1)</b> 1/2 Pint of Oil	 <b>P-1833 (qty. 1)</b> 14 oz. Can of Grease

**KIT ALSO INCLUDES 1 REPLACEMENT PARTS CATALOG FREE**

**SEE FRONT INSIDE COVER OF THIS BOOK FOR  
THE SURVIVAL KIT FOR THE A.B. DICK 350, 360 SERIES**

## IMPORTANT GENERAL INFORMATION

The parts catalog starts with -  
MOTORS & PUMPS, then FEEDER, CYLINDERS, INK, WATER, DELIVERY, PRINT CONTROLS,  
FEED CONTROLS, SUPPORT ARMS, POWER LEVERS, SIDE FRAMES, COVERS, SWITCH BOXES,  
**CHAIN DELIVERY** - MAIN SPROCKET ASSEMBLY, GRIPPER BARS & CHAINS, REAR CHAIN GUIDE,  
JOGGERS, PILE HEIGHT CONTROL, FRAMES, DOLLY BOARD & SAFETY GUARDS.

THIS CATALOG CONTAINS PARTS FOR BOTH CHUTE & CHAIN DELIVERY MODELS 350, 360, 369, 375, 9800  
AND MODEL 385 CHAIN DELIVERY ONLY.

All parts specifically for a 350 start with P-35000  
All parts for a 360 start with P-36000  
Any parts relative to all models will be listed as a P-36000 number.  
All parts specifically for a 375 start with P-37000  
All parts specifically for a 9800 start with P-98000

All parts included or needed for an assembly are indented beneath the part description.

EXAMPLE:	P-36984	<u>CAM LEVER ASSEMBLY</u>
	P-1593	<u>RIVET</u>
	P-1463	<u>CAM ROLLER</u>
	P-1579	<u>BUSHING</u>

PARTS ARE SOLD SEPARATELY, BUT YOU MUST HAVE PROPER TOOLS TO INSTALL.

ORDER BY PART NUMBERS ONLY. **DO NOT** ORDER BY FIGURE, INDEX OR KEY NUMBERS BECAUSE  
SOME **FIGURE** or **KEY** NUMBERS MAY HAVE MORE THAN ONE **PART** NUMBER DEPENDING  
ON THE MODEL PRESS.

WHEN ORDERING, PLEASE SPECIFY PARTS FOR OPERATORS SIDE OR NON-OPERATORS SIDE -  
NOT LEFT HAND OR RIGHT HAND.

### ABBREVIATIONS:

- |     |             |                          |
|-----|-------------|--------------------------|
| 1.  | O.D.        | = Outside diameter       |
| 2.  | I.D.        | = Inside diameter        |
| 3.  | O.A.L.      | = Overall length         |
| 4.  | V.          | = Volt                   |
| 5.  | Hz.         | = Cycles per second      |
| 6.  | S/N or S.N. | = Serial number          |
| 7.  | O.S.        | = Operators side         |
| 8.  | N.O.S.      | = Non-operators side     |
| 9.  | V.A.C.      | = Volt alternate current |
| 10. | DIA.        | = Diameter               |
| 11. | STD.        | = Standard               |

### NOTE:

For 9800 chain deliveries:  
9800 standard C.D.'s have aluminum cast frames,  
9800 1:1 C.D.'s have flat steel plate frames.

## TABLE OF CONTENTS

FIG.	DESCRIPTION
49	BASE FRAME & BOTTOM TIE BARS
13	BLANKET CYLINDER ASSEMBLY - 350, 360, 369, 9800
13A	BLANKET CYLINDER ASSEMBLY - 9805, 9850
14	BLANKET CYLINDER ASSEMBLY & PRINT ADJUSTMENT MECHANISM
35	BUCKLE ADJUSTING MECHANISM & COUNTER OPERATING LEVER
44	BUCKLE AND CAM SHAFT ASSEMBLY
55	CHAIN GUIDE IDLER SHAFT ASSEMBLY - (REAR)
55A	CHAIN GUIDE IDLER SHAFT ASSEMBLY - 9800, 1-1
52	CLOCK SYNCHRONIZER MECHANISM ASSEMBLY
65	COMPLETE CHAIN DELIVERY
3	COMPRESSOR & FILTER
2	COMPRESSOR MOTOR
4	COMPRESSOR TUBING & CONNECTIONS - 350, 360, 375
4A	COMPRESSOR TUBING & VALVE SYSTEM - 369, 9800
51	CONTROL PANEL ASSEMBLY - 9800
48A	CORDS- (POWER)
48	COVERS - BASE, REAR & R.H. PANEL DOOR
47	COVERS - UPPER SIDE, FEED & INK COVERS & COUNTER ASSEMBLY - 350, 360, 375
47A	COVERS - UPPER SIDE, FEED & INK COVERS & COUNTER ASSEMBLY - 9800
62	DOLLY BOARD & BACK STOP ASSEMBLY
54	DRIVE CHAIN, GRIPPER BARS & CHAIN SUPPORTS
1	DRIVE MOTOR & SPEED CONTROL - 350, 360, 369, 375
1A	DRIVE MOTOR & SPEED CONTROL - 9815, 9850
1B	DRIVE MOTOR & SPEED CONTROL - 9805, 9810
34	DRIVE SHAFT & CLUTCH PULLEY ASSEMBLY
31	EJECTOR ROLLER ASSEMBLY - (UPPER) - (CHUTE DELIVERY)
32	EJECTOR ROLLER - (LOWER) & STRIPPER ASSEMBLY - (CHUTE DELIVERY)
38	FEED CONTROL LEVERS & RELATED PARTS
7	FEED TABLE & PAPER GUIDES - 350, 360, 369, 375
8	FEED TABLE RAISING & ADJUSTING MECHANISM
11	FEEDER UNIT & IMPRESSION CYLINDER
23	FORM ROLLER (LOWER)& SINGLE LEVER CONTROL
22	FORM ROLLER (UPPER) & MANUAL CONTROL NIGHT LATCH
24A	FORM 3 - (SECTION #1)
24B	FORM 3 - (SECTION #2)
36	GAP CONTROL & GAP CONTROL INDICATOR
12	IMPRESSION CYLINDER - 350, 360, 369
12A	IMPRESSION CYLINDER - 375, 9800
40	IMPRESSION CYLINDER CONTROL & POWER LEVER
41	IMPRESSION CYLINDER SUPPORT ARMS & CYLINDER SHAFT
28	INK DUCTOR UNIT & GEARED INTERMEDIATE ROLLER
29A	INK FOUNTAIN UNIT & FOUNTAIN ROLLER - 350, 360, 369
29B	INK FOUNTAIN (METERING) UNIT & FOUNTAIN ROLLER - 360 PRO
29C	INK FOUNTAIN (METERING) UNIT & FOUNTAIN ROLLER - 9800 PRO
25	INK OSCILLATING ROLLER - (GEARED)
26	INK OSCILLATING ROLLER (TOP) & DISTRIBUTOR ROLLERS

## TABLE OF CONTENTS

FIG.	DESCRIPTION
26A	INK OSCILLATING ROLLER (LOWER) FOR 360 PRO & 9800 PRO
25	INK WASH-UP ATTACHMENT
50	LAMP, WASH-UP BOTTLE, GAUGES & SUPPLIES
53	MAIN SPROCKET ASSEMBLY, STAR BARS, STAR WHEELS & STAR WHEEL CLEANER ROLLER
53A	MAIN SPROCKET ASSEMBLY & PAPER GUIDES - 9800, 1-1
10	MAIN TIE BAR ASSEMBLY
15	MASTER (PLATE) CYLINDER ASSEMBLY - 350
16	MASTER (PLATE) CYLINDER ASSEMBLY - 360
17	MASTER (PLATE) CYLINDER ASSEMBLY - 369
17A	MASTER (PLATE) CYLINDER ASSEMBLY - 9800
42	MASTER CYLINDER SUPPORT ARMS & SHAFT
43	MASTER CYLINDER POWER LEVER & LATCH
7A	PAPER GUIDES - 9800
6	PAPER HEIGHT ADJUSTMENT MECHANISM
61	PART LOCATION REFERENCES - (CHAIN DELIVERY)
39	POWER LINK, FEED MECHANISM & TABLE RELEASE LEVER
47A	PROOF FEED SWITCH FOR 9800
56	REAR JOGGER & JOGGER CONTROL
56A	REAR JOGGER & JOGGER CONTROL - 9800, 1-1
58	RECEDING PILE CONTROL LEVER & GEARS
58A	RECEDING PILE CONTROL LEVER & GEARS - 9800, 1-1
33	RECIEVING TRAY ASSEMBLY - (CHUTE DELIVERY)
30	ROLLER KITS - WATER & INK
30A	ROLLER KITS - WATER & INK - (Continued)
63	SAFETY GUARDS, COVERS & SAFETY SWITCHES
64	SAFETY GUARDS, COVERS & SAFETY SWITCHES - (Continued)
46	SIDE FRAMES (UPPER & LOWER) TIE BARS & FRAME MOUNTS
45	SIDE FRAMES (UPPER INK) & RELATED PARTS
60	SIDE FRAMES & BASE ASSEMBLIES - (CHAIN DELIVERY)
57	SIDE JOGGERS & SIDE JOGGER CONTROL
57A	SIDE JOGGERS, SIDE JOGGER CONTROL & REAR JOGGER CONTROL - 9800, 1-1
37	SINGLE LEVER CONTROL
23	SINGLE LEVER CONTROL SHAFT ASSMEBLY
9	SUCKER FOOT MECHANISM & PAPER FEED ASSEMBLY
19	SUPER AQUAMATIC KIT - (ALCHOHOL SYSTEM)
27	SUPER INKER UNIT & ROLLER SCHEME
48A	SWITCHES - (DRIVE & PUMP) & SWITCH BOX
48B	SWITCHES - (MOMENTARY - DRIVE & PUMP)
48C	SWITCHES - (DRIVE & PUMP) POWER CORD & SWITCH BOX - 9805, 9810
59	TABLE RAISE SHAFT, CHAIN GUIDES & DOLLY BOARD SUPPORTS
59A	TABLE RAISE SHAFT, CHAIN GUIDES & DOLLY BOARD SUPPORTS - 9800 STANDARD, 9800, 1-1
5	VACUUM MAKE & BREAK CONTROL MECHANISM
20	WATER CONTROL LEVER ASSEMBLY
19	WATER FOUNTAIN ROLLER, BRACKETS & SUPER AQUAMATIC UNIT
18	WATER DUCTOR ROLLER & FOUNTAIN
21	WATER WAVER (OSCILLATING) ROLLER ASSEMBLY

DRAWING #1  
DRIVE MOTOR & SPEED CONTROL - 350, 360, 375

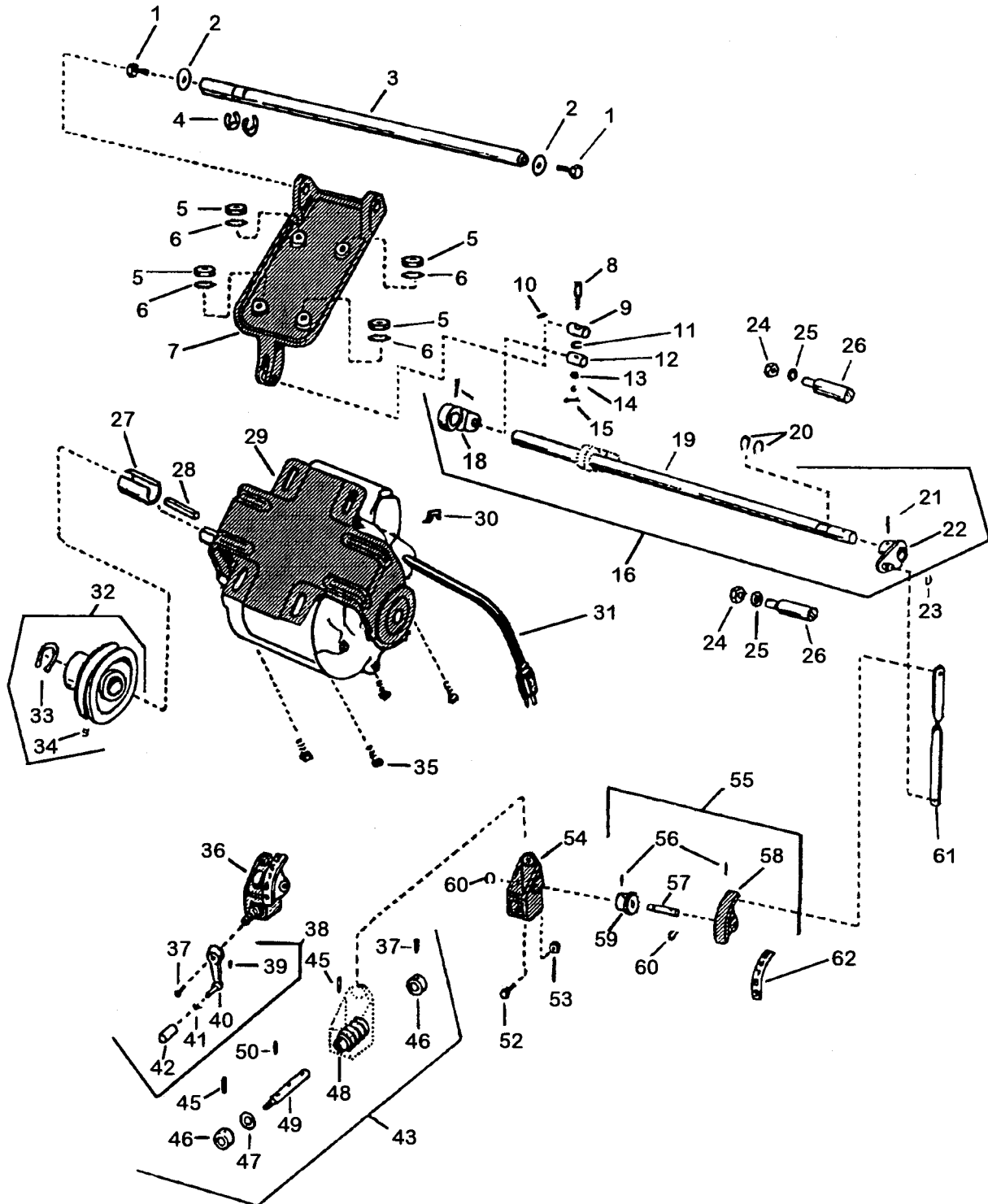



**PAGE #1**  
**DRIVE MOTOR & SPEED CONTROL - 350, 360, 375**

KEY #	PART#	DESCRIPTION
1	P-957	<u>SCREW</u>
2	P-597	<u>WASHER</u>
3	P-36040	<u>MOTOR MOUNT SHAFT</u> - ATTACHES TO TOP OF BASE FRAME SEE ITEM #26, PAGE 49.
4	P-674	<u>C-RING</u>
5	P-526	<u>ELASTIC LOCK NUT</u>
6	P-598	<u>LOCKWASHER</u> - NOT NECESSARY IF USING P-526 NUT.
7	P-36041	<u>CRADLE OR MOUNT</u> - FOR DRIVE MOTOR
8	P-36026	<u>SCREW</u> - SPEED CONTROL ADJUSTMENT
9	P-36028	<u>TRUNNION ADJUSTMENT NUT</u>
10	P-26	<u>SET SCREW</u> - FOR P-36028
11	P-700	<u>RETAINING RING</u> - FOR P-36026
12	P-36034	<u>TRUNNION NUT</u> - FOR ADJUSTMENT SCREW
13	P-569	<u>WASHER</u> - NOT NEEDED IF SPEED ADJUSTING SCREW DOES NOT HAVE A HOLE IN BOTTOM.
14	P-696	<u>RETAINING RING</u>
15	P-340	<u>COTTER PIN</u> - USED ONLY ON OLD STYLE ADJ. SCREW WITH WASHER P-569
16	P-36036	<u>SHAFT ASSEMBLY</u> - FOR MOTOR SPEED ADJ. PIVOT (ATTACHES TO BASE FRAME, ITEM #27, PAGE 49)
17	P-443	<u>TAPER PIN</u>
18	P-36037	<u>LEVER</u> - FOR MOTOR PIVOT SHAFT (NON OPERATOR'S SIDE) WITH PILOT HOLE ONLY, MUST HAVE PROPER TOOLS TO INSTALL OR SEE ASSM. P-36036
19	P-36038	<u>MOTOR PIVOT SHAFT</u> - ATTACHES TO BASE FRAME, SEE ITEM #27, PAGE 49. NO HOLES DRILLED, MUST HAVE PROPER TOOLS TO INSTALL OR SEE ASSM. P-36036
20	P-1054	<u>C-RING</u>
21	P-393	<u>ROLL PIN</u>
22	P-36039	<u>LEVER</u> - FOR MOTOR PIVOT SHAFT (OPERATOR'S SIDE) ATTACHES TO LINK ITEM #61, THIS PAGE.
23	P-703	<u>RETAINING RING</u>
24	P-497	<u>NUT</u> - NEEDS WASHER P-628
	P-496	<u>NUT</u> - NEEDS NO WASHER
25	P-628	<u>WASHER</u>
26	P-36044	<u>STUD</u> - MOTOR CONTROL STOP (NEED 2) ATTACHES TO BASE FRAME, SEE ITEM #29, PAGE 49.
	P-36045	<u>STUD</u> - MOTOR CONTROL STOP FOR 240V, 50HZ
27	P-36007	<u>SLEEVE</u> - NEEDED ONLY IF MOTOR HAS 1/2" DIA. SHAFT (FOR P-1700 MOTOR)
28	P-1190	<u>KEY</u> - MOTOR TO PULLEY
29	P-1700	<u>DRIVE MOTOR</u> - 115/230V, 60Hz, 1/3hp, (1/2" DIA. SHAFT, USES P-36007)
	P-1824	<u>DRIVE MOTOR</u> - 220V, 50Hz. 1/2hp 3 PHASE 1425 RPM
30	P-1644	<u>CORD STRAIN RELIEF</u> - NOT USED ON NEW MOTORS
31	P-4006	<u>MOTOR CORD</u> - 3 PIN PLUG. (USE A 3 PIN PLUG FOR A BETTER GROUND.) ATTACHES TO CORD ITEM 32, PG. 48A.
32	P-1630	<u>PULLEY ASSEMBLY</u> - 5/8" BORE, 3-1/2" MAJ. O.D., LIGHT TENSION - RUNS WITH DRIVE BELT ON ITEM #26, PAGE 34.
	P-5140	<u>PULLEY ASSEMBLY</u> - 5/8" BORE, 3-1/2" MAJ. O.D, HEAVY TENSION - RUNS WITH DRIVE BELT ON ITEM #26, PAGE 34.
	P-1631	<u>PULLEY ASSEMBLY</u> - 5/8" BORE, 3-3/8" MAJ. O.D., LIGHT TENSION - RUNS WITH DRIVE BELT, ITEM #26, PAGE 34.
	P-1649	<u>PULLEY ASSEMBLY</u> - 5/8" BORE, 4-1/4" MAJ. O.D., LIGHT TENSION - RUNS WITH DRIVE BELT, ITEM #26, PAGE 34.
33	P-710	<u>RETAINING RING</u>
	P-279	<u>RETAINING RING</u> - 240V, 50Hz
34	P-20	<u>SET SCREW</u>
35	P-1500	<u>SCREW</u> - MOTOR TO CRADLE, NEED 4.
36	P-36053	<u>INDICATOR ASSEMBLY</u> - (20 DEGREE PRESSURE ANGLE) ATTACH TO REAR LOWER SIDE FRAME, ITEM #37, PAGE 46. INCLUDES ITEMS #43, #54, #55, & #62.
	P-36012	<u>INDICATOR ASSEMBLY</u> - OLD STYLE. NO LONGER AVAILABLE, USE P-36053.
37	P-299	<u>SCREW</u>
38	P-36060	<u>CRANK ASSEMBLY</u> - <b>NOTE: WHEN REPLACING EITHER INDEX #48 OR #59, BOTH GEARS SHOULD BE REPLACED. PROPER TOOLS MUST BE USED TO INSTALL, USE REAMER BIT P-1590 &amp; HAND REAMER P-1546.</b>
39	P-10	<u>SET SCREW</u>
40	P-36061	<u>CRANK &amp; STUD</u>
41	P-36410	<u>LOCK SPRING</u>
42	P-36062	<u>HANDLE</u>
43	P-36025	<u>WORM &amp; SHAFT ASSEMBLY</u> - NEW STYLE (20° PRESSURE ANGLE)
	P-36013	<u>WORM &amp; SHAFT ASSEMBLY</u> - OLD STYLE (14-1/2° PRESSURE ANGLE)
44	P-382	<u>ROLL PIN</u>
45	P-434	<u>TAPER PIN</u>
46	P-739	<u>COLLAR</u> - NEED 2
47	P-1504	<u>SPRING WASHER</u>
48	P-36049	<u>WORM</u> - SEE NOTE - NEW STYLE (20° PRESSURE ANGLE)
	P-36014	<u>WORM</u> - SEE NOTE - OLD STYLE (14-1/2° PRESSURE ANGLE)
49	P-36051	<u>SHAFT</u>
50	P-380	<u>ROLL PIN</u>
51	P-672	<u>C-RING</u>
52	P-944	<u>SCREW</u>
53	P-487	<u>NUT</u>
54	P-36047	<u>HOUSING</u> - ATTACHES TO LOWER SIDE FRAME, SEE ITEM #37, PAGE 46.
55	P-36048	<u>GEAR &amp; SHAFT ASSEMBLY</u> - NEW STYLE (20° PRESSURE ANGLE)
	P-36015	<u>GEAR &amp; SHAFT ASSEMBLY</u> - OLD STYLE (14-1/2° PRESSURE ANGLE)
56	P-436	<u>TAPER PIN</u> - NEED 2
57	P-36052	<u>SHAFT</u>
58	P-36057	<u>DIAL INDICATOR LEVER</u>
59	P-36054	<u>MITER GEAR</u> - SEE NOTE - NEW STYLE (20° PRESSURE ANGLE)
	P-36016	<u>MITER GEAR</u> - SEE NOTE - OLD STYLE 14-1/2° PRESSURE ANGLE)
60	P-672	<u>RETAINING RING</u>
61	P-36058	<u>LINK</u> - TOP HOLE ATTACHES TO LEVER ITEM #22, BOTTOM HOLE ATTACHES TO DIAL INDICATOR ITEM #58, THIS PAGE.
62	P-36046	<u>DECAL</u> - INCLUDE WITH INDEX #58 PART # P-36057
63	P-1590	<u>REAMER BIT</u>
64	P-1546	<u>HAND REAMER</u>

**DRAWING #1A**  
**DRIVE MOTOR & SPEED CONTROL - 9815, 9850**

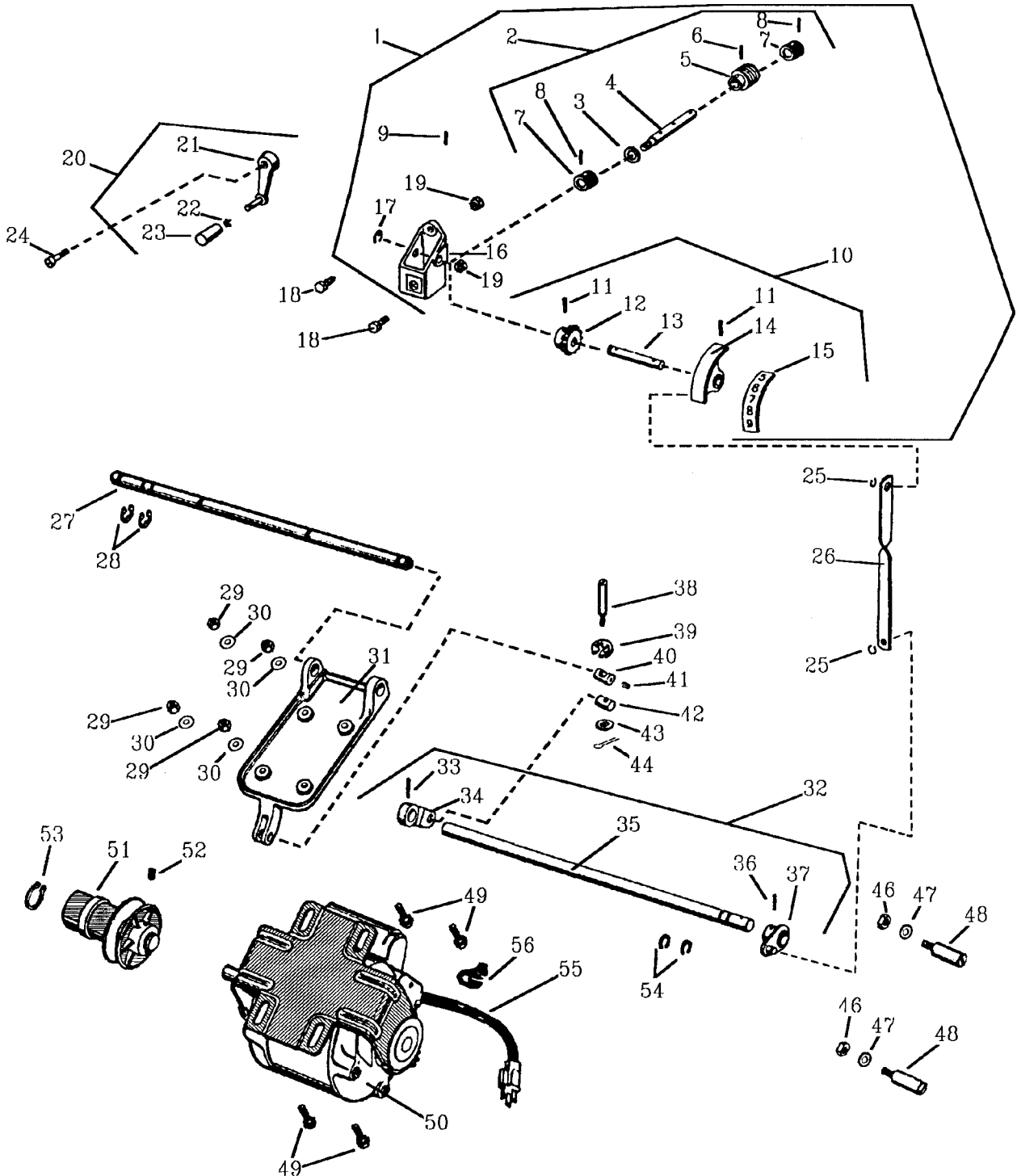

**PAGE #1A**  
**DRIVE MOTOR & SPEED CONTROL - 9815, 9850**

KEY #	PART#	DESCRIPTION
1	P-36053	<u>INDICATOR ASSEMBLY</u> - (20° PRESSURE ANGLE) ATTACHES TO REAR LOWER SIDE FRAME, ITEM #37, PAGE 46. ITEMS 17, 18, & 19 NOT INCLUDED WITH INDICATOR ASSEMBLY.
2	P-36025	<u>WORM GEAR &amp; SHAFT ASSEMBLY</u> - NEW STYLE - 20½ PRESSURE ANGLE
3	P-1504	<u>SPRING WASHER</u>
4	P-36051	<u>SHAFT</u>
5	P-36049	<u>WORM GEAR</u> - NEW STYLE - 20° PRESSURE (SEE NOTE).
6	P-434	<u>TAPER PIN</u>
7	P-739	<u>COLLAR</u> - NEED 2
8	P-382	<u>ROLL PIN</u>
9	P-380	<u>ROLL PIN</u> (NOT INCLUDED WITH ITEM #2, THIS PAGE.)
10	P-36048	<u>GEAR &amp; SHAFT ASSEMBLY</u>
11	P-436	<u>TAPER PIN</u>
12	P-36054	<u>MITER GEAR</u> -NEW STYLE - 20° PRESSURE ANGLE.
13	P-36052	<u>SHAFT</u>
14	P-36057	<u>DIAL INDICATOR LEVER</u>
15	P-36046	<u>DECAL</u>
16	P-36047	<u>HOUSING</u> - ONLY INCLUDED IN FULL INDICATOR ASSEMBLY, ITEM #1, THIS PAGE.
17	P-672	<u>C-RING</u>
18	P-944	<u>SCREW</u> - FOR MOUNTING HOUSING
19	P-487	<u>NUT</u> - FOR MOUNTING HOUSING
20	P-98060	<u>HAND CRANK ASSEMBLY</u> - 9800 ONLY
21	P-98061	<u>CRANK HANDLE</u> - 9800 ONLY
22	P-36410	<u>LOCK SPRING</u>
23	P-36062	<u>HANDLE</u>
24	P-1994	<u>SCREW</u>
25	P-703	<u>RETAINING RING</u>
26	P-36058	<u>LINK</u>
27	P-37040	<u>SHAFT</u> - MOTOR MOUNT - 375 - ATTACHES TO BASE FRAME, SEE ITEM #26, PAGE 49.
	P-98040	<u>SHAFT</u> - MOTOR MOUNT - 9800 - ATTACHES TO BASE FRAME, SEE ITEM #26, PAGE 49.
28	P-674	<u>C-RING</u>
29	P-526	<u>ELASTIC LOCK NUT</u>
30	P-598	<u>WASHER</u>
31	P-36041	<u>CRADLE OR MOUNT</u>
32	P-37036	<u>SHAFT ASSEMBLY</u> - 375 & 9800
33	P-443	<u>TAPER PIN</u>
34	P-36037	<u>LEVER</u>
35	P-37038	<u>SHAFT</u> - NOT SOLD SEPARATELY. USE P-37036 SHAFT ASSEMBLY, ITEM #32, THIS PAGE.
36	P-393	<u>ROLL PIN</u>
37	P-36039	<u>LEVER</u> - FOR MOTOR PIVOT SHAFT (OPERATORS SIDE) ATTACHES TO LINK, ITEM #26, THIS PAGE. NOT SOLD SEPARATELY. USE P-37036 SHAFT ASSEMBLY, ITEM #26, THIS PAGE.
38	P-36031	<u>SCREW</u> - CRADLE ADJUSTMENT - NEW STYLE
39	P-700	<u>RETAINING RING</u>
40	P-36028	<u>TRUNNION ADJUSTMENT NUT</u>
41	P-26	<u>SET SCREW</u>
42	P-36034	<u>NUT</u>
43	P-569	<u>WASHER</u>
44	P-340	<u>COTTER PIN</u>
46	P-496	<u>NUT</u> - NEEDS NO WASHER
	P-497	<u>NUT</u> - NEEDS WASHER P-628
47	P-628	<u>WASHER</u>
48	P-36044	<u>STUD</u> - MOTOR CONTROL STOP - ATTACHES TO BASE FRAME, SEE ITEM #29, PAGE 49.
	P-36045	<u>STUD</u> - MOTOR CONTROL STOP - ATTACHES TO BASE FRAME, SEE ITEM #29, PAGE 49.
49	P-1500	<u>BOLT</u>
50	P-1700	<u>MOTOR</u> - 1/3 H.P. 115/230V. 60HZ.
	P-1636	<u>MOTOR</u> - 3/4 H.P. 110/115/200/230V. 50 /60HZ. 1 CPACITOR.
	P-4088	<u>MOTOR</u> - 1/3 H.P. 115/230V. 50/60HZ. 2 CAPCITOR.
	P-1634	<u>MOTOR</u> - 1/3 H.P. 100/200V. 50/60HZ.
51	P-1630	<u>PULLEY</u> - VARIABLE SPEED - 3/8" BELT, 1/3 H.P. 115V. 60HZ.
	P-1649	<u>PULLEY</u> - VARIABLE SPEED - 3/8" BELT, 1/2-1/3 H.P. 50HZ.
	P-1751	<u>PULLEY</u> - VARIABLE SPEED - 1/2" BELT, OLD DESIGN, 3/4 H.P. 50HZ.
52	P-20	<u>SET SCREW</u>
53	P-710	<u>RETAINING RING</u>
54	P-1054	<u>C-RING</u>
55	P-4006	<u>MOTOR CORD</u> - 3 PIN PLUG
56	P-1644	<u>STRAIN RELIEF</u>

**DRAWING #1B**  
**DRIVE MOTOR & SPEED CONTROL - 9805, 9810**

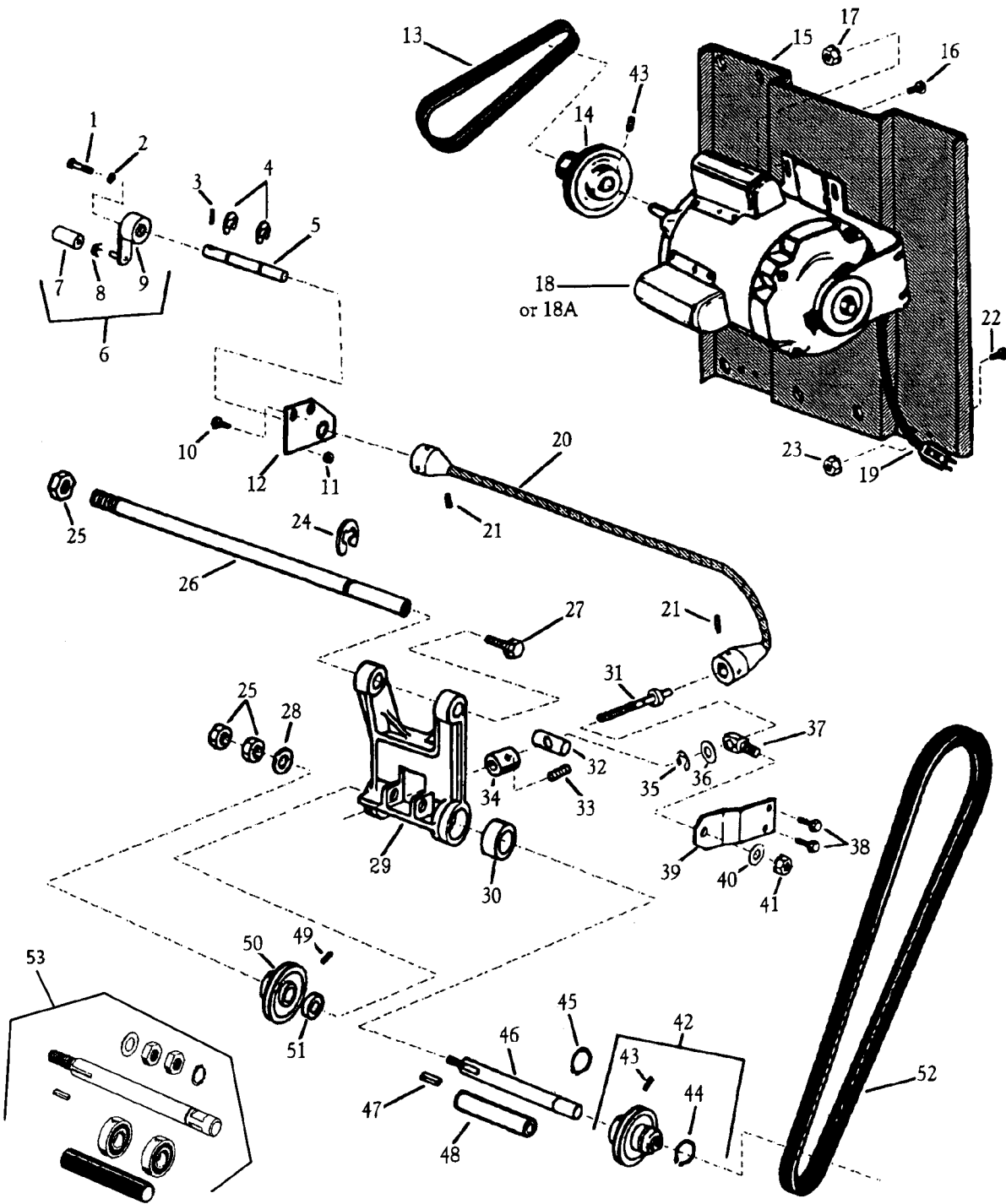

**PAGE #1B**  
**DRIVE MOTOR & SPEED CONTROL - 9805, 9810**

KEY #	PART#	DESCRIPTION
1	P-1994	<u>SCREW</u>
2	P-1495	<u>O-RING</u>
3	P-380	<u>ROLL PIN</u>
4	P-670	<u>C-RING</u>
5	P-98051	<u>SHAFT - SPEED CONTROL</u>
6	P-98060	<u>CRANK ASSEMBLY</u>
7	P-36062	<u>KNOB</u>
8	P-36410	<u>LOCK SPRING</u>
9	P-98061	<u>HANDLE</u>
10	P-82	<u>SCREW</u>
11	P-472	<u>NUT</u>
12	P-98047	<u>PLATE ASSEMBLY</u>
13	P-1679	<u>21" V- BELT - CONNECTS TO ITEMS #14 &amp; #50, THIS PAGE.</u>
14	P-1630	<u>VARIABLE SPEED PULLEY - DRIVES PULLEY ITEM #50, THIS PAGE.</u>
15	P-98162	<u>PANEL - REAR (FOR MOTOR MOUNT)</u>
16	P-956	<u>SCREW - FOR MOTOR MOUNT</u>
17	P-526	<u>NUT - FOR MOTOR MOUNT</u>
18	P-1636	<u>DRIVE MOTOR - 3/4 HP. - 100-115/200-230V. - 50/60 Hz. - 1/2" SHAFT. 1 CAPACITOR.</u>
18A	P-4088	<u>DRIVE MOTOR - 3/4 HP. - 100-115/200-230V. - 50/60 Hz. - 1/2" SHAFT.</u>
19	P-4006	<u>CORD</u>
20	P-98053	<u>FLEXIBLE SHAFT - 18" LONG.</u>
21	P-7	<u>SET SCREW</u>
22	P-948	<u>SCREW</u>
23	P-487	<u>NUT</u>
24	P-1054	<u>C-RING</u>
25	P-514	<u>NUT</u>
26	P-98040	<u>MOTOR MOUNT SHAFT</u>
27	P-957	<u>SCREW</u>
28	P-613	<u>WASHER</u>
29	P-98041	<u>CRADLE - SEE ITEM #53</u>
30	P-5802	<u>BEARING</u>
31	P-98026	<u>SPEED CONTROL SHAFT ASSEMBLY - TRUNNION ADJUSTMENT.</u>
32	P-98028	<u>TRUNNION ADJUSTMENT NUT</u>
33	P-9	<u>SET SCREW</u>
34	P-98137	<u>COLLAR</u>
35	P-670	<u>C-RING</u>
36	P-604	<u>WASHER</u>
37	P-98034	<u>ADJUSTMENT POST</u>
38	P-92	<u>SCREW</u>
39	P-98043	<u>SHAFT SUPPORT PLATE</u>
40	P-610	<u>WASHER</u>
41	P-503	<u>NUT</u>
42	P-5140	<u>VARIABLE SPEED PULLEY</u>
43	P-20	<u>SET SCREW</u>
44	P-710	<u>RETAINING RING</u>
45	P-707	<u>RETAINING RING</u>
46	P-98038	<u>SHAFT - INCLUDED WITH CRADLE REPAIR KIT, ITEM #53, THIS PAGE.</u>
47	P-1745	<u>KEY</u>
48	P-98058	<u>SPACER</u>
49	P-5364	<u>SET SCREW</u>
50	P-1746	<u>PULLEY</u>
51	P-1814	<u>WASHER</u>
52	P-4917	<u>50" V- BELT - CONNECTS TO ITEM #42, THIS PAGE - AND ITEM #12, PAGE 34.</u>
53	P-98037	<u>CRADLE ASSEMBLY REPAIR KIT - FOR 8800 &amp; 9800 SERIES.</u> "RATHER THAN BUY A COMPLETE CRADLE ASSEMBLY, WE SELL A KIT TO REPAIR YOUR EXISTING CRADLE. NORMALLY THE CRADLE ITSELF DOESN'T WEAR OUT BUT THE PARTS DO." Consists of: 1) P-613 WASHER, ITEM #28 2) P-514 NUT, ITEM #25 1) P-707 RING, ITEM #45 1) P-98038 SHAFT, ITEM #46 2) P-11149 BEARINGS, ITEM #30 1) P-98058 SLEEVE, ITEM #48 1) P-1745 KEY, ITEM #47

DRAWING #2  
COMPRESSOR MOTOR

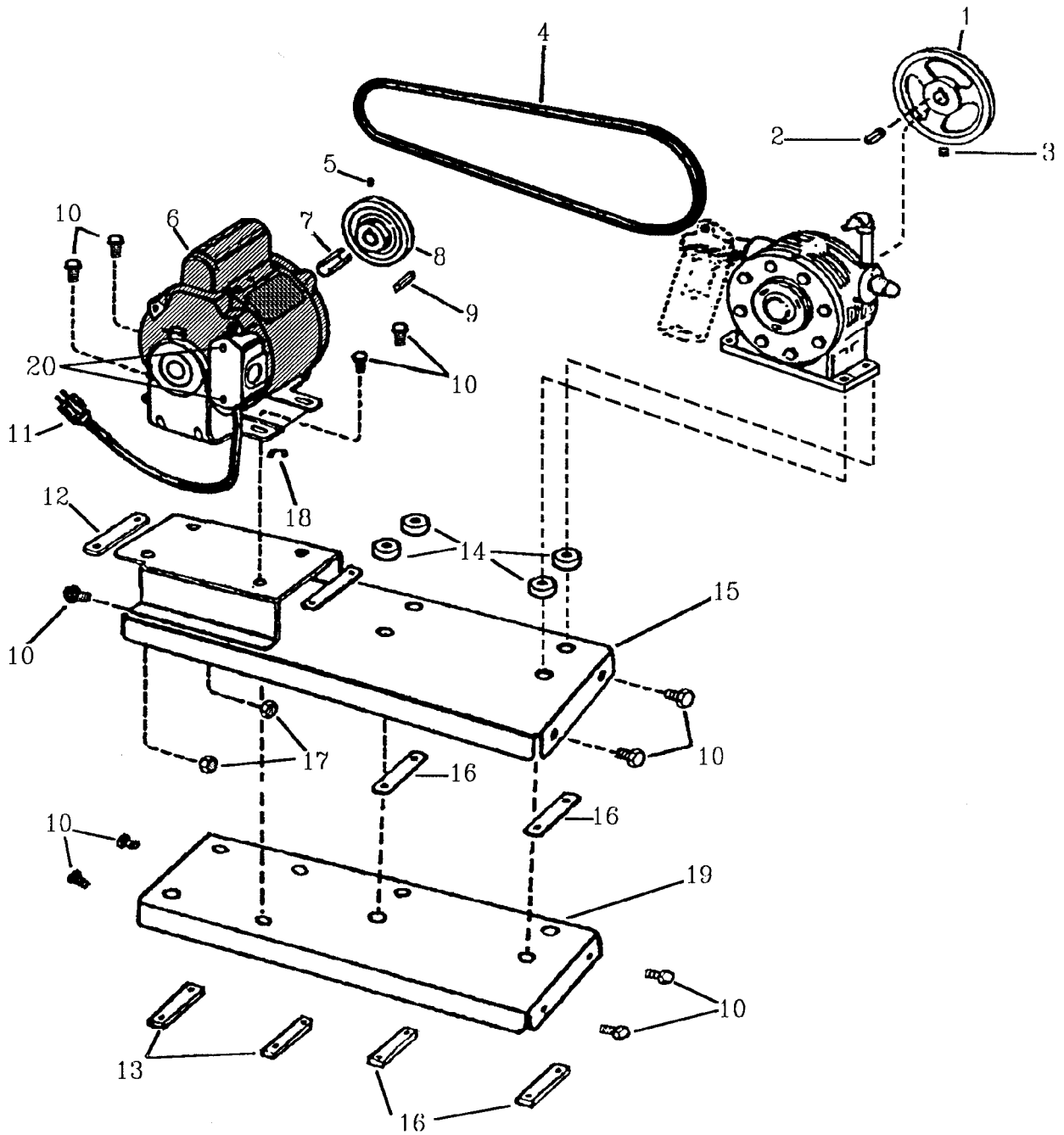

**PAGE #2**  
**COMPRESSOR MOTOR**

KEY #	PART#	DESCRIPTION
1	P-1161	<u>COMPRESSOR PULLEY</u>
2	P-1171	<u>KEY</u> - FOR PULLEY'S P-1161, P-1599 & P-1642.
3	P-32	<u>SET SCREW</u> - FOR PULLEY P-1161.
4	P-1637	<u>30" V BELT</u> - 115V, 60HZ, FOR FLAT BASE OR A RAISED BASE 363 .
	P-1638	<u>33" V BELT</u> - 115V, 60HZ, FOR RAISED BASE.
(*)	P-1639	<u>31" V BELT</u> - 115V/230V, 50HZ, FOR FLAT BASE.
	P-1640	<u>29" V BELT</u> - FOR 230V, 60HZ FOR FLAT BASE.
	P-1680	<u>27" V BELT</u> - 375 - 115V 60HZ. RAISED BASE.
5	P-875	<u>SET SCREW</u> - FOR PULLEYS P-1599 & P-1642.
6	P-1700	<u>MOTOR</u> - 115/230V,, 60HZ, 1/3 hp,(1/2" DIA. SHAFT, USES P-36007 SLEEVE) .
(*)	P-1634	<u>MOTOR</u> - 115V/230V, 50HZ, 1/2" DIA. SHAFT 1/3 hp.
	P-1825	<u>MOTOR</u> - 3 PHASE 210/220V, 50/60HZ, 1/2" DIA. SHAFT 1/3 hp.
	P-1636	<u>MOTOR</u> - 115V, 60HZ, 3/4 hp, 5/8" SHAFT.
	P-1972	<u>MOTOR</u> - 100/115V, 50/60HZ. - 9800 ONLY .
7	P-36007	<u>SLEEVE</u> - NEEDED ONLY IF MOTOR HAS 1/2" DIA. SHAFT (i.e. P-36004).
8	P-1599	<u>PULLEY</u> - 350/360 - FOR COMPRESSOR MOTOR, 115V/230V, 3-3/16" KEY, 3-1/2" DIA., 5/8" BORE.
(*)	P-1642	<u>PULLEY</u> - 350/360 - FOR 50HZ MOTOR, 3-3/16" KEY, 4-1/4" DIA., 5/8" BORE.
	P-1359	<u>PULLEY</u> - 375 ONLY 5/8" BORE, 3-3/16" KEY, 4-1/4" DIA.
9	P-1190	<u>KEY</u> - FOR MOTOR PULLEY P-1631, SEE ITEM #32, PAGE 1.
10	P-951	<u>BOLT</u> - MOTOR MOUNTING.
11	P-4006	<u>CORD</u> - 3 PIN PLUG (THE 3 PIN PLUG PROVIDES A BETTER GROUND) ATTACHES TO CORD. ITEM #30, PAGE 48A.
12	P-36017	<u>NUT PLATE</u> - FOR RAISED BASE, UNDER MOTOR 375/9800, 2-3/4" CENTER
13	P-36008	<u>NUT PLATE</u> - FOR FLAT BASE, 3/4 hp. MOTOR PLATE, 3" CENTER.
14	P-1144	<u>GROMMET</u> - SHOULD REPLACE ALL 4.
15	P-36001	<u>RAISED BASE</u> - FOR MOTOR & COMPRESSOR, ATTACHES TO BOTTOM OF BASE FRAME, PAGE 49, (360).
	P-37001	<u>RAISED BASE</u> - FOR MOTOR & COMPRESSOR, ATTACHES TO BOTTOM OF BASE FRAME, PAGE 49, (375).
16	P-36009	<u>NUT PLATE</u> - FOR FLAT OR RAISED BASE, MOUNTS UNDER PUMP OR COMPRESSOR.
17	P-492	<u>NUT</u>
18	P-1644	<u>STRAIN RELIEF</u>
19	P-36002	<u>FLAT BASE</u> - FOR MOTOR & COMPRESSOR, ATTACHES TO BOTTOM OF BASE FRAME,PAGE 49.
20	P-112	<u>SCREW</u> - USE ON P-1634, 1700 & P-1636 MOTORS.
... <b>NOTE:</b> (*) INDICATES FOR PRESSES OPERATING WITH 50 HZ MOTORS		

**DRAWING #3**  
**COMPRESSOR & FILTER**

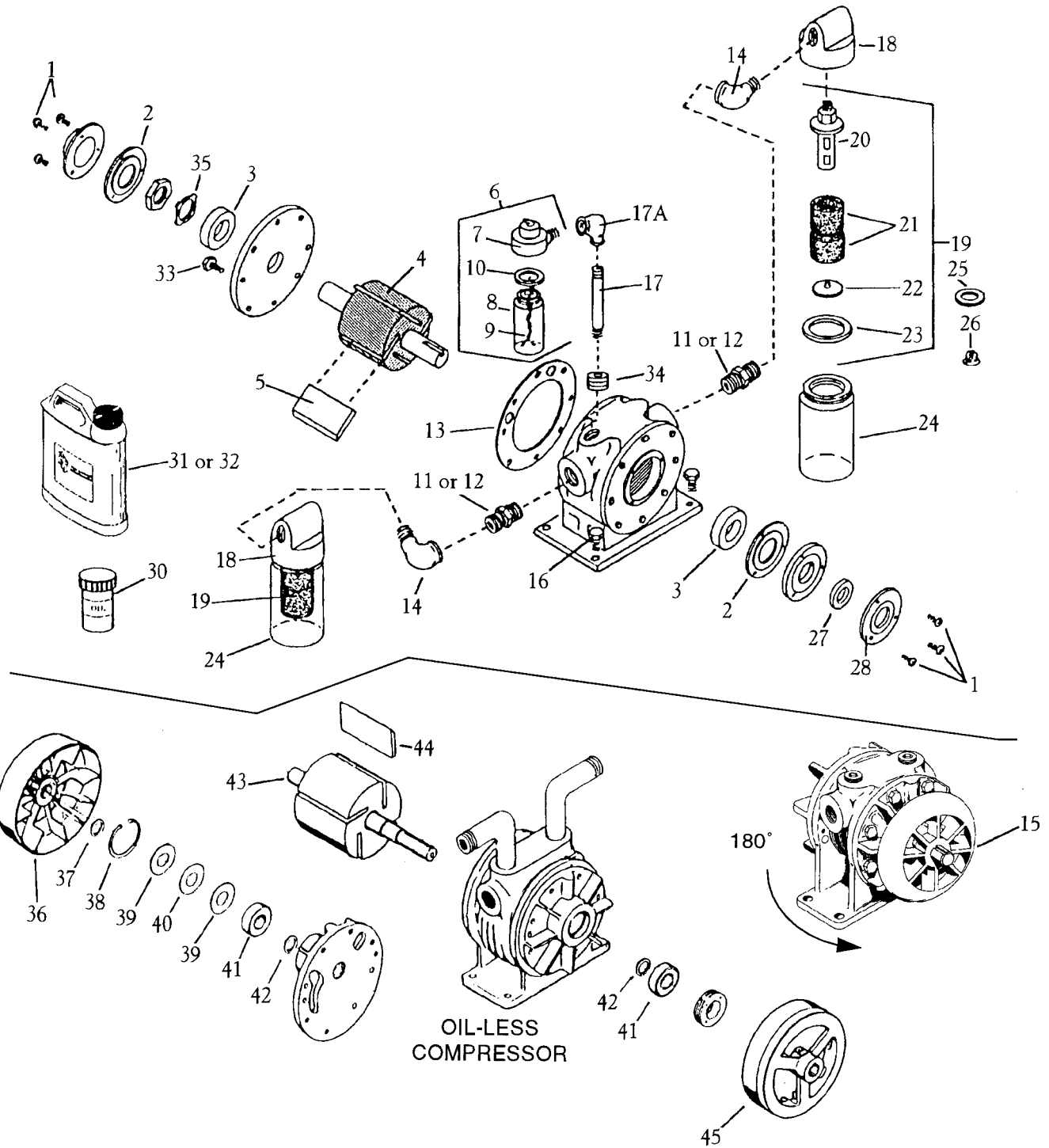



**PAGE #3**  
**COMPRESSOR & FILTER**

KEY #	PART#	DESCRIPTION
1	P-131	<u>SCREW</u>
2	P-1166	<u>OIL GASKET</u> - 2 INSIDE COMPRESSOR
3	P-790	<u>BALL BEARING</u> - 2 INSIDE COMPRESSOR
4	P-1167	<u>ROTOR</u>
5	P-1159	<u>VANE</u> - FOR COMPRESSOR USING OIL. SHOULD REPLACE ALL 4, SEE ITEM # 29 FOR **COMPLETE** REPAIR KIT.
6	P-1145	<u>OILER ASSEMBLY</u> - OIL CAP, GASKET, WICK & JAR. NOT NEEDED ON OIL-LESS COMPRESSOR.
7	P-1153	<u>COVER</u> - NOT AVAILABLE SEPERATELY. USE P-1145 ITEM #6.
8	P-1156	<u>OIL JAR</u>
9	P-1155	<u>WICK</u> - FOR SMALL OIL BOTTLE
10	P-1154	<u>GASKET</u> - SMALL OILER BOTTLE
11	P-1170	<u>REDUCING NIPPLE</u> - FROM 1/2" TO 3/8", NEEDED ON LARGE CAPACITY GAST COMPRESSORS ONLY, NEED 2, 1 FOR EACH SIDE.
12	P-1163	<u>NIPPLE</u> - 1" STEEL, BOTH ENDS ARE THREADED.
13	P-1158	<u>GASKETS</u> - 2 INSIDE COMPRESSOR.
14	P-1174	<u>ELBOW</u> - 90 DEGREE
15	P-1645	<u>OIL-LESS COMPRESSOR</u> - (SEE COMPRESSOR ON PAGE 2). <b>THIS IS A NOW A NEW STYLE OIL-LESS COMPRESSOR WHICH TAKES THE PLACE OF THE OLD STYLE COMPRESSOR USING OIL.</b> <b>THE OLD STYLE PUMP IS NO LONGER AVAILABLE, BUT PARTS ARE AVAILABLE SEPARATELY.</b> <b>WHEN ORDERING PARTS PLEASE SPECIFY OIL OR OIL-LESS.</b>
16	P-958	<u>BOLT</u> - FOR COMPRESSOR (NEED 4)
17	P-1850	<u>STEM</u> - FOR ELBOW, COMES WITH COMPRESSOR.
17A	P-1851	<u>ELBOW</u> - 90 DEGREE - (ITEM 17 COMES WITH COMPRESSOR ASSEMBLY)
18	P-1157	<u>COVER</u> - FOR BOTH PLASTIC & GLASS BOTTLE, #A ATTATCHES TO ITEM #6 OR #22, PAGE 4. #B ATTATCHES TO ITEM #6 OR #21, PAGE 4, & ITEM #23, PAGE 5
19	P-1147	<u>FILTER ASSEMBLY</u> - FOR BOTH OIL-LESS & OIL COMPRESSOR.
20	P-1146	<u>TUBE</u> - PLASTIC, FOR 2 FELT FILTERS P-1148, (STEEL STYLE NOT AVAILABLE)
21	P-1148	<u>FELT</u> - 2 FELTS PER FILTER (4 TOTAL)
22	P-1150	<u>CAP</u> - PLASTIC, TO HOLD 2 FELTS IN PLACE
23	P-1151	<u>GASKET</u> - FOR PLASTIC OR GLASS BOTTLE
24	P-1152	<u>FILTER BOTTLE</u> - PLASTIC ONLY. FOR BOTH OIL-LESS & OIL COMPRESSORS.
25	P-1149	<u>COVER</u> - OLD STYLE - STEEL, TO HOLD 2 FELTS IN PLACE, USING P-1186
26	P-1186	<u>BUTTON</u> - OLD STYLE SNAP MUST HAVE STEEL DISK P-1149
27	P-1165	<u>SEALER GASKET</u> - 2 INSIDE COMPRESSOR.
28	P-36033	<u>CAP</u>
29	P-1182	<u>COMPRESSOR REPAIR KIT</u> - FOR COMPRESSORS USING OIL. (NOT ILLUSTRATED) CONSISTS OF: 2 EA P-1151 - <u>GASKET</u> , FOR BOTTLES 4 EA P-1159 - <u>VANES</u> , INSIDE PUMP 2 EA P-1158 - <u>GASKETS</u> , LARGE; INSIDE PUMP 4 EA P-1148 - <u>FELT FILTERS</u> 1 EA P-1154 - <u>GASKET</u> , OIL BOTTLE 1 EA P-1155 - <u>WICK</u> , OIL BOTTLE 2 EA P-1166 - <u>OIL GASKET</u> , INSIDE PUMP 2 EA P-1165 - <u>SEAL</u> , INSIDE PUMP 1 EA P-1588 - <u>BOTTLE OF PUMP OIL</u>
29	P-30314	<u>COMPRESSOR REPAIR KIT</u> - FOR OIL-LESS PUMPS. (NOT ILLUSTRATED) CONSISTS OF THE FOLLOWING. 2 EA P-1151 - <u>GASKET</u> , FOR BOTTLES 4 EA P-5316 - <u>VANES</u> , INSIDE PUMP 2 EA P-1158 - <u>GASKETS</u> , LARGE; INSIDE PUMP 4 EA P-1148 - <u>FELT FILTERS</u>
30	P-1588	<u>OIL &amp; JAR</u> - JAR P-1156 & PROPER PUMP OIL
31	P-1587	<u>1/2 PINT OF PUMP OIL</u>
32	P-1586	<u>QUART OF PUMP OIL</u>
33	P-1500	<u>BOLT</u> - NEED 8
34	NO #	<u>REDUCER</u> - COMES WITH COMPRESSOR.
35	P-1975	<u>LOCKWASHER</u>
36	P-30312	<u>COOLING FAN</u> - FOR OIL-LESS COMPRESSOR ONLY.
37	P-711	<u>RETAINING RING</u>
38	P-10787	<u>RETAINING RING</u> - FOR OIL-LESS COMPRESSOR ONLY.
39	P-11821	<u>BELLEVILLE WASHER</u> - FOR OIL-LESS COMPRESSOR ONLY.
40	P-10981	<u>SHIM WASHER</u> - FOR OIL-LESS COMPRESSOR ONLY.
41	P-790	<u>BALL BEARING</u> - 2 INSIDE COMPRESSOR ONLY.
42	P-622	<u>WASHER</u>
43	P-5319	<u>ROTOR</u> - FOR OIL-LESS COMPRESSOR OMLY.
44	P-5316	<u>VANE</u> - FOR OIL-LESS COMPRESSOR ONLY. (NEED 4)
45	P-5118	<u>PULLEY</u> - FOR OIL-LESS COMPRESSOR ONLY.
		<b>NOTE:</b> 350, 360, 369, 375 & 9800 COMPRESSORS ARE THE SAME.

**DRAWING #4**  
**COMPRESSOR TUBING & CONNECTIONS - 350, 360, 375**

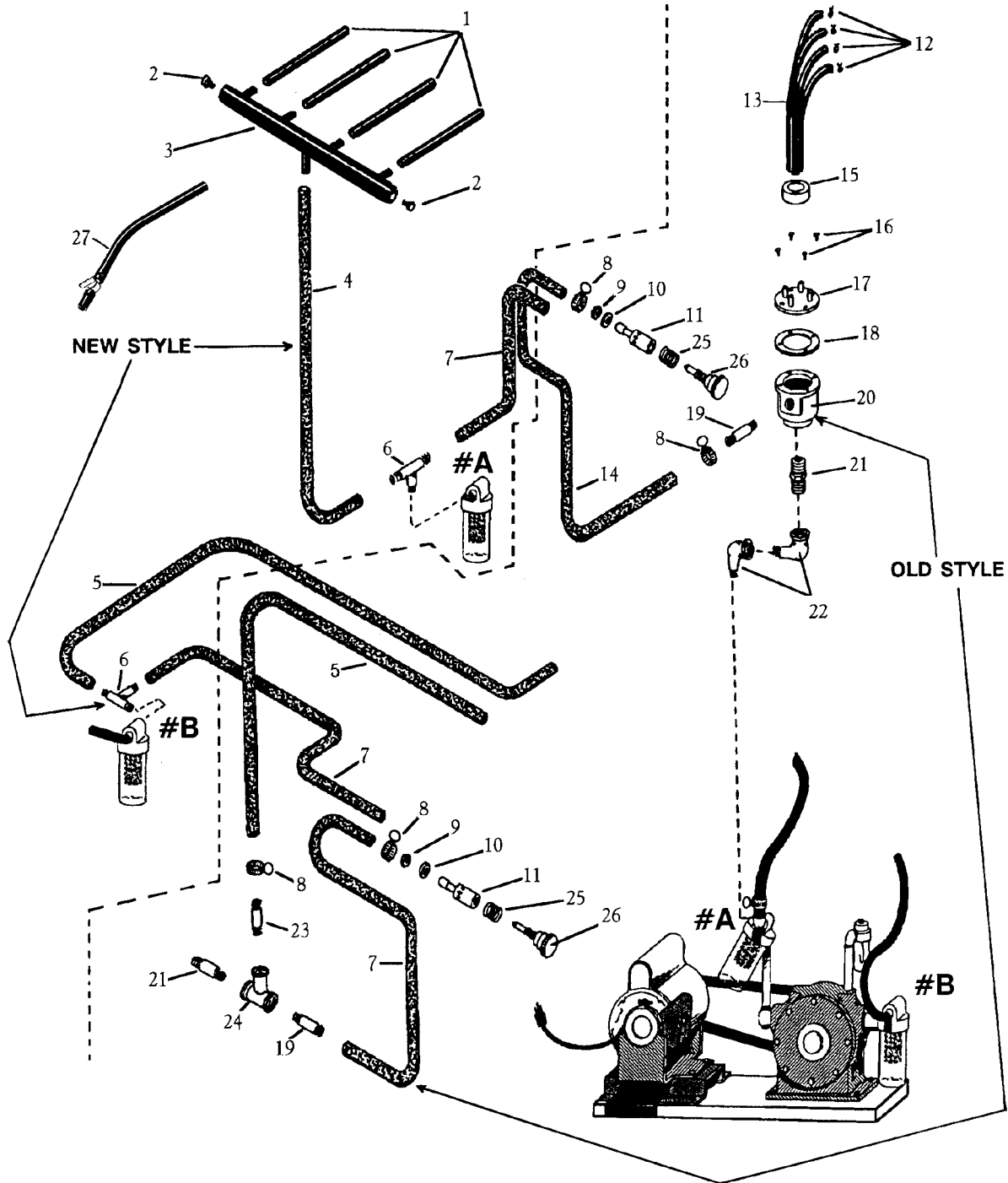

**PAGE #4**  
**COMPRESSOR TUBING & CONNECTIONS - 350, 360, 375**

KEY #	PART#	DESCRIPTION
1	P-1189	<u>TUBING</u> - TO PILE HEIGHT REGULATOR SEE ITEM #37, PAGE 10.
2	P-943	<u>HEX HEAD SCREW</u>
3	P-36064	<u>HEADER SHAFT</u> - ATTACHES TO BOTTOM OF THE LOWER SIDE FRAME.
	P-37064	<u>HEADER SHAFT</u> - ATTACHES TO BOTTOM OF THE LOWER SIDE FRAME.
4	P-1179	<u>TUBING</u>
5	P-1180	<u>TUBING</u> - TO MAKE OR BREAK CONTROL MECHANISM SEE ITEM #19, PAGE 5, FOR DIAGRAM B.
6	P-1086	<u>TEE</u>
7	P-1187	<u>TUBING</u> - TO BLEEDER VALVES, FOR DIAGRAM A.
8	P-1160	<u>HOSE CLAMP</u>
9	P-514	<u>NUT</u>
10	P-649	<u>WASHER</u>
11	P-36065	<u>BLEEDER VALVE</u> - ATTACHES TO TOP OF BASE FRAME ON OPERATORS SIDE. SEE ITEM #44, PAGE 48.
12	P-1177	<u>CLAMP</u> - HOSE
13	P-1181	<u>TUBING</u> - TO PILE HEIGHT REGULATOR SEE ITEM #37, PAGE 10.
14	P-1179	<u>TUBING</u> - FROM HEADER TO BLEEDER VALVE.
15	P-36399	<u>BAND</u>
16	P-76	<u>SCREW</u>
17	P-36068	<u>HEADER COVER</u>
18	P-1510	<u>GASKET-HEADER</u>
19	P-1172	<u>ADAPTER</u>
20	P-36069	<u>HEADER</u>
21	P-1163	<u>NIPPLE</u> - ATTACHES TO ITEM #18 (#A) DWG. 3.
22	P-1174	<u>ELBOW</u> - ATTACHES TO ITEM #18 (#8) DWG. 3.
23	P-1511	<u>NIPPLE</u>
24	P-1184	<u>TEE</u>
25	P-36173	<u>SPRING</u>
26	P-36074	<u>ADJUSTMENT SCREW</u> - FOR BLEEDER VALVE.
27	P-36760	<u>BLOWER TUBE SHUT OFF VALVE ASSEMBLY</u>
<p><b>NOTE:</b> SEE PAGE 4A FOR 369 &amp; 9800 HOSE AND VALVE SYSTEMS.</p>		

**DRAWING #4A**  
**COMPRESSOR TUBING & VALVE SYSTEM - 369, 9800**

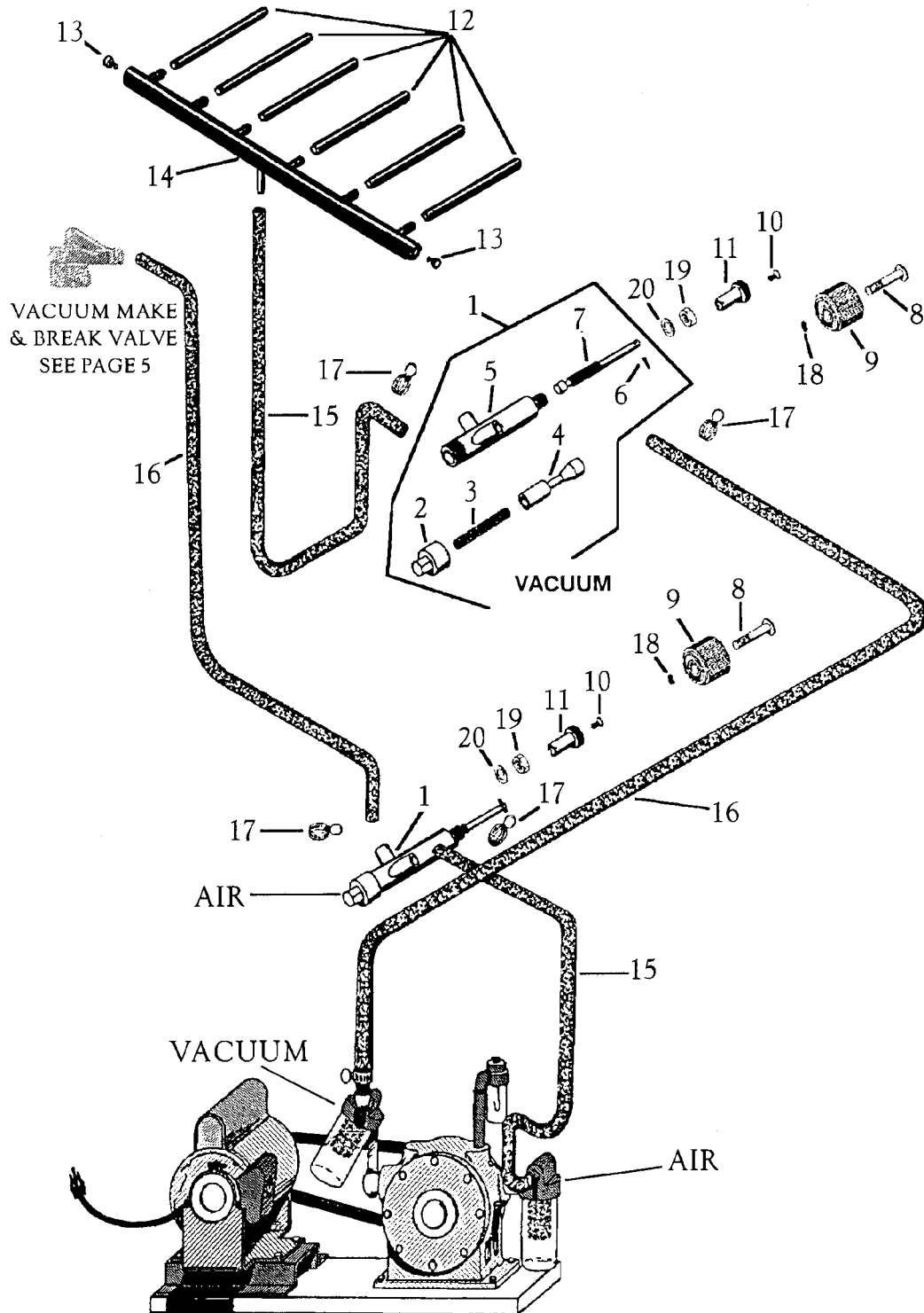

**PAGE #4A**  
**COMPRESSOR TUBING & VALVE SYSTEM - 369, 9800**

KEY #	PART#	DESCRIPTION
1	P-36847	<u>BLEEDER VALVE ASSEMBLY</u> - FOR 9800 & 369 (NEW STYLE). SEE ITEM #44, PAGE 48.
2	P-36951	<u>PLUG</u>
3	P-36859	<u>SPRING</u>
4	P-36845	<u>VALVE</u>
5	P-36844	<u>VALVE BODY</u> - (NEW STYLE) PLASTIC.
6	P-379	<u>ROLL PIN</u>
7	P-36841	<u>SHAFT</u>
8	P-8045	<u>SCREW</u> - FOR NEW STYLE BLEEDER VALVE 1/4-28 THREAD. (9800)
9	P-98031	<u>KNOB</u> - FOR NEW STYLE BLEEDER VALVE.
10	P-987	<u>SCREW</u> - FOR OLD STYLE BLEEDER VALVE. 8-32 THREAD. (369)
11	P-36063	<u>KNOB</u> - FOR OLD STYLE BLEEDER VALVE.
12	P-1189	<u>TUBING</u> - TO PILE HEIGHT REGULATOR SEE ITEM #37, PAGE 10.
13	P-943	<u>HEX HEAD SCREW</u>
14	P-36064	<u>HEADER SHAFT</u> - 350 & 360. ATTACHES TO BOTTOM OF THE LOWER SIDE FRAME.
	P-37064	<u>HEADER SHAFT</u> - 375 & 9800. ATTACHES TO BOTTOM OF THE LOWER SIDE FRAME.
15	P-1179	<u>TUBING</u>
16	P-1180	<u>TUBING</u>
17	P-1160	<u>HOSE CLAMP</u>
18	P-1495	<u>RETAINING RING</u>
19	P-1509	<u>NUT</u>
20	P-621	<u>WASHER</u>
		 <b>NOTE:</b> SEE PAGE 4 FOR 350, 360 & 375 TUBING AND VALVES.

**PAGE #5**  
**VACUUM MAKE & BREAK CONTROL MECHANISM**

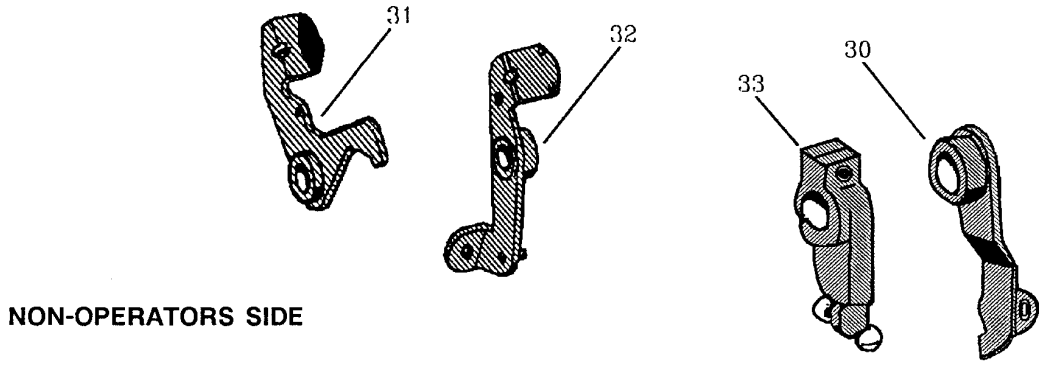

**NON-OPERATORS SIDE**

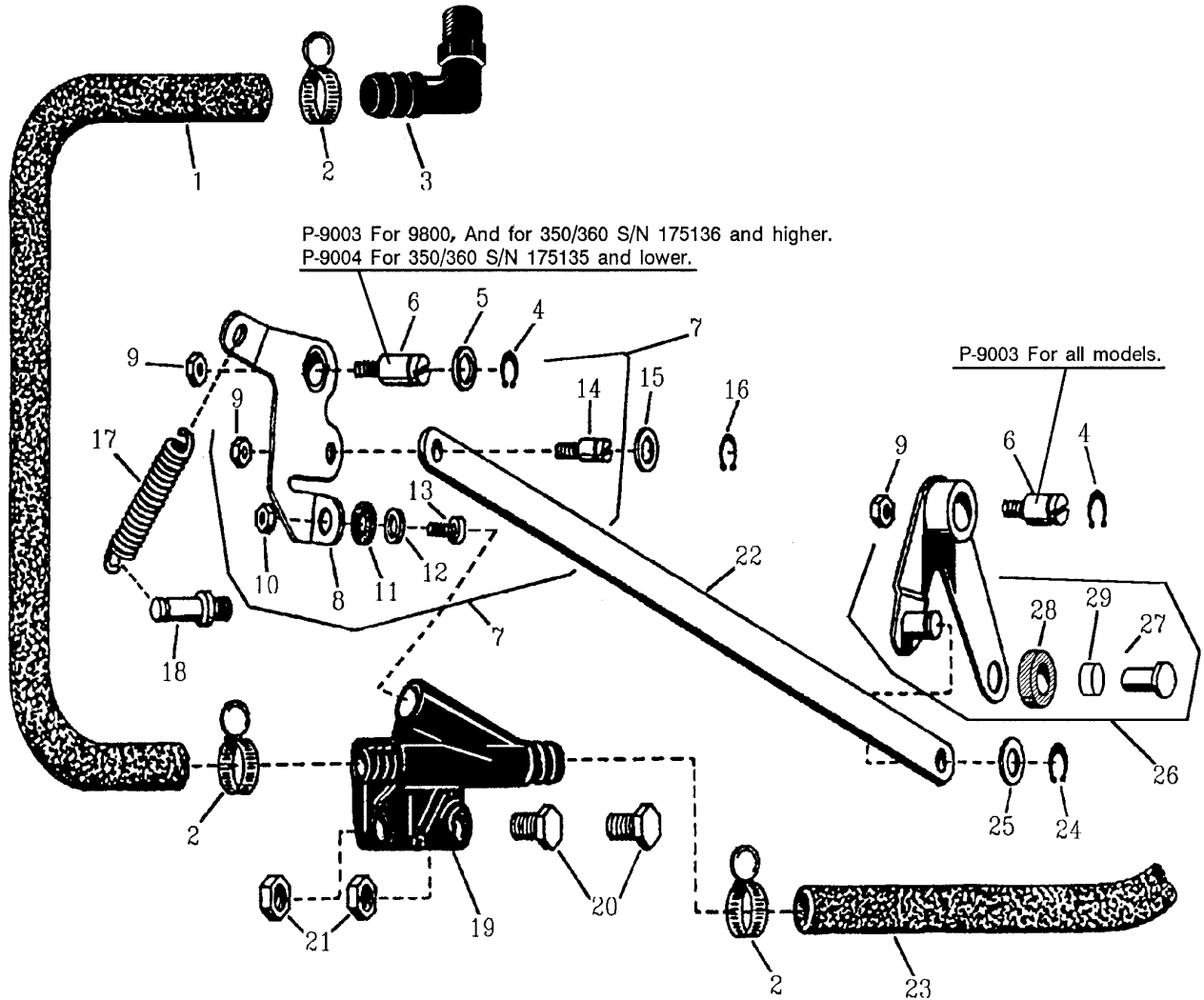

**PAGE #5**  
**VACUUM MAKE & BREAK CONTROL MECHANISM**

KEY #	PART#	DESCRIPTION
1	P-1188	<u>TUBING</u> - VACUUM
2	P-1160	<u>HOSE CLAMP</u>
3	P-1085	<u>ELBOW</u> - NEW STYLE - "PLASTIC" CONNECTS TO HEADER TUBE SHAFT, ITEM #2, PAGE 9. ON NON-OPER. SIDE OF FEEDER
	P-1515	<u>ELBOW</u> - OLD STYLE - "BRASS" CONNECTS TO HEADER TUBE SHAFT, ITEM #2, PAGE 9. ON NO-OPER. SIDE OF FEEDER
4	P-703	<u>RETAINING RING</u>
5	P-602	<u>WASHER</u>
6	P-9004	<u>RETAINING RING ANCHOR</u> - S/N #175135 & LOWER. 1 3/16" O.A.L.
	P-9003	<u>RETAINING RING ANCHOR</u> - S/N #175136 & HIGHER. 1" O.A.L. ALSO USED ON 9800.
7	P-36073	<u>LEVER ASSEMBLY</u> - VACUUM MAKE & BREAK LEVER. MOUNTS TO SIDE FRAME, ON NON-OPERATORS SIDE OF FEEDER.
8	P-36289	<u>LEVER</u> - (NOT SOLD SEPARATLY. SEE P-36073)
9	P-471	<u>KEPS NUT</u>
10	P-462	<u>KEPS NUT</u>
11	P-564	<u>LEATHER WASHER</u>
12	P-565	<u>WASHER</u>
13	P-245	<u>SCREW</u>
14	P-9002	<u>RETAINING RING ANCHOR</u>
15	P-598	<u>WASHER</u>
16	P-700	<u>RETAINING RING</u>
17	P-36032	<u>SPRING</u>
18	P-6010	<u>SPRING ANCHOR</u> - (FROM S/N #175136) SCREWS INTO SIDE FRAME FROM S/N #175136 & HIGHER.
19	P-36076	<u>MAKE &amp; BREAK VALVE</u> - NEW STYLE "PLASTIC".
20	P-8014	<u>SCREW</u> - OLD STYLE USED WITH "CASTING" MAKE AND BREAK VALVE (NOT SHOWN)
	P-8038	<u>SCREW</u> - NEW STYLE USED WITH "PLASTIC" MAKE AND BREAK VALVE
21	P-487	<u>FLANGED LOCK NUT</u> - NEW STYLE
	P-471	<u>KEPS NUT</u> - OLD STYLE
22	P-36077	<u>LINK</u>
23	P-1180	<u>TUBING</u> - SEE ITEM #5, PAGE 4, CONNECTS TO COMPRESSOR FILTER ASSEMBLY, ITEM #18, PAGE 3.
24	P-698	<u>RETAINING RING</u>
25	P-586	<u>WASHER</u>
26	P-36078	<u>CAM ROLLER LEVER ASSEMBLY</u> - MOUNTS TO OUTSIDE OF FRAME, BELOW IMPRESSION CYLINDER ARMS, SEE ITEM #17, PAGE 44.
27	P-1593	<u>RIVET</u>
28	P-1463	<u>CAM ROLLER</u>
29	P-1579	<u>SLEEVE</u>
30	OBSOLETE	<u>FEED LEVER</u> - USE NEW STYLE MAKE & BREAK CONTROL. (SEE NOTE) SEE ITEM #40, PAGE 9.
31	OBSOLETE	<u>LATCH</u> - USE NEW STYLE MAKE & BREAK CONTROL. (SEE NOTE)
32	OBSOLETE	<u>VACUUM LEVER</u> - USE NEW STYLE MAKE & BREAK CONTROL. (SEE NOTE)
33	OBSOLETE	<u>HEADER TUBE LEVER</u> - USE NEW STYLE MAKE & BREAK CONTROL. (SEE NOTE) SEE ITEM #39, PAGE 9.
<p><b>NOTE:</b> MAJOR REPAIRS MUST BE MADE TO CONVERT PRESS TO NEW STYLE, CALL A QUALIFIED REPAIRMAN TO INSTALL. RENOVATE</p>		

**DRAWING #6**  
**PAPER HEIGHT ADJUSTMENT MECHANISM**  
**(INSIDE FEEDER FRAME ON OPERATORS SIDE)**

**NEW DESIGN**

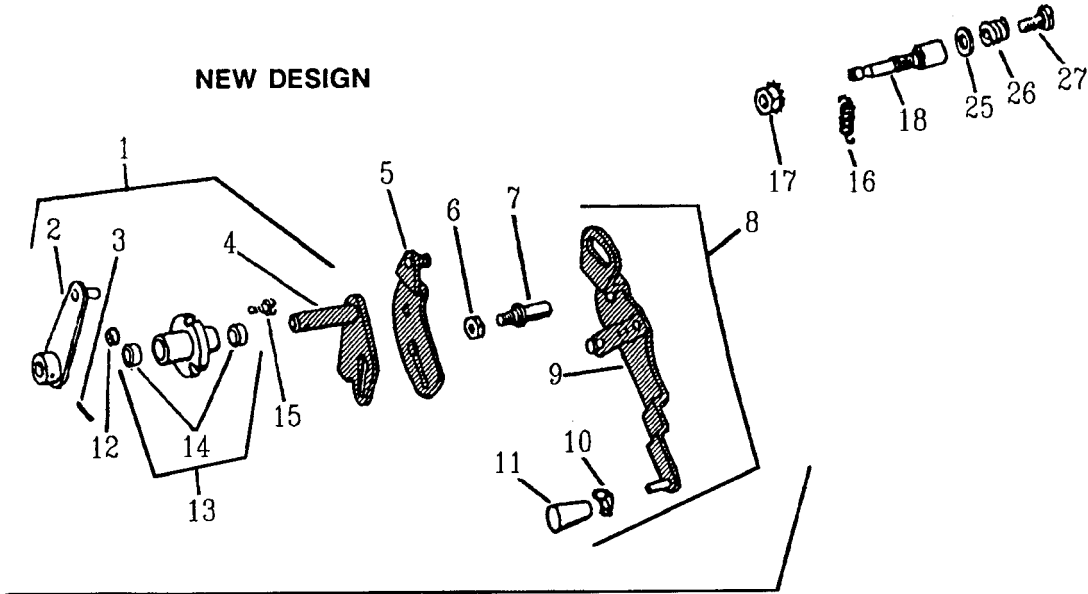

IF YOU HAVE OLD DESIGN YOU MUST  
 REPLACE COMPLETE UNIT.  
 ITEMS #28.

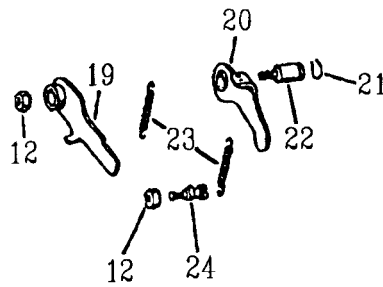

**OLD DESIGN**

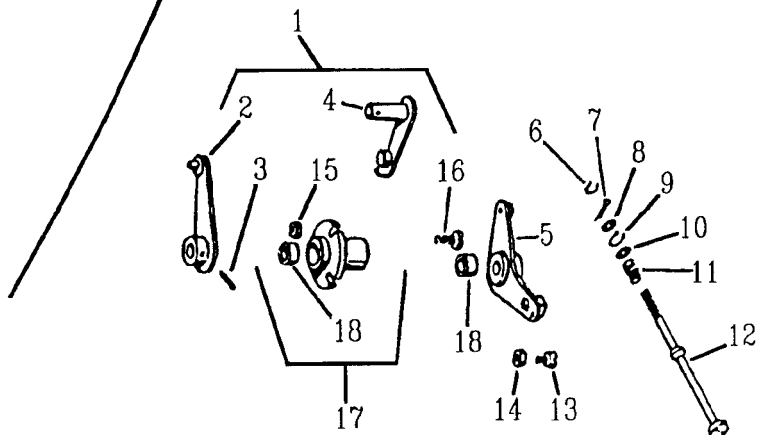



**PAGE #6**  
**PAPER HEIGHT ADJUSTMENT MECHANISM**

KEY #	PART#	DESCRIPTION
<b>NEW DESIGN</b>		
1	P-36782	<u>LEVER ASSEMBLY</u> - TABLE RAISING,LOCATED UNDERNEATH COUNTER ASSEMBLY.
2	NO #	<u>LEVER</u> - NOT SOLD SEPARATELY, SEE P-36782. CONNECTS TO LINK #11, PAGE 39.
3	P-350	<u>SPIRAL PIN</u>
4	NO #	<u>LEVER</u> - NOT SOLD SEPARATELY. SEE P-36782.
5	P-36788	<u>ADJUSTING LEVER ASSEMBLY</u> - CONNECTS TO LINK #30, PAGE 10, ON OUTSIDE OF SIDE FRAME
6	P-487	<u>NUT</u>
7	P-9015	<u>PIVOT PIN</u>
8	P-36794	<u>DWELL CONTROL LEVER ASSEMBLY</u>
9	P-36790	<u>DWELL CONTROL LEVER</u>
10	P-36410	<u>LOCK SPRING</u>
11	P-36062	<u>HANDLE</u>
12	P-471	<u>KEPS NUT</u> - 3 NEEDED
13	P-36796	<u>BEARING ASSEMBLY</u>
14	P-1203	<u>BUSHING</u>
15	P-261	<u>SCREW</u> - 3 NEEDED
16	P-36787	<u>SPRING</u> - SEE ITEM #18, THIS PAGE & ITEM #45, PAGE 39.
17	P-507	<u>KEPS NUT</u>
18	P-6035	<u>SPRING ANCHOR STUD</u>
19	P-36780	<u>LEVER ASSEMBLY</u>
20	P-36802	<u>CONTACT LEVER ASSEMBLY</u>
21	P-703	<u>RETAINING RING</u>
22	P-9017	<u>PIVOT STUD</u>
23	P-36798	<u>SPRING</u> - 2 NEEDED - 1 CONNECTS TO ITEM #20 & #24, THE OTHER CONNECTS TO #19 & #20, THIS PAGE.
	P-37798	<u>SPRING</u> - 2 NEEDED - 1 CONNECTS TO ITEM #20 & #24, THE OTHER CONNECTS TO #19 & #20, THIS PAGE.
24	P-6023	<u>SPRING ANCHOR</u>
25	P-613	<u>WASHER</u>
26	P-36786	<u>COMPRESSION SPRING</u>
27	P-36784	<u>SCREW</u>
28	P-36769	<u>PAPER HEIGHT ADJUSTMENT CONVERSION KIT</u> - TO CONVERT OLD STYLE TO NEW STYLE. CONSISTS OF ITEMS #1, 5, 6, 7, 8, 12, 13 & 15.
<b>OLD DESIGN</b>		
1	OBSOLETE	<u>LEVER ASSEMBLY</u> - TABLE RAISING,LOCATED UNDERNEATH COUNTER ASSEMBLY.
2	OBSOLETE	<u>TABLE RAISING LEVER</u> - CONNECTS TO LINK #11, PAGE 39.
3	P-350	<u>SPIRAL PIN</u>
4	OBSOLETE	<u>TABLE RAISING LEVER</u>
5	OBSOLETE	<u>LEVER ASSEMBLY</u> - CONNECTS TO LINK #30, PAGE 10.
6	P-698	<u>RETAINING RING</u>
7	P-339	<u>COTTER PIN</u>
8	P-577	<u>WASHER</u>
9	P-667	<u>RETAINING RING</u>
10	P-604	<u>WASHER</u>
11	P-36770	<u>COMPRESSION SPRING</u> - TO S/N 440714 & BELOW
	P-36707	<u>COMPRESSION SPRING</u> - FROM S/N 440715 & ABOVE
12	OBSOLETE	<u>PAPER HEIGHT SCREW</u>
13	P-36417	<u>ECCENTRIC SCREW</u>
14	P-487	<u>NUT</u>
15	P-471	<u>NUT</u> - 3 NEEDED
16	P-261	<u>SCREW</u> - 3 NEEDED
17	OBSOLETE	<u>BEARING ASSEMBLY</u>
18	P-1203	<u>BUSHING</u>
19	OBSOLETE	<u>LEVER ASSEMBLY</u>
20	P-36802	<u>CONTACT LEVER ASSEMBLY</u>
21	P-703	<u>RETAINING RING</u>
22	P-9017	<u>PIVOT STUD</u>
23	P-36798	<u>SPRING</u> - 2 NEEDED - 350, 360.
	P-37798	<u>SPRING</u> - 2 NEEDED - 375.
24	P-6023	<u>SPRING ANCHOR</u>
<b>NOTE:</b> IF YOU HAVE OLD DESIGN, YOU MUST REPLACE COMPLETE UNIT, #1, #5, #6, #7, #8, #12, #13, & #15.		

**DRAWING #7**  
**FEED TABLE & PAPER HEIGHT GUIDES - 350, 360, 375**

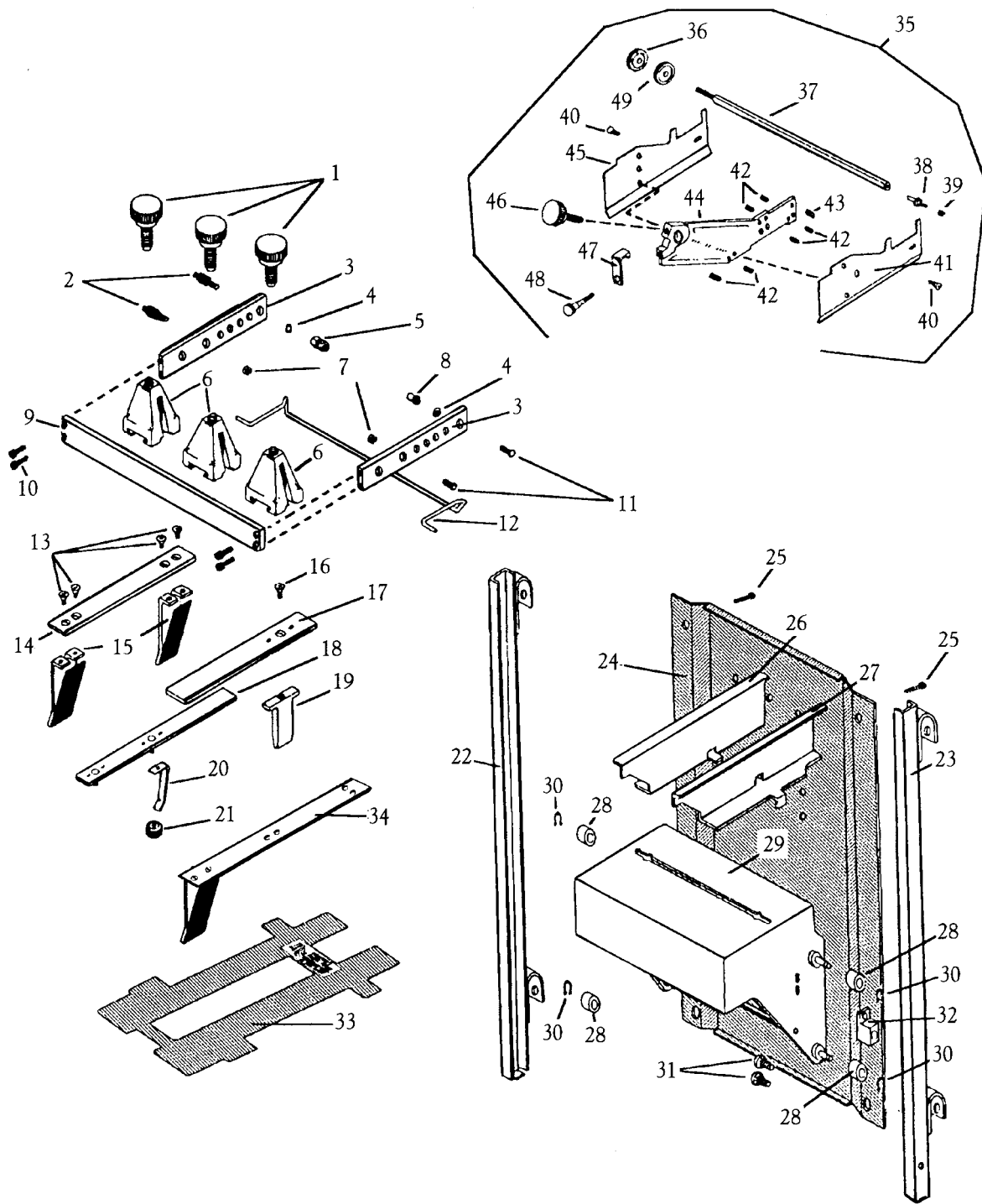

SEE PAGE 7A FOR 9800

**PAGE #7**  
**FEED TABLE & PAPER GUIDES - 350, 360, 375**

KEY #	PART#	DESCRIPTION
1	P-1539	<u>THUMB SCREW</u>
2	P-6009	<u>STUD</u> - ANCHOR FOR SPRING, ITEM #33, PAGE 9, & ITEM #24, PAGE 38.
3	P-36706	<u>SIDE MOUNTING BAR</u> - FIXED POSITION
4	P-635	<u>LOCK WASHER</u>
5	P-36711	<u>SPECIAL NUT</u>
6	P-36087	<u>ADJUSTING CLAMP</u>
7	P-487	<u>NUT</u>
8	P-36096	<u>SPECIAL NUT</u>
9	P-36713	<u>FRONT MOUNTING BAR</u> - 350 & 360 FIXED POSITION
	P-37713	<u>FRONT MOUNTING BAR</u> - 375 FIXED POSITION
10	P-43	<u>SCREW</u>
11	P-945	<u>SCREW</u>
12	P-36093	<u>PAPER WEIGHT</u> - 350 & 360 REGULAR WEIGHT FOR REGULAR STOCK
	P-36094	<u>PAPER WEIGHT</u> - 350 & 360 LIGHT WEIGHT FOR LIGHT WEIGHT STOCK
	P-37093	<u>PAPER WEIGHT</u> - 375 & 9800 REGULAR WEIGHT FOR REGULAR STOCK
	P-37094	<u>PAPER WEIGHT</u> - 375 & 9800 LIGHT WEIGHT FOR LIGHT WEIGHT STOCK
13	P-984	<u>SCREW</u>
14	P-36089	<u>SPRING GUIDE PLATE</u> - OPERATOR SIDE
15	P-36088	<u>SPRING GUIDE</u>
16	P-1000	<u>SCREW</u>
17	P-36092	<u>GUIDE PLATE</u> - NON OPERATOR SIDE
18	P-36712	<u>CENTER PLATE</u> - 350 & 360
	P-37712	<u>CENTER PLATE</u> - 375 & 9800
19	P-36100	<u>SIDE GUIDE</u>
20	P-36090	<u>BACK GUIDE</u>
21	P-1058	<u>THUMB NUT</u>
22	P-36098	<u>CHANNEL ASSEMBLY</u> - OPERATORS SIDE. 350, 360, 369, 375.
	P-98098	<u>CHANNEL ASSEMBLY</u> - OPERATORS SIDE. 9800.
23	P-36056	<u>CHANNEL ASSEMBLY</u> - NON-OPERATORS SIDE. 350, 360, 369, 375.
	P-98098	<u>CHANNEL ASSEMBLY</u> - NON-OPERATORS SIDE. 9800.
24	P-36086	<u>COVER PANEL</u> - 350 & 360 ATTACHES TO TIE BARS, ITEM #9, PAGE 49.
	P-37086	<u>COVER PANEL</u> - 375 ATTACHES TO TIE BARS, ITEM #9, PAGE 49.
	P-98162	<u>COVER PANEL &amp; MOTOR MOUNT</u> - 9800
25	P-943	<u>HEX HEAD SCREW</u>
26	P-36152	<u>GUIDE</u> - OPERATOR SIDE
27	P-36081	<u>SUPPORT GUIDE</u> - NON OPERATOR SIDE
28	P-1458	<u>TRUCK</u>
29	P-36301	<u>FEED TABLE ASSEMBLY</u>
30	P-669	<u>C-RING</u>
31	P-256	<u>SCREW</u>
32	P-36083	<u>TRIP BRACKET</u>
33	P-36964	<u>PAPER SUPPORT TRAY</u> - STEEL, RESTS ON PAPER SUPPORTS.
34	P-38091	<u>SPRING GUIDE ASSEMBLY</u> - OPERATORS SIDE (385 ONLY) CONSISTS OF ITEMS #14 8#15.
35	P-36113	<u>MICRO ADJUSTING GUIDE KIT</u>
36	P-36811	<u>ADJUSTING THUMB NUT</u> - FACE HUBS TOGETHER WHEN INSTALLING.
36	P-36811	<u>ADJUSTING THUMB NUT</u> - FACE HUBS TOGETHER WHEN INSTALLING.
37	P-36222	<u>SHAFT</u>
38	P-7011	<u>STUD</u>
39	P-487	<u>NUT</u>
40	P-1009	<u>SCREW</u>
41	P-36220	<u>GUIDE</u> - NON-OPERATORS SIDE.
42	P-1488	<u>SET SCREW</u> - LOCKING.
43	P-399	<u>ROLL PIN</u>
44	P-36221	<u>MOUNT</u>
45	P-36218	<u>GUIDE</u> - OPERATORS SIDE.
46	P-1539	<u>THUMB SCREW</u>
47	P-36067	<u>RETAINER PLATE</u>
48	P-8044	<u>THUMB SCREW</u>
49	P-1489	<u>ADJUSTING THUMB NUT</u> - FACE HUBS TOGETHER WHEN INSTALLING.

**DRAWING #7A**  
**PAPER GUIDES & SUPPORT BAR - 9800**

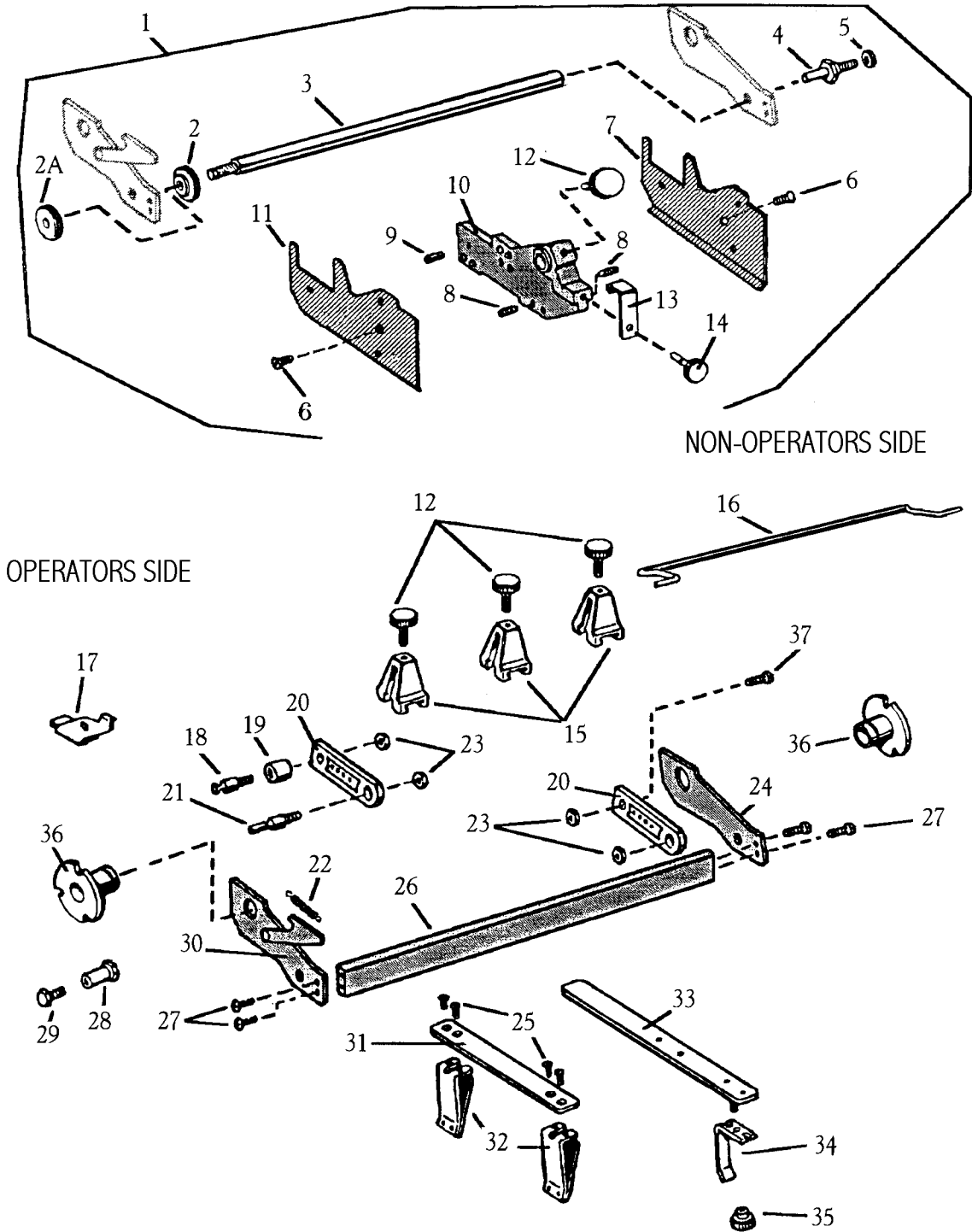

SEE PAGE 7 FOR 350, 360, & 375

**PAGE #7A**  
**PAPER GUIDES & SUPPORT BAR - 9800**

KEY #	PART#	DESCRIPTION
1	P-37113	<u>MICRO ADJUSTING GUIDE KIT</u>
2	P-98811	<u>ADJUSTING THUMB NUT</u> - FACE HUBS TOGETHER WHEN INSTALLING.
2A	P-36811	<u>ADJUSTING THUMB NUT</u> - FACE HUBS TOGETHER WHEN INSTALLING.
3	P-37222	<u>SHAFT</u> - 375 & 9800.
4	P-7011	<u>STUD</u>
5	P-487	<u>NUT</u>
6	P-1009	<u>SCREW</u>
7	P-36220	<u>GUIDE</u> - OPERATORS SIDE.
8	P-1488	<u>SET SCREW</u> - LOCKING.
9	P-399	<u>ROLL PIN</u>
10	P-36221	<u>MOUNT</u>
11	P-36218	<u>GUIDE</u> - NON-OPERATORS SIDE.
12	P-1539	<u>THUMB SCREW</u>
13	P-36067	<u>RETAINER PLATE</u>
14	P-8044	<u>THUMB SCREW</u>
15	P-36087	<u>ADJUSTING CLAMP</u>
16	P-37093	<u>PAPER WEIGHT</u> - REGULAR WEIGHT FOR REGULAR STOCK.
	P-37094	<u>PAPER WEIGHT</u> - LIGHT WEIGHT FOR LIGHT WEIGHT STOCK.
17	P-36223	<u>STOP BRACKET</u>
18	P-6009	<u>STUD</u> - ANCHOR FOR SPRING, ITEM #33, PAGE 9 & ITEM #24, PAGE 38.
19	P-1538	<u>SPACER</u>
20	P-98067	<u>PLATE</u>
21	P-6044	<u>SPRING ANCHOR</u> - FOR MODELS 9805 - 9810.
	P-6045	<u>SPRING ANCHOR</u> - FOR MODELS 9815 - 9850.
22	P-98711	<u>SPRING</u>
23	P-487	<u>NUT</u>
24	P-98706	<u>SIDE PLATE</u> - RESTS ON ITEM #20, THIS PAGE.
25	P-984	<u>SCREW</u>
26	P-98713	<u>MOUNTING BAR</u>
27	P-82	<u>SCREW</u>
28	P-1726	<u>ADAPTER NUT</u>
29	P-92	<u>SCREW</u>
30	P-98152	<u>SIDE PLATE &amp; LATCH</u> - LATCHES ONTO ITEM #28, THIS PAGE IN UP POSITION. RESTS ON ITEM #20, THIS PAGE IN DOWN POSITION.
31	P-36089	<u>SPRING GUIDE PLATE</u> - OPERATORS SIDE.
32	P-36088	<u>SPRING GUIDE</u>
33	P-37712	<u>CENTER PLATE</u>
34	P-36090	<u>BACK GUIDE</u>
35	P-1058	<u>NUT</u>
36	P-36167	<u>HOUSING</u> - SUPPORTS PLATES #24 & #30 THIS PAGE. (SEE PAGE 9 ITEM #17)
37	P-945	<u>SCREW</u>

**DRAWING #8**  
**FEED TABLE RAISING & ADJUSTING MECHANISM**

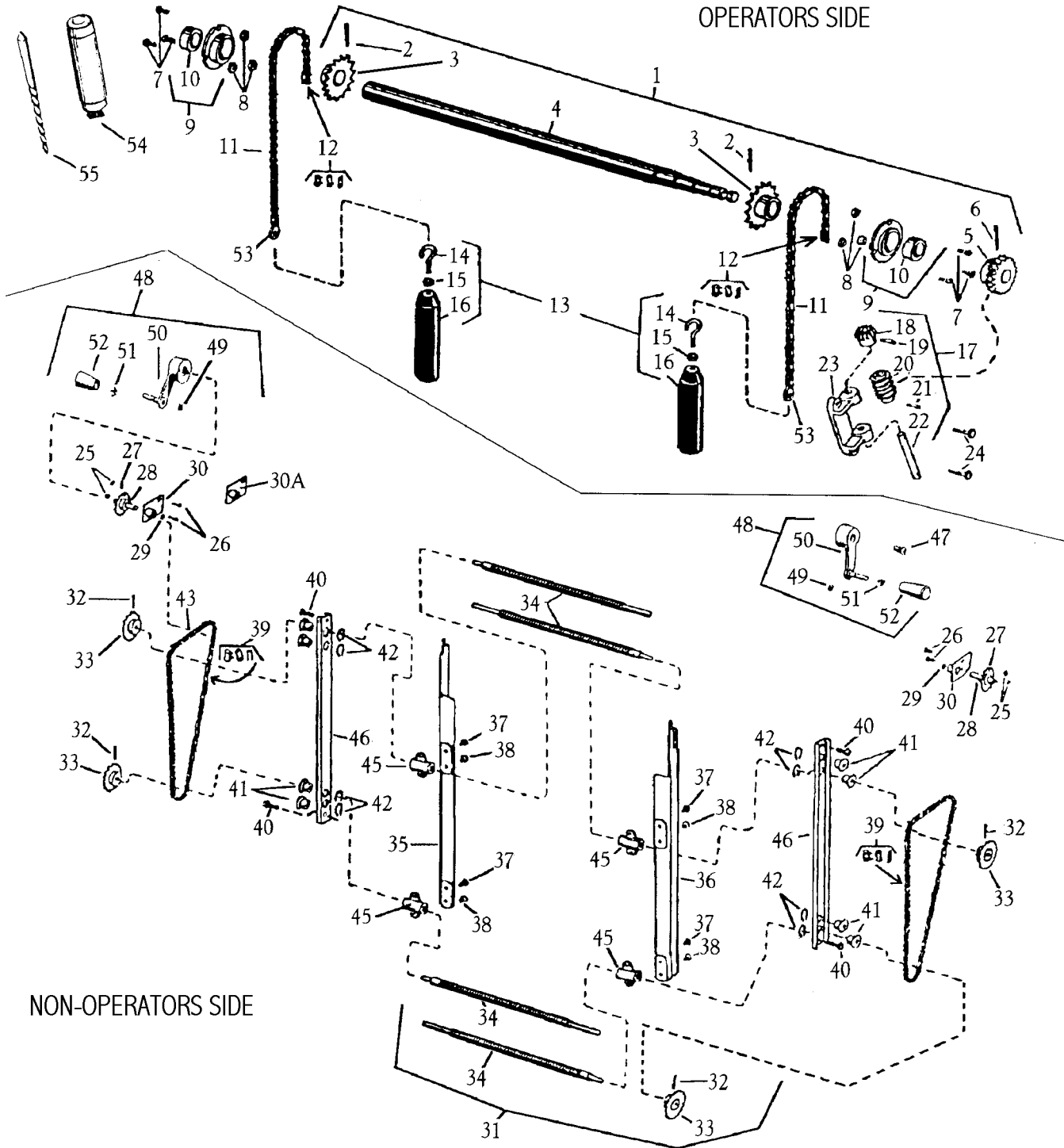

**PAGE #8**  
**FEED TABLE RAISING & ADJUSTING MECHANISM**

KEY #	PART#	DESCRIPTION
1	P-36070	<u>TABLE RAISING SHAFT ASSEMBLY</u> - MOUNTS THROUGH SIDE FRAME BELOW MAIN TIE BAR (FEEDER) ITEM #29, PAGE 10.
	P-37070	<u>TABLE RAISING SHAFT ASSEMBLY</u> - MOUNTS THROUGH SIDE FRAME BELOW MAIN TIE BAR (FEEDER) ITEM #29, PAGE 10.
	P-98070	<u>TABLE RAISING SHAFT ASSEMBLY</u> - MOUNTS THROUGH SIDE FRAME BELOW MAIN TIE BAR (FEEDER) ITEM #29, PAGE 10.
2	P-444	<u>TAPER PIN</u> - FOR P-36101
3	P-36101	<u>SPROCKET</u> - PILOT HOLE DRILLED ONLY - MUST HAVE PROPER TOOLS TO INSTALL (HAND REAMER TOOL P-1546 & REAMER BIT P-5961) OR USE P-36070,P-37070 or P-98070.
4	P-36102	<u>TABLE RAISING SHAFT</u> - SEE ITEMS #25, #9, & #36, PAGE 39.
	P-37102	<u>TABLE RAISING SHAFT</u> - SEE ITEMS #25, #9, & #36, PAGE 39.
	P-98102	<u>TABLE RAISING SHAFT</u> - SEE ITEMS #25, #9, & #36, PAGE 39.
5	P-36103	<u>GEAR</u> - SHOULD BUY WORM P-36110 WHEN REPLACING THIS GEAR - ITEM #20, THIS PAGE.
	P-38103	<u>GEAR</u> - SHOULD BUY WORM P-36014 WHEN REPLACING THIS GEAR - ITEM #20, THIS PAGE.
6	P-356	<u>SPIRAL PIN</u> - FOR P-36103
7	P-82	<u>HEX HEAD SCREW</u>
8	P-471	<u>KEPS NUT</u> - FOR P-82
9	P-36104	<u>BEARING ASSEMBLY</u>
10	P-1304	<u>BUSHING</u> - FOR OLD STYLE BEARING P-36104 ONLY, NEW STYLE NEEDS NO BUSHING.
11	P-36105	<u>CHAIN</u> - INCLUDES P-36970 WEIGHT HOLDER
12	P-1540	<u>MASTER LINK</u> - FOR P-36105
13	P-36106	<u>FEED TABLE WEIGHT ASSEMBLY</u>
14	P-1038	<u>WEIGHT HOOK</u>
15	P-473	<u>NUT</u>
16	P-36107	<u>FEED TABLE WEIGHT</u>
17	P-36108	<u>MITER &amp; WORM GEAR ASSEMBLY</u> - OPERATORS SIDE - NO BRACKET.
	P-37108	<u>MITER &amp; WORM GEAR ASSEMBLY</u> - OPERATORS SIDE - NO BRACKET.
	P-37039	<u>MITER &amp; WORM BRACKET ASSEMBLY</u> - AVAILABLE WITH BRACKET.
18	P-36109	<u>GEAR</u> - RUNS WITH ITEM #18, PAGE 39.
19	P-383	<u>ROLL PIN</u>
	P-360	<u>ROLL PIN</u> - 375 & 9800 ONLY
20	P-36110	<u>WORM</u> - 350, 360. SHOULD BUY GEAR P-36103 WHEN REPLACING THIS WORM - SEE ITEM #5, THIS PAGE.
	P-36014	<u>WORM</u> - 375, 385, 9800, SHOULD BUY GEAR P-38103 WHEN REPLACING THIS WORM - SEE ITEM #5, THIS PAGE.
21	P-431	<u>TAPER PIN</u>
22	P-36111	<u>SHAFT</u> - 350 & 360.
	P-37111	<u>SHAFT</u> - 375 & 9800.
23	P-36112	<u>MITER &amp; WORM BRACKET</u> - ATTACHES TO LOWER SIDE FRAME, OPERATORS SIDE.
	P-37112	<u>MITER &amp; WORM BRACKET</u> - ATTACHES TO LOWER SIDE FRAME, OPERATORS SIDE. INCLUDED WITH GEAR ASSEMBLY P-37039.
24	P-8036	<u>SHOULDER SCREW</u>
25	P-487	<u>NUT</u>
26	P-275	<u>SCREW</u>
27	P-380	<u>ROLL PIN</u>
28	P-36114	<u>SPROCKET</u> - ATTACHES TO BRACKET, ITEM #30, THIS PAGE.
	P-98114	<u>SPROCKET</u> - ATTACHES TO BRACKET, ITEM #30, THIS PAGE.
29	P-705	<u>RETAINING RING</u> - FOR P-36114
30	P-36115	<u>BRACKET</u> - ATTACHES TO TOP CORNER OF BASE FRAME, BY FEEDER.
	P-98115	<u>BRACKET</u> - ATTACHES TO TOP CORNER OF BASE FRAME, BY FEEDER.
30A	P-98119	<u>BRACKET</u> - ATTACHES TO TOP CORNER OF BASE FRAME, BY FEEDER, OPERATORS SIDE.
31	P-36116	<u>TABLE GUIDE SCREW ASSEMBLY</u>
	P-37116	<u>TABLE GUIDE SCREW ASSEMBLY</u>
32	P-443	(1) <u>TAPER PIN</u> - FOR P-36117 or P-37117
33	P-36117	(1) <u>SPROCKET</u>
34	P-36118	(1) <u>SCREW</u> - (SHAFT)
	NO #	<u>SCREW</u> - FOR 375 & 9800 IS NOT SOLD SEPARATELY.
35	P-36119	<u>ADJUSTING MECHANISM GUIDE</u> - NON-OPERATORS SIDE. MOUNTS TO FRONT OF BASE FRAME.
	P-36120	<u>ADJUSTING MECHANISM GUIDE</u> - NON-OPERATORS SIDE. FOR MODELS WITH MICRO LATERAL ADJUSTMENT
36	P-36121	<u>ADJUSTING MECHANISM GUIDE</u> - OPERATORS SIDE. MOUNTS TO FRONT OF BASE FRAME.
37	P-8028	<u>TOP SCREW</u> - WITH SHOULDER
38	P-11644	<u>SCREW</u> - NO SHOULDER
39	P-1540	<u>MASTER LINK</u> - 1 PER CHAIN
40	P-957	<u>SCREW</u>
41	P-1544	<u>BEARING</u>
42	P-711	<u>RETAINING RING</u>
43	P-36122	<u>CHAIN</u> - NON-OPERATORS SIDE. 89 PITCHES, INCLUDES ITEM 39,THIS PAGE
44	P-36123	<u>CHAIN</u> - OPERATORS SIDE. 91 PITCHES, INCLUDES ITEM 39,THIS PAGE
45	P-36124	<u>ADJUSTING BEARING</u>
46	P-36125	<u>BRACKET</u> - MOUNTS ON SIDE OF BASE FRAME, HOLDING SPROCKET & CHAIN.
47	P-299	<u>SCREW</u>
48	P-36060	<u>CRANK ASSEMBLY</u> - ATTACHES TO SPROCKET, ITEM #28, THIS PAGE. SEE ITEM #58 PAGE 47 & ITEM #36 PAGE 39.
	P-98060	<u>CRANK ASSEMBLY</u> - 9800 ONLY. ATTACHES TO SPROCKET, ITEM #28, THIS PAGE. SEE ITEM #36 PAGE 39 & #27 PAGE 47A.
49	P-10	<u>SCREW</u>
50	P-36061	<u>CRANK &amp; STUD</u>
51	P-36410	<u>LOCK SPRING</u>
52	P-36062	<u>HANDLE</u>
53	P-36970	<u>WEIGHT HOLDER</u>
54	P-1546	<u>HAND REAMER TOOL</u>
55	P-5961	<u>REAMER</u>

DRAWING #9  
SUCKER FOOT MECHANISM & PAPER FEED SHAFT ASSEMBLY

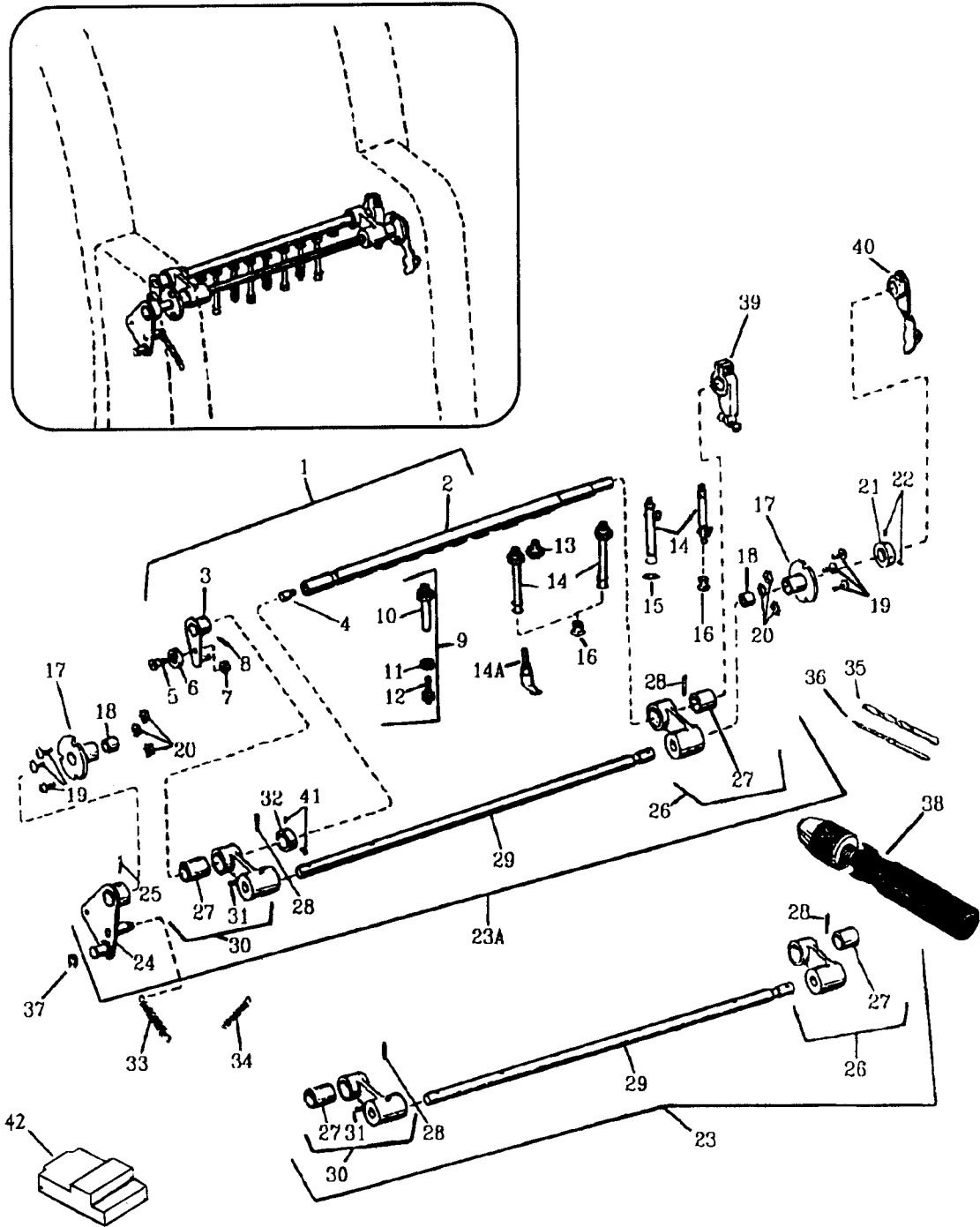



**PAGE #9**  
**SUCKER FOOT MECHANISM & PAPER FEED ASSEMBLY**

KEY #	PART#	DESCRIPTION
1	P-36126	<u>HEADER TUBE SHAFT ASSEMBLY</u> - (USES NEW STYLE ELBOW, SEE #3, PAGE 5, P-1085), OPERATED BY #19, PAGE 44.
	P-37126	<u>HEADER TUBE SHAFT ASSEMBLY</u> - (USES NEW STYLE ELBOW, SEE ITEM #3, PAGE 5, P-1085), OPERATED BY ITEM #19, PAGE 44.
2	P-36127	<u>HEADER TUBE SHAFT</u> - NOT SOLD SEPARATELY (USES NEW STYLE ELBOW, SEE ITEM #3, PAGE 5. P-1085)
	P-37127	<u>HEADER TUBE SHAFT</u> - NOT SOLD SEPARATELY (USES NEW STYLE ELBOW, SEE ITEM #3, PAGE 5. P-1085)
3	P-36128	<u>LEVER</u> - NOT SOLD SEPARATELY
4	P-1545	<u>PLUG</u>
5	P-8029	<u>SHOULDER SCREW</u>
6	P-1464	<u>CAM</u> - OPERATES ON LEVER, ITEM #21, PAGE 38.
7	P-487	<u>NUT</u>
8	P-436	<u>TAPER PIN</u>
9	P-36164	<u>PAPER LEVELER ASSEMBLY</u>
10	P-36166	<u>PAPER LEVELER TUBE</u>
11	P-36168	<u>NUT</u>
12	P-36170	<u>PLUG ADJUSTMENT</u>
13	P-36172	<u>PLUG</u>
14	P-36174	<u>SUCKER TUBE</u> - WITHOUT VALVES
	P-36990	<u>SUCKER TUBE</u> - WITH SHUT OFF VALVES
	P-36966	<u>COMPENSATING SUCKER TUBES</u> - WITH SHUT OFF VALVES, GOOD FOR ENVELOPES
14A	P-98990	<u>SUCKER TUBE</u> - 9800 ONLY - INSERT
15	P-1552	<u>SUCTION FOOT</u> - STANDARD (3/4" DIA.) FLAT (OLD STYLE, FITS P-36996)
	P-1554	<u>SUCTION FOOT</u> - (1/2" DIA.) FLAT (OLD STYLE)
16	P-1555	<u>SUCKER FOOT</u> - (CUP) NEW STYLE STANDARD FITS P-36174 & P-36990
17	P-36176	<u>HOUSING ASSEMBLY</u> - NO BUSHING NEW STYLE FOR FIXED GUIDE BAR
	P-36167	<u>HOUSING ASSEMBLY</u> - FOR SWING GUIDE BAR (NOT SHOWN)
18	P-1223	<u>BUSHING</u> - ONLY ON OLD STYLE OR SWING GUIDE BAR
19	P-82	<u>HEX HEAD SCREW</u>
20	P-472	<u>KEPS NUT</u>
21	P-743	<u>COLLAR</u>
22	P-18	<u>SET SCREW</u>
23A	P-36129	<u>SHAFT ASSEMBLY</u> - FEED RAISE, OPERATED BY ITEM #24, THIS PAGE.
	P-37129	<u>SHAFT ASSEMBLY</u> - FEED RAISE, OPERATED BY ITEM #24, THIS PAGE.
23	P-36169	<u>SUB SHAFT ASSEMBLY</u> - FEED RAISE, INCLUDES ITEMS #26, #28, #29, #30, THIS PAGE.
	P-37169	<u>SUB SHAFT ASSEMBLY</u> - FEED RAISE, INCLUDES ITEMS #26, #28, #29, #30, THIS PAGE.
24	P-36130	<u>LEVER</u> - CONNECTS TO LEVER #18, PAGE 38. ONLY ONE HOLE DRILLED TO START TAPER PIN OR USE ITEM #23A - P-36129 / USE ITEM #35 - P-1589 & ITEM #36 - P-1590 THIS PAGE.
25	P-392	<u>ROLL PIN</u>
	P-429	<u>TAPER PIN</u> - (OLD STYLE ONLY)
26	**P-36132	<u>LEVER ASSEMBLY</u> - NON-OPERATOR SIDE, ONLY ONE HOLE DRILLED TO START TAPER PIN / USE ITEM #23 - P-36169 / USE ITEM #35 - P-1589, & ITEM #36 - P-1590 THIS PAGE.
27	P-1268	<u>BUSHING</u>
28	P-433	<u>TAPER PIN</u>
29	P-36133	<u>SHAFT</u>
	P-37133	<u>SHAFT</u>
30	**P-36131	<u>LEVER ASSEMBLY</u> - OPERATORS SIDE. ONLY ONE HOLE DRILLED TO START TAPER PIN. USE ITEM #23 - P-36169 / USE ITEM #35 - P-1589 & ITEM #36 - P-1590 THIS PAGE.
31	P-6011	<u>SPRING ANCHOR</u> - FOR LEVER ITEM #30, THIS PAGE
32	P-749	<u>COLLAR</u>
33	P-36219	<u>SPRING</u> - CONNECTS TO STUD ITEM #2, PAGE 7 FOR 350 & 360 & ITEM #18, PAGE 7A FOR 375 & 9800.
34	P-36032	<u>SPRING</u> - CONNECTS TO LEVERS ITEMS #3 & #30. THIS PAGE
35	P-1589	<u>DRILL BIT</u> - FOR P-433 TAPER PIN
36	P-1590	<u>REAMER</u> - FOR P-433 TAPER PIN
37	P-703	<u>C-RING</u>
38	P-1546	<u>HAND REAMER</u> - TOOL
39	OBSOLETE	<u>LEVER ASSEMBLY</u> - USE NEW STYLE MAKE & BREAK CONTROL. MAJOR REPAIRS MUST BE MADE TO CONVERT PRESS TO NEW STYLE. CALL A QUALIFIED REPAIRMAN TO INSTALL. SEE ITEMS #4, #18, #22, #24 & #26, PAGE 5.
40	OBSOLETE	<u>LEVER</u> - USE NEW STYLE MAKE & BREAK CONTROL. MAJOR REPAIRS MUST BE MADE TO CONVERT PRESS TO NEW STYLE. CALL A QUALIFIED REPAIRMAN TO INSTALL. SEE ITEMS #4, #18, #22, #24, #26, PAGE 5.
41	P-8	<u>SET SCREW</u>
42	P-5027	<u>GUAGE</u> - SUCKER FOOT HEIGHT ADJUSTMENT. ** DUE TO THE PRECISION REQUIRED WHEN REPLACING THIS LEVER ASSEMBLY, A STARTER HOLE HAS BEEN DRILLED. DRILL BIT ITEM #35 - P-1589 & TAPERED REAMER ITEM #36 - P-1590 THIS PAGE SHOULD BE USED FOR PROPER INSTALLATION.

**DRAWING #10**  
**MAIN TIE BAR ASSEMBLY**

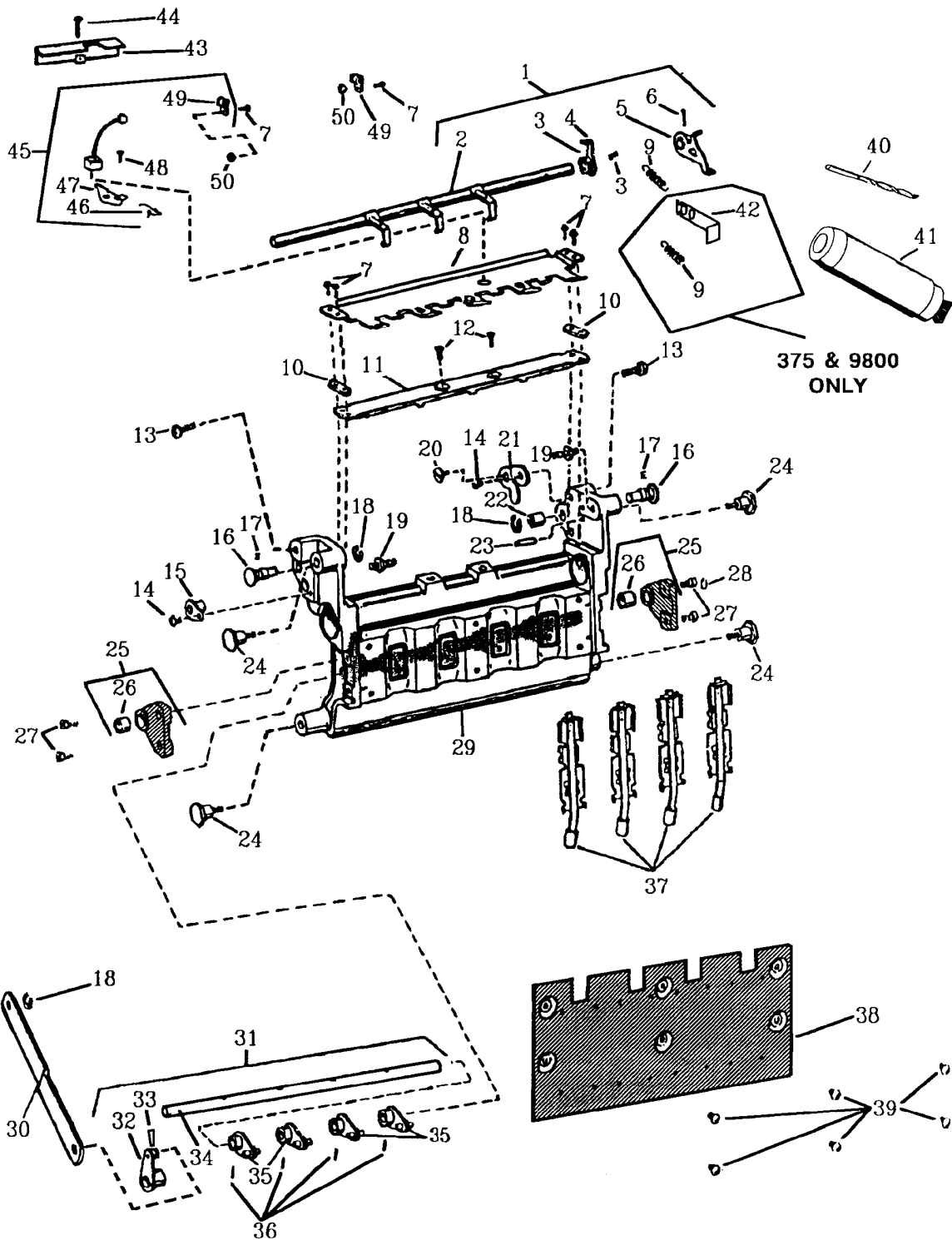

**PAGE #10  
MAIN TIE BAR ASSEMBLY**

KEY #	PART#	DESCRIPTION
1	P-36138 P-37138	<u>PAPER FEELER SHAFT ASSEMBLY</u> - WITH SET SCREW & ROLL PIN (NEW STYLE) - 350, 360 & 369. <u>PAPER FEELER SHAFT ASSEMBLY</u> - WITH SET SCREW & ROLL PIN (NEWS TLYE) - 375, 9805 & 9810. SEE ITEM #45 FOR 9815 - 9850
2	P-36139 P-37139	<u>PAPER FEELER SHAFT</u> - 350, 360 & 369. <u>PAPER FEELER SHAFT</u> - 375, 9805 & 9810.
3	P-421 P-7	<u>TAPER PIN</u> - OLD STYLE. <u>SET SCREW</u> - NEW STYLE.
4	P-36141	<u>LEVER</u>
5	P-36140	<u>LEVER</u> - HAS PILOT HOLE ONLY. MUST DRILL (SEE ITEM #40) OR USE ITEM #1, THIS PAGE P-36138 OR P-37138.
6	P-422 P-380	<u>TAPER PIN</u> - OLD STYLE. <u>ROLL PIN</u> - NEWS TYLE.
7	P-1052	<u>SCREW</u>
8	OBSOLETE P-36143 P-37142 P-98142	<u>UPPER PAPER CHUTE</u> - (S/N #671727 & BELOW) BOTH ENDS ARE ANGLED. (USE P-36625 ITEM #10A). <u>UPPER PAPER CHUTE</u> - (S/N #671728 & ABOVE) ENDS ARE COMPLETELY STRAIGHT. USE WITH ITEM #11 P-36145. <u>UPPER PAPER CHUTE</u> - 375, 9805 & 9810. <u>UPPER PAPER CHUTE</u> - 9815 - 9850.
9	P-36798 P-37798	<u>SPRING</u> - OTHER END TO ITEM #23 THIS PAGE. <u>SPRING</u> - OTHER END TO ITEM #23 THIS PAGE.
10	P-1580	<u>SPACER</u> - USED WITH ITEM #8 P-36143 & ITEM #11 P-36145 THIS PAGE.
10A	P-36625	<u>UPPER PAPER CHUTE ASSEMBLY</u> - FOR S/N #671727 & BELOW.
11	OBSOLETE P-36145  P-37144 P-98144	<u>LOWER PAPER CHUTE</u> - 350, 360 & 369. (S/N #671727 & BELOW) BOTH ENDS ARE ANGLED. (USE P-36625 ITEM #10A). <u>LOWER PAPER CHUTE</u> - 350, 360 & 369 (S/N #671728 & ABOVE) ENDS ARE COMPLETELY STRAIGHT. USE WITH ITEM #8 P-36143. <u>LOWER PAPER CHUTE</u> - 375, 9805 & 9810. <u>LOWER PAPER CHUTE</u> - 9815 - 9850.
12	P-995	<u>SCREW</u>
13	P-943	<u>HEX HEAD SCREW</u>
14	P-260	<u>SCREW</u>
15	P-36134	<u>BEARING BRACKET ASSEMBLY</u>
16	P-1561	<u>PIVOT</u>
17	P-8	<u>SET SCREW</u>
18	P-670	<u>C-RING</u>
19	P-6000	<u>SPRING ANCHOR</u> FOR SPRINGS ITEM #8 & #15 PAGE 11.
20	P-8001	<u>SHOULDER SCREW</u>
21	P-36135	<u>PAPER FEELER STOP LEVER</u>
22	P-809	<u>BUSHING</u>
23	P-6001	<u>SPRING ANCHOR</u>
24	P-8000	<u>SHOULDER SCREW</u>
25	P-36137	<u>BEARING BRACKET ASSEMBLY</u> - FOR ALL MODELS (HOWEVER 375 & 9800 DOES NOT NEED ITEM #26 P-808).
26	P-808	<u>BUSHING</u> - FOR OLD STYLE BRACKET.
27	P-44	<u>SCREW</u>
28	P-700	<u>RETAINING RING</u>
29	P-36146  P-36148 P-37148 P-36162	<u>MAIN TIE BAR</u> - (CASTING) ENDS ARE MILLED FOR NEW STYLE UPPER & LOWER PAPER CHUTES ITEMS #8 & #11 THIS PAGE. <u>MAIN TIE BAR</u> - RAISED ENDS FOR OLD STYLE UPPER & LOWER PAPER CHUTES ITEMS #8 & #11 THIS PAGE. <u>MAIN TIE BAR</u> - RAISED ENDS FOR UPPER & LOWER PAPER CHUTES ITEMS #8 & #11 THIS PAGE. <u>SHORT LINK</u> - FINGER OPERATING. CONNECTS TO LEVER ITEM #5 PAGE 6.
30	P-36150	<u>SHAFT ASSEMBLY</u> - ATTACHES TO ITEM #25 THIS PAGE.
31	P-36136	<u>FINGER OPERATING LEVER</u> - NOT SOLD SEPARATELY. SEE ITEM #31 THIS PAGE.
32	P-427	<u>TAPER PIN</u> - (NEW STLYE) LARGE.
33	P-421	<u>TAPER PIN</u> - (OLDS TYLE) SMALL.
34	P-36154 P-37154	<u>FINGER OPERATING SHAFT</u> - 350 & 360. NOT SOLD SEPARATELY. SEE ITEM #31 THIS PAGE. <u>FINGER OPERATING SHAFT</u> - 375 & 9800. NOT SOLD SEPARATELY. SEE ITEM #31 THIS PAGE.
35	P-36156	<u>FINGER OPERATING LEVER</u> - ALL MODELS. NOT SOLD SEPARATELY. SEE ITEM #31 THIS PAGE.
36	P-374	<u>ROLL PIN</u>
37	P-36158	<u>FINGER &amp; TUBE</u> - FOR TUBING SEE ITEMS #1 & #3 PAGE 4. (NEED 4 FOR 350 & 360 - NEED 6 FOR 375 & 9800).
38	P-36160 P-37160	<u>FRONT APRON ASSEMBLY</u> - 350 & 360. <u>FRONT APRON ASSEMBLY</u> - 375 & 9800.
39	P-257	<u>SCREW</u>
40	P-1592	<u>DRILL BIT</u>
41	P-1546	<u>HAND REAMER</u>
42	P-36144	<u>SPRING HOOK</u> - 360 PRO, 375 & 9800 MODELS.
43	P-98156	<u>SENSOR SWITCH COVER</u>
44	P-229	<u>SCREW</u>
45	P-98269	<u>PAPER SENSOR SWITCH ASSEMBLY</u> - 9815 & 9850.
46	P-98581	<u>SPRING</u>
47	P-98974	<u>INTERRUPTER</u>
48	P-189	<u>SCREW</u>
49	P-1839	<u>CABLE CLAMP</u>
50	P-462	<u>NUT</u>

**DRAWING #11**  
**FEEDER UNIT & IMPRESSION CYLINDER**

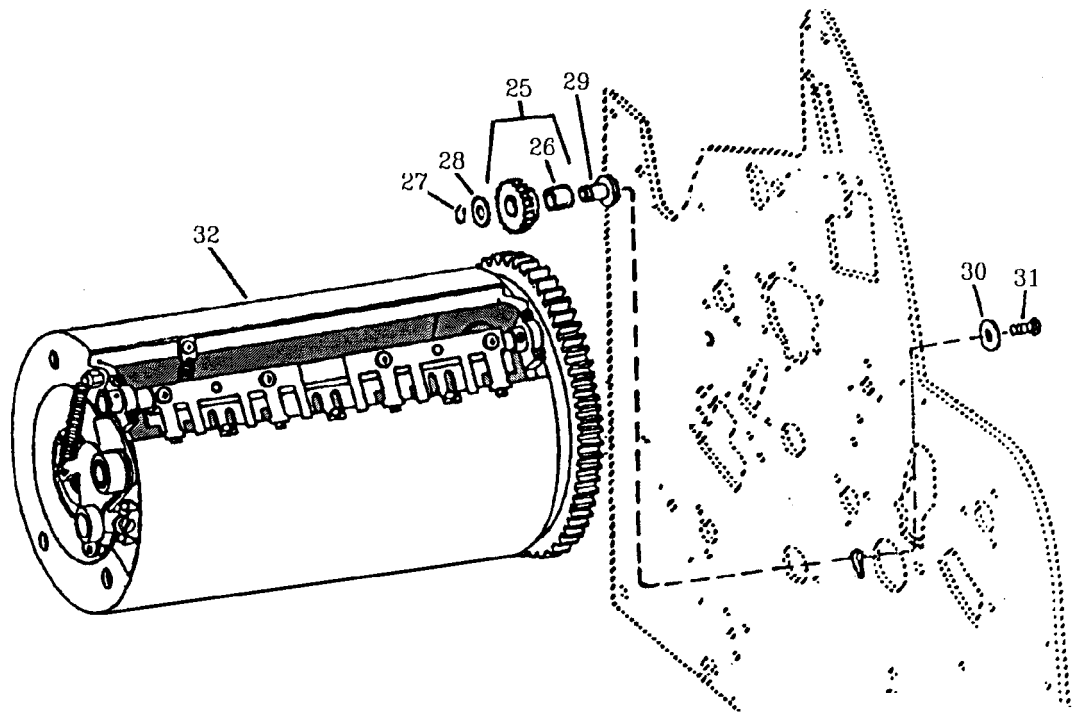
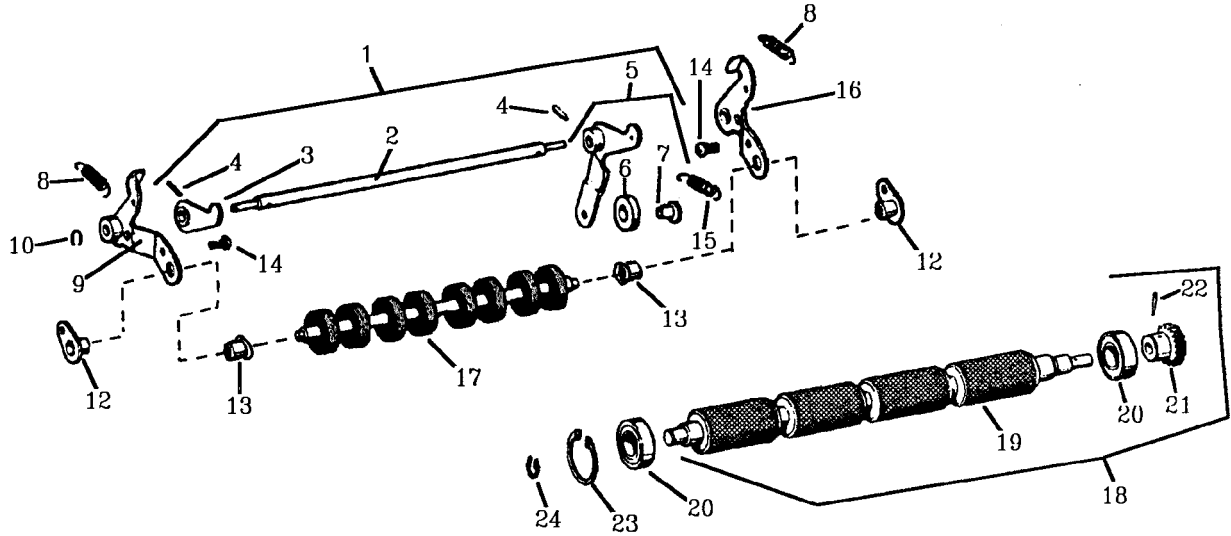

SEE PAGE 12 & 12A FOR IMPRESSION CYLINDERS

**PAGE #11**  
**FEEDER UNIT & IMPRESSION CYLINDER**

KEY #	PART#	DESCRIPTION
1	P-36147	<u>SHAFT &amp; LEVER ASSEMBLY</u> - MOUNTS INTO MAIN TIE BAR, ITEM #29 PAGE 10.
	P-37147	<u>SHAFT &amp; LEVER ASSEMBLY</u> - MOUNTS INTO MAIN TIE BAR, ITEM #29 PAGE 10.
2	P-36149	<u>SHAFT</u>
	P-37149	<u>SHAFT</u>
3	P-36171	<u>LEVER</u>
4	P-349	<u>SPIRAL PIN</u>
5	P-36151	<u>LEVER ASSEMBLY</u>
6	P-764	<u>CAM ROLLER</u> - OPERATES WITH CAM, ITEM #9 PAGE 12.
7	P-319	<u>RIVET</u>
7A	P-10886	<u>WASHER</u> - (2 EA. - NOT SHOWN)
8	P-36177	<u>SPRING</u> - CONNECTS WITH ANCHOR, ITEM #19 PAGE 10.
9	P-36153	<u>LEVER</u> - OPERATORS SIDE.
10	P-670	<u>C-RING</u>
12	P-36175	<u>ARM</u> - SEE NOTE 2.
13	P-1566	<u>PLASTIC BEARING</u> - SEE NOTE 2.
14	P-262	<u>SCREW</u>
15	P-36179	<u>SPRING</u> - CONNECTS WITH ANCHOR, ITEM #19 PAGE 10.
16	P-36155	<u>LEVER</u> - NON-OPERATORS SIDE.
17	P-36157	<u>RUBBER FEED ROLLER</u> - 350 & 360.
	P-37157	<u>RUBBER FEED ROLLER</u> - 375 & 9800.
	P-38157	<u>RUBBER FEED ROLLER</u> - 385. SEE NOTE 2.
18	P-36159	<u>ROLLER ASSEMBLY</u> - MOUNTS INTO MAIN TIE BAR, ITEM #29 PAGE 10.
	P-37159	<u>ROLLER ASSEMBLY</u> - MOUNTS INTO MAIN TIE BAR, ITEM #29 PAGE 10.
19	P-36161	<u>KNURLED LOWER FEED ROLLER</u>
	P-37161	<u>KNURLED LOWER FEED ROLLER</u>
20	P-777	<u>BEARING</u>
21	P-36181	<u>GEAR</u> - DRIVEN BY ITEM #25 THIS PAGE.
22	P-347	<u>SPIRAL PIN</u>
23	P-722	<u>RETAINING RING</u>
24	P-717	<u>RETAINING RING</u>
25	P-36183	<u>IDLER GEAR ASSEMBLY</u> - MOUNTS TO INSIDE OF SIDE FRAME ON NON-OPERATORS SIDE. DRIVES ITEM #21 THIS PAGE & IS DRIVEN BY ITEM #10 PAGE 12.
26	P-822	<u>BUSHING</u>
27	P-703	<u>RETAINING RING</u>
28	P-604	<u>WASHER</u>
29	P-36185	<u>STUD</u>
30	P-1582	<u>WASHER</u>
31	P-944	<u>SCREW</u>
32	P-36163	<u>RESURFACED IMPRESSION CYLINDER ASSEMBLY COMPLETE</u> - 350, 360 CHUTE DEL. NEW STYLE ONLY.
	P-36165	<u>RESURFACED IMPRESSION CYLINDER ASSEMBLY COMPLETE</u> - 350, 360 CHAIN DEL. NEW STYLE ONLY.
	P-35163	<u>RESURFACED IMPRESSION CYLINDER ASSEMBLY COMPLETE</u> - 350 OLD STYLE ONLY.
<p><b>NOTE 1:</b> NEW STYLE IMPRESSION CYLINDER HAS A REMOVABLE PLATE FOR STUD ITEM #13 PAGE 12. OLD STYLE HAS THREADED HOLE FOR STUD TAPPED DIRECTLY INTO CYLINDER.</p> <p><b>NOTE 2:</b> OLD STYLE BRONZE BUSHING FOR THE 385 HAS BEEN REPLACED BY A STEEL ARM AND NYLON BUSHING. ORDER ITEMS #12 &amp; #13 TOGETHER. THIS STYLE IS FOR ROLLERS WITH 1/4" ENDS.</p>		

**DRAWING #12**  
**IMPRESSION CYLINDER - 350, 360, 369**

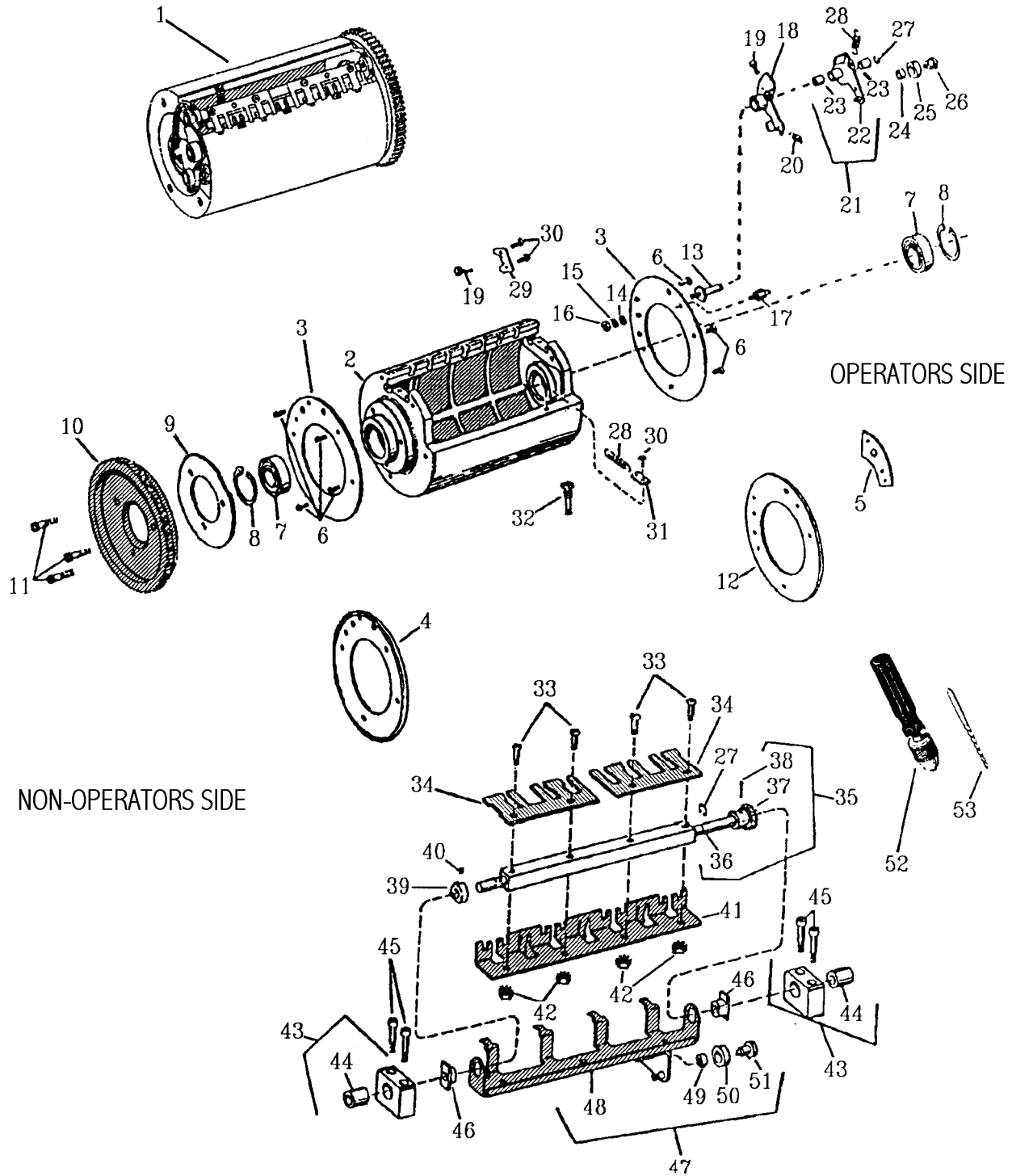

SEE PAGE 40 & 41 FOR IMPRESSION CYLINDER SHAFT AND CONTROL MECHANISM

**PAGE #12**  
**IMPRESSION CYLINDER - 350, 360, 369**

KEY #	PART#	DESCRIPTION
1	P-36163	<u>RESURFACED IMPRESSION CYLINDER ASSEMBLY</u> - COMPLETE - 350, 360 & 369 (CHUTE DELIVERY)
	P-36165	<u>RESURFACED IMPRESSION CYLINDER ASSEMBLY</u> - COMPLETE - 350 & 360 (CHAIN DELIVERY)
	P-35163	<u>RESURFACED IMPRESSION CYLINDER ASSEMBLY</u> - COMPLETE - 350 (CHUTE DELIVERY ONLY)
2	P-36339	<u>CYLINDER BODY</u> - A "STAINLESS STEEL" RESURFACED CYLINDER FOR 360 OR 369.
	P-35339	<u>CYLINDER BODY</u> - (350 ONLY) A "STAINLESS STEEL" RESURFACED CYLINDER.
3	P-35978	<u>CAM PLATE</u> - 350 CHUTE DELIVERY ONLY (OLD STYLE)
4	P-36978	<u>CAM PLATE</u> - 360 CHUTE DELIVERY ONLY
5	P-36187	<u>PLATE BRACKET</u> - FOR CHAIN DELIVERY ONLY, TAKES PLACE OF ITEMS #3 & #12, THIS PAGE.
6	P-81	<u>SCREW</u>
7	P-791	<u>BALL BEARING</u>
8	P-692	<u>RETAINING RING</u>
9	P-36189	<u>CAM</u> - FOR ROLLER SEE ITEM #6, PAGE 11.
10	P-36191	<u>CYLINDER GEAR</u> - DRIVEN BY ITEM #25, PAGE 11, & DRIVES ITEM #8, PAGE 31, & ITEM 1, PAGE 53.
11	P-67	<u>ALLEN HEAD SCREW</u>
12	P-36193	<u>CAM PLATE</u> - 360 OR CHUTE DELIVERY ONLY
13	P-9001	<u>RETAINING RING ANCHOR</u>
14	P-583	<u>WASHER</u> - USED WITH P-9000
15	P-635	<u>LOCK WASHER</u> - USED WITH P-9000
16	P-486	<u>NUT</u> - USED WITH P-9000
17	P-6004	<u>SPRING ANCHOR</u> - CHUTE DELIVERY ONLY
	P-6005	<u>SPRING ANCHOR</u> - CHAIN DELIVERY ONLY
18	P-36203	<u>SEGMENT</u> - SEE ITEM #35, THIS PAGE.
19	P-173	<u>SCREW</u>
20	P-36205	<u>SPRING</u>
21	P-36207	<u>LEVER ASSEMBLY</u> - OPERATED BY ITEM #22, PAGE 41.
22	P-36209	<u>LEVER</u>
23	P-813	<u>BUSHING</u>
24	P-1380	<u>STEEL BUSHING</u>
25	P-1468	<u>CAM ROLLER</u>
26	P-1194	<u>RIVET</u>
27	P-669	<u>C-RING</u>
28	P-36213	<u>SPRING</u> - ATTACHES TO #48, THIS PAGE. 350 OR 360 CHUTE DELIVERY ONLY, & ITEMS #22 & #17, CHAIN OR CHUTE DELIVERY.
29	P-36215	<u>BRACKET</u>
30	P-267	<u>SCREW</u> - 350 ONLY
31	P-36217	<u>SPRING CLIP</u> - 350 CHUTE DELIVERY ONLY
32	P-6006	<u>SPRING ANCHOR</u> - 360
33	P-268	<u>SCREW</u>
34	P-35225	<u>1/2 GRIPPER FINGER</u> - (OLD STYLE 350 ONLY) 2 FINGER
	P-36225	<u>1/4 GRIPPER FINGER</u> - (NEW STYLE) 5 FINGER
35	P-36229	<u>GRIPPER SHAFT ASSEMBLY</u> - CHAIN OR CHUTE DELIVERY, SEE ITEM #18, THIS PAGE.
36	P-36231	<u>GRIPPER IMPRESSION SHAFT</u> - MUST HAVE PROPER TOOLS, USE ITEM #53, THIS PAGE / USE ITEM #52, THIS PAGE / OR USE ITEM #35, THIS PAGE
37	P-36235	<u>GEAR</u> - CHAIN OR CHUTE DELIVERY - MUST HAVE PROPER TOOLS, USE ITEM #53, THIS PAGE / USE ITEM #52, THIS PAGE / OR USE ITEM #35, THIS PAGE
38	P-421	<u>TAPER PIN</u>
39	P-36237	<u>COLLAR</u>
40	P-4	<u>SET SCREW</u>
41	P-35241	<u>PAPER STOP 1/2"</u> - (OLD STYLE) 350 - USED WITH ITEM #35, THIS PAGE
	P-36241	<u>PAPER STOP 1/4"</u> - (NEW STYLE) 360 - USED WITH ITEM #35, THIS PAGE
42	P-471	<u>NUT</u>
43	P-36245	<u>MOUNT</u> - BLOCK
44	P-813	<u>BUSHING</u>
45	P-47	<u>SCREW</u>
46	P-1567	<u>FLANGED BUSHING</u>
47	P-36247	<u>STRIPPER FINGER ASSEMBLY</u> - (CHUTE DELIVERY ONLY), OPERATED BY ITEM #19, PAGE 41.
48	P-36249	<u>STRIPPER FINGER</u> - (CHUTE DELIVERY ONLY) - NOT SOLD SEPARATELY
49	P-1579	<u>BUSHING</u>
50	P-1463	<u>CAM</u> - OPERATES ITEM #19, PAGE 41.
51	P-1593	<u>RIVET</u>
52	P-1546	<u>HAND REAMER</u>
53	P-1565	<u>REAMER BIT</u>

DRAWING #12A  
IMPRESSION CYLINDER - 375, 9800

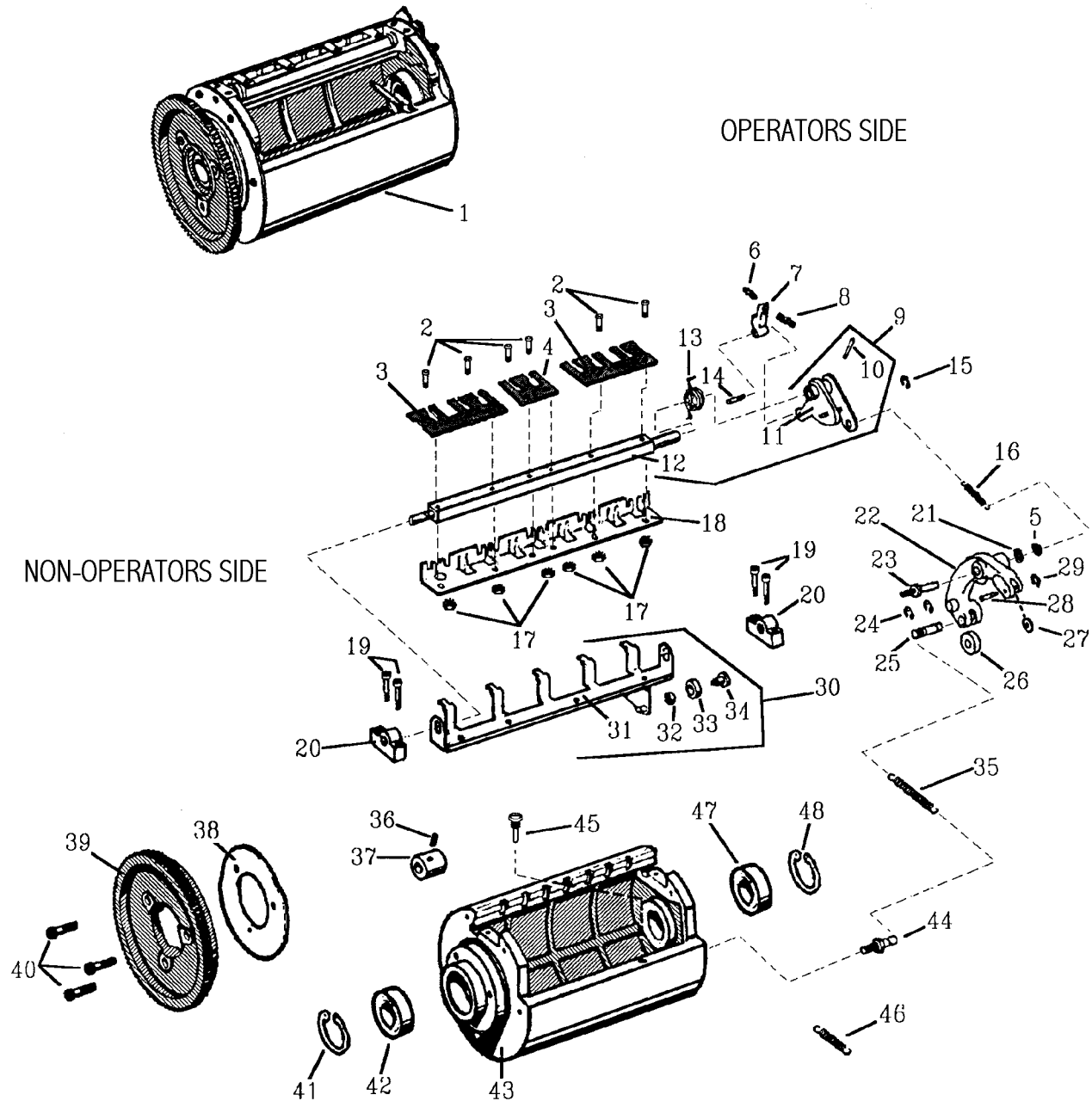



**PAGE #12A**  
**IMPRESSION CYLINDER - 375, 9800**

KEY #	PART#	DESCRIPTION
	NO NO.#	<u>IMPRESSION CYLINDER ASSEMBLY</u> - 375 CHAIN DELIVERY. NOT AVAILABLE AS AN ASSEMBLY.
	NO NO.#	<u>IMPRESSION CYLINDER ASSEMBLY</u> - 9800 CHUTE DELIVERY. NOT AVAILABLE AS AN ASSEMBLY.
	NO NO.#	<u>IMPRESSION CYLINDER ASSEMBLY</u> - 9800 CHAIN DELIVERY. NOT AVAILABLE AS AN ASSEMBLY.
2	P-268	<u>SCREW</u>
3	P-37225	<u>GRIPPER FINGER</u> - 1/4" (4 FINGER)
4	P-37224	<u>GRIPPER FINGER</u> - 1/4" (3 FINGER) CENTER.
5	P-704	<u>RETAINING RING</u>
6	P-860	<u>SET SCREW</u> - ARM ADJUSTMENT.
7	P-37203	<u>OVERLOAD ARM</u>
8	P-36224	<u>SPRING</u>
9	P-37229	<u>GRIPPER SHAFT ASSEMBLY</u> - COMPLETE.
10	P-434	<u>TAPER PIN</u>
11	P-37235	<u>ARM ONLY</u>
12	P-37231	<u>SHAFT ONLY</u>
13	P-98237	<u>SPRING</u> - CD, QPC & PRO (9800) ONLY. OBSOLETE - NOW USING P-37032, ITEM #16, THIS PAGE.
14	P-6042	<u>PIN</u>
15	P-666	<u>C-RING</u>
16	P-37032	<u>SPRING</u>
17	P-471	<u>NUT</u>
18	P-37241	<u>PAPER STOP</u>
19	P-67	<u>SCREW</u>
20	P-37245	<u>MOUNT</u> - BLOCK.
21	P-611	<u>WASHER</u>
22	P-37207	<u>OPERATING ARM</u>
23	P-9053	<u>SPRING ANCHOR</u>
24	P-669	<u>C-RING</u>
25	P-6040	<u>PIN</u>
26	P-1490	<u>CAM ROLLER</u>
27	P-1412	<u>CAM ROLLER</u>
28	P-6042	<u>PIN</u>
29	P-666	<u>C-RING</u>
30	P-37247	<u>STRIPPER FINGER ASSMEBLY</u> - CHUTE DELIVERY ONLY.
31	P-37249	<u>FINGER</u> - NOT AVAILABLE SEPARATELY - USE P-37247, ITEM #30 THIS PAGE.
32	P-1579	<u>BUSHING</u>
33	P-1463	<u>CAM ROLLER</u>
34	P-1593	<u>RIVET</u>
35	P-37205	<u>SPRING</u>
36	P-27	<u>SET SCREW</u>
37	P-1492	<u>COLLAR</u>
38	P-36189	<u>CAM</u>
39	P-36191	<u>CYLINDER GEAR</u> - 375 (Also for 360)
	P-98191	<u>CYLINDER GEAR</u> - 9800 ONLY.
40	P-67	<u>SCREW</u> - USE ON P-36191 ITEM #39, THIS PAGE.
	P-68	<u>SCREW</u> - USE ON P-98191 ITEM #39, THIS PAGE.
41	P-692	<u>RETAINING RING</u> - (INTERNAL)
42	P-791	<u>BALL BEARING</u>
43	P-37992	<u>CYLINDER</u> - RESURFACED STAINLESS STEEL - 375 CHAIN DEL CUSTOMER MUST FURNISH CYLINDER.
	P-37976	<u>CYLINDER</u> - NEW - 375 CHAIN DELIVERY.
	P-37972	<u>CYLINDER</u> - RESURFACED STAINLESS STEEL - 375 CHUTE DEL. CUSTOMER MUST FURNISH CYLINDER.
	P-37339	<u>CYLINDER</u> - NEW - 375 CHUTE DELIVERY.
	P-98992	<u>CYLINDER</u> - RESURFACED STAINLESS STEEL - 9800 CHAIN DEL. CUSTOMER MUST FURNISH CYLINDER.
	P-98976	<u>CYLINDER</u> - NEW - 9800 CHAIN DELIVERY.
	P-98972	<u>CYLINDER</u> - RESURFACED STAINLESS STEEL - 9800 CHUTE DEL. CUSTOMER MUST FURNISH CYLINDER.
	P-98339	<u>CYLINDER</u> - NEW - 9800 CHUTE DELIVERY.
44	P-6043	<u>SPRING ANCHOR</u>
45	P-6006	<u>SPRING ANCHOR</u>
46	P-36213	<u>SPRING</u>
47	P-792	<u>BALL BEARING</u>
48	P-694	<u>RETAINING RING</u> - (INTERNAL)

**DRAWING #13**  
**BLANKET CYLINDER ASSEMBLY - 350, 360, 375**

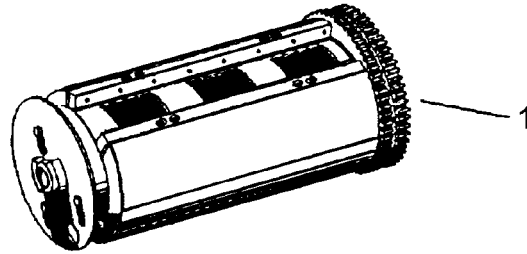

NON-OPERATORS SIDE

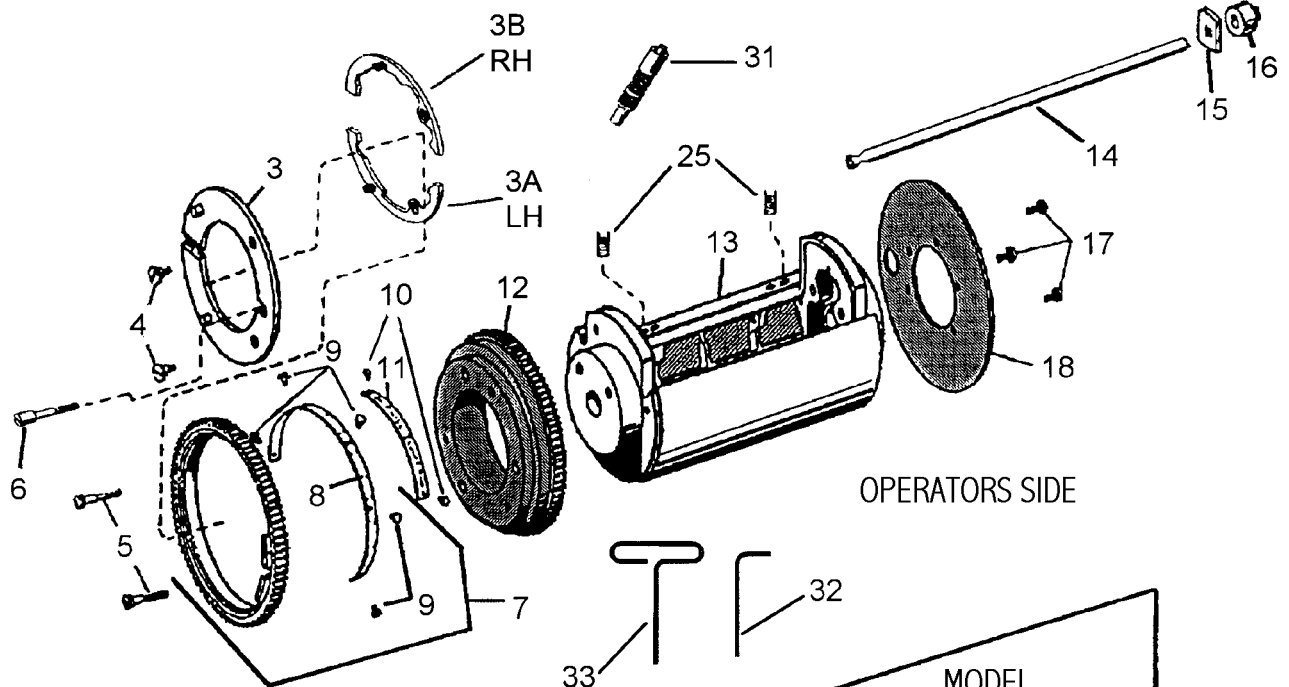

OPERATORS SIDE



MODEL 360 OR 369

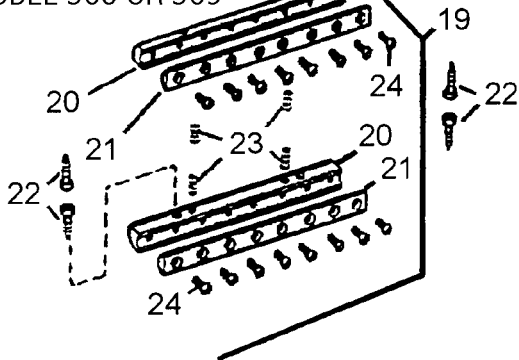

MODEL 350 OR 369M

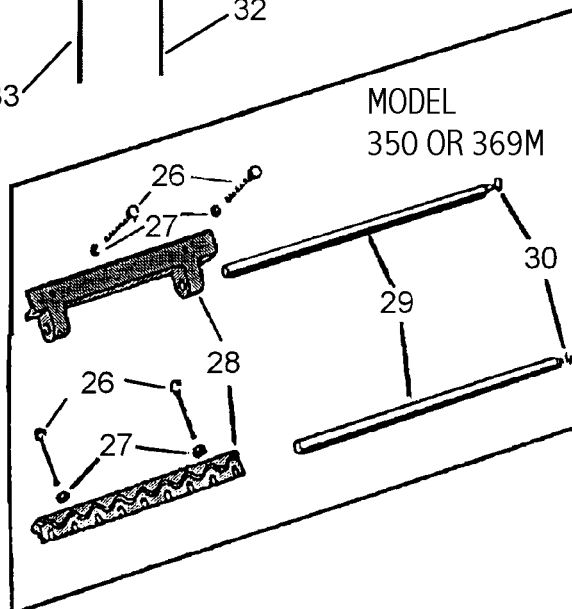

**PAGE #13**  
**BLANKET CYLINDER ASSEMBLY - 350, 360, 375**

KEY #	PART#	DESCRIPTION
1	P-35246	<u>RESURFACED BLANKET CYLINDER ASSEMBLY</u> - 350
	P-36246	<u>RESURFACED BLANKET CYLINDER ASSEMBLY</u> - 360
	NO NO.#	<u>RESURFACED BLANKET CYLINDER ASSEMBLY</u> - 375 - NOT AVAILABLE AS AN ASSEMBLY.
3	P-36178	<u>BLANKET CYLINDER RING</u> - NO LONGER AVAILABLE. <b>SEE NOTE 1.</b>
3A	P-36194	<u>SPLIT SEGMENT RING LEFT HAND 30°</u>
3B	P-36195	<u>SPLIT SEGMENT RING RIGHT HAND 30°</u>
4	P-36188	<u>SHOULDER SCREW</u>
5	P-910	<u>SCREW</u>
	P-68	<u>SCREW</u>
6	P-9000	<u>POSITION SCREW</u>
7	P-36196	<u>BLANKET CYLINDER GEAR ASSEMBLY</u> - OPERATES ITEM #5, PAGE 34.
	P-37196	<u>BLANKET CYLINDER GEAR ASSEMBLY</u> - OPERATES ITEM #5, PAGE 34.
	P-36198	<u>BLANKET CYLINDER GEAR ASSEMBLY</u> - 369 ONLY. OPERATES ITEM #5, PAGE 34.
8	P-36206	<u>SCALE</u>
	P-36202	<u>SCALE</u> - 369 & 375.
9	P-1040	<u>DRIVE SCREW</u>
	P-1039	<u>DRIVE SCREW</u> - 369 ONLY.
10	P-1040	<u>DRIVE SCREW</u>
11	P-36208	<u>VERTICAL PRINT ADJUSTMENT INDICATOR</u>
12	P-36214	<u>BLANKET CYLINDER GEAR</u>
	P-36212	<u>BLANKET CYLINDER GEAR</u> - 369 ONLY
	P-36211	<u>BLANKET CYLINDER GEAR</u> - WIDER GEAR FOR LONGER LIFE.
13	P-35190	<u>RESURFACED BLANKET CYLINDER</u> - 350. SEND IN YOUR OLD CYLINDER AND RECEIVE A \$50.00 CREDIT.
	P-36190	<u>RESURFACED BLANKET CYLINDER</u> - 360. SEND IN YOUR OLD CYLINDER AND RECEIVE A \$50.00 CREDIT.
	P-36976	<u>RESURFACED BLANKET CYLINDER</u> - 369. SEND IN YOUR OLD CYLINDER AND RECEIVE A \$50.00 CREDIT.
	P-37190	<u>RESURFACED BLANKET CYLINDER</u> - 375 NEW - FAST EXCHANGE.
14	P-36180	<u>DRAW ROD</u> - 30° DEGREE PRESSURE ANGLE - OLD STYLE
	P-37180	<u>DRAW ROD</u> - 30° DEGREE PRESSURE ANGLE - OLD STYLE
	P-36308	<u>DRAW ROD</u> - 20° DEGREE PRESSURE ANGLE - NEW STYLE
	P-37308	<u>DRAW ROD</u> - 20° DEGREE PRESSURE ANGLE - NEW STYLE
15	P-36182	<u>DRAW ROD RETAINER</u>
16	P-36186	<u>DRAW ROD NUT</u> - (BLACK) 350, 360, 375 & 9800 NEW STYLE. FOR PRINT ADJUSTMENT DRAW ROD ITEM #36, PAGE 14.
	OBSOLETE	<u>DRAW ROD NUT</u> - (SILVER) 350 & 360 OLD STYLE. NO LONGER AVAILABLE. USE P-36186 or P-36819, ITEM #16.
	P-36819	<u>DRAW ROD NUT</u> - (BLACK) 360 PRO ONLY. FOR PRINT ADJUSTMENT DRAW ROD ITEM #36, PAGE 14.
17	P-275	<u>SCREW</u>
18	P-36210	<u>SHIELD</u>
19	P-36252	<u>BLANKET BAR ASSEMBLY</u> - (COMPLETE)
	P-37252	<u>BLANKET BAR ASSEMBLY</u> - (COMPLETE)
20	P-36256	<u>BLANKET BAR CLAMP</u> - 360 - BOTTOM
	P-37256	<u>BLANKET BAR CLAMP</u> - 375 & 9800 - BOTTOM
21	P-36258	<u>BLANKET BAR CLAMP</u> - 360 - UPPER
	P-37258	<u>BLANKET BAR CLAMP</u> - 375 & 9800 - UPPER
22	P-36204	<u>SCREW</u> - (POINTED) NOT INCLUDED IN ASSEMBLY, P-36252 ITEM #19, THIS PAGE.
23	P-872	<u>SET SCREW</u>
24	P-124	<u>SCREW</u> - (16 TOTAL)
25	P-1821	<u>INSERT SCREW</u> - USED TO REPLACE STRIPPED THREADS IN CYLINDER FOR BLANKET BAR SCREWS, ITEM #22, THIS PAGE. NEED TO USE TOOL P-1822, ITEM #31, THIS PAGE.
26	P-1574	<u>THUMB SCREW</u>
27	P-486	<u>NUT</u>
28	P-35254	<u>BLANKET BAR CLAMP</u> - 350 - UPPER & LOWER, SOLD SEPARATELY
29	P-36250	<u>SHAFT</u> - 350 - SOLD SEPARATELY
30	P-668	<u>SNAP RING</u>
31	P-1822	<u>TOOL</u> - FOR INSERTING ITEM #25, THIS PAGE.
32	P-5974	<u>T-HANDLE ALLEN WRENCH</u> - FOR ITEM #22, THIS PAGE.
33	P-5967	<u>ALLEN WRENCH</u> - FOR ITEM #23, THIS PAGE.

**NOTE 1:** P-36178 SINGLE PIECE RING IS NO LONGER AVAILABLE. USE P-36178-K FOR 350, 360, OR P-37178-K FOR 375, 9800. KIT CONSISTS OF 1) P-36194, 1) P-36195, 1) P-36308 OR P-37308 DEPENDING ON MODEL OF MACHINE.

**NOTE 2:** OLD STYLE 30° AND NEW STYLE 20° DRAW RODS CAN BE DETERMINED AS SHOWN IN FIG. 1.

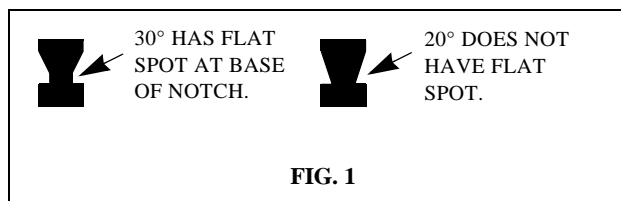

**DRAWING #13A**  
**BLANKET CYLINDER - 9805, 9850**

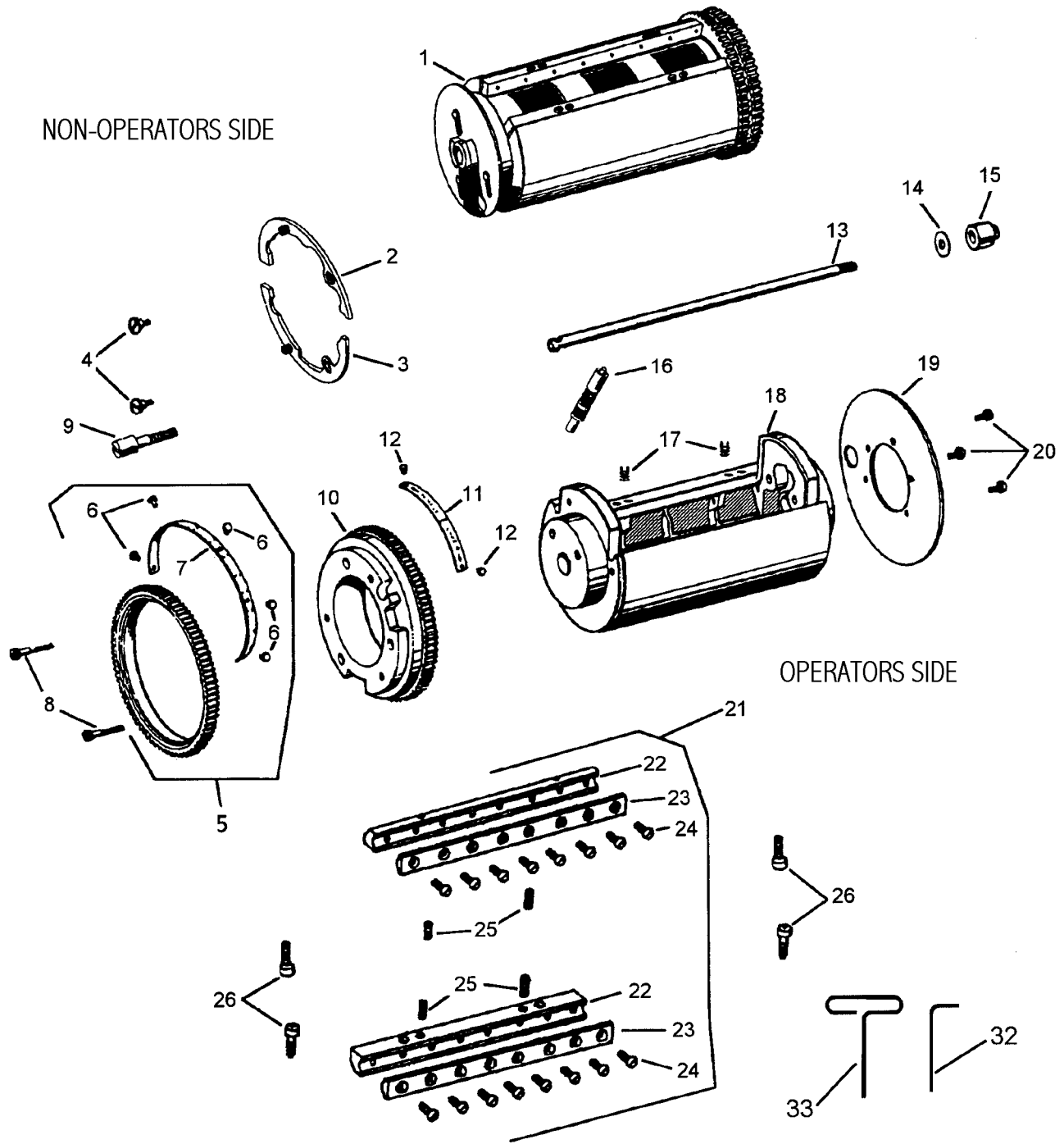

SEE PAGE 13 FOR 350, 360, & 375 BLANKET CYLINDER.

**PAGE #13A**  
**BLANKET CYLINDER - 9805, 9810**

KEY #	PART#	DESCRIPTION
1	NO NO.#	<u>BLANKET CYLINDER ASSEMBLY</u> - 9800 - NOT AVAILABLE AS AN ASSEMBLY.
2	P-36195	<u>SPLIT RING SEGMENT 20°</u> - RIGHT HAND. USE ONLY WITH P-37308, #13 THIS PAGE FOR 9805, 9810.
3	P-36194	<u>SPLIT RING SEGMENT 20°</u> - LEFT HAND. USE ONLY WITH P-37308, #13 THIS PAGE FOR 9805, 9810.
4	P-36188	<u>SHOULDER SCREW</u>
5	P-37196	<u>BLANKET CYLINDER GEAR ASSEMBLY</u> - OPERATES ITEM #5, PAGE 34. SOLD ONLY AS AN ASSEMBLY.
6	P-1040	<u>DRIVE SCREW</u>
7	P-36202	<u>SCALE</u>
8	P-68	<u>SCREW</u>
9	P-9000	<u>POSITION SCREW</u>
10	P-98214	<u>BLANKET CYLINDER GEAR</u>
11	P-36208	<u>SCALE</u>
12	P-1040	<u>DRIVE SCREW</u>
13	P-37308	<u>DRAW ROD 20°</u> - PRESSURE ANGLE. USE ONLY WITH NEW STYLE 20 ° L.H. AND R.H. SEGMENTS, ITEMS #2 & 3, THIS PAGE
	P-37180	<u>DRAW ROD 30°</u> - PRESSURE ANGLE.
14	P-610	<u>WASHER</u>
15	P-36186	<u>DRAW ROD NUT</u> - (BLACK) FOR PRINT ADJUSTMENT DRAW ROD, ITEM #36, PAGE 14.
	P-36184	<u>DRAW ROD NUT</u> - (SILVER) FOR PRINT ADJUSTMENT DRAW ROD, ITEM #36, PAGE 14.
16	P-1822	<u>INSERT TOOL</u>
17	P-1821	<u>INSERT SCREW</u> - USED TO REPLACE STRIPPED THREADS IN CYLINDER FOR BLANKET BAR SCREWS, ITEM #22, THIS PAGE. NEED TO USE P-1822, ITEM #16, THIS PAGE.
18	P-98190	<u>RESURFACED BLANKET CYLINDER</u> - 9805 TO 9850 - NEW. FAST EXCHANGE.
19	P-98210	<u>SHIELD</u>
20	P-943	<u>SCREW</u>
21	P-37252	<u>BLANKET BAR ASSEMBLY</u> - (COMPLETE)
22	P-37256	<u>BLANKET BAR CLAMP</u> - BOTTOM.
23	P-37258	<u>BLANKET BAR CLAMP</u> - TOP.
24	P-124	<u>SCREW</u>
25	P-872	<u>SET SCREW</u>
26	P-36204	<u>SCREW</u> - (POINTED) NOT INCLUDED IN ASSEMBLY P-37252, ITEM #21, THIS PAGE.
27	P-5974	<u>T-HANDLE ALLEN WRENCH</u> - FOR ITEM #26, THIS PAGE.
28	P-5967	<u>ALLEN WRENCH</u> - FOR ITEM #25, THIS PAGE.

**DRAWING #14**  
**BLANKET CYLINDER ASSEMBLY & PRINT ADJUSTMENT MECHANISM - 350, 360, 375, 9800**

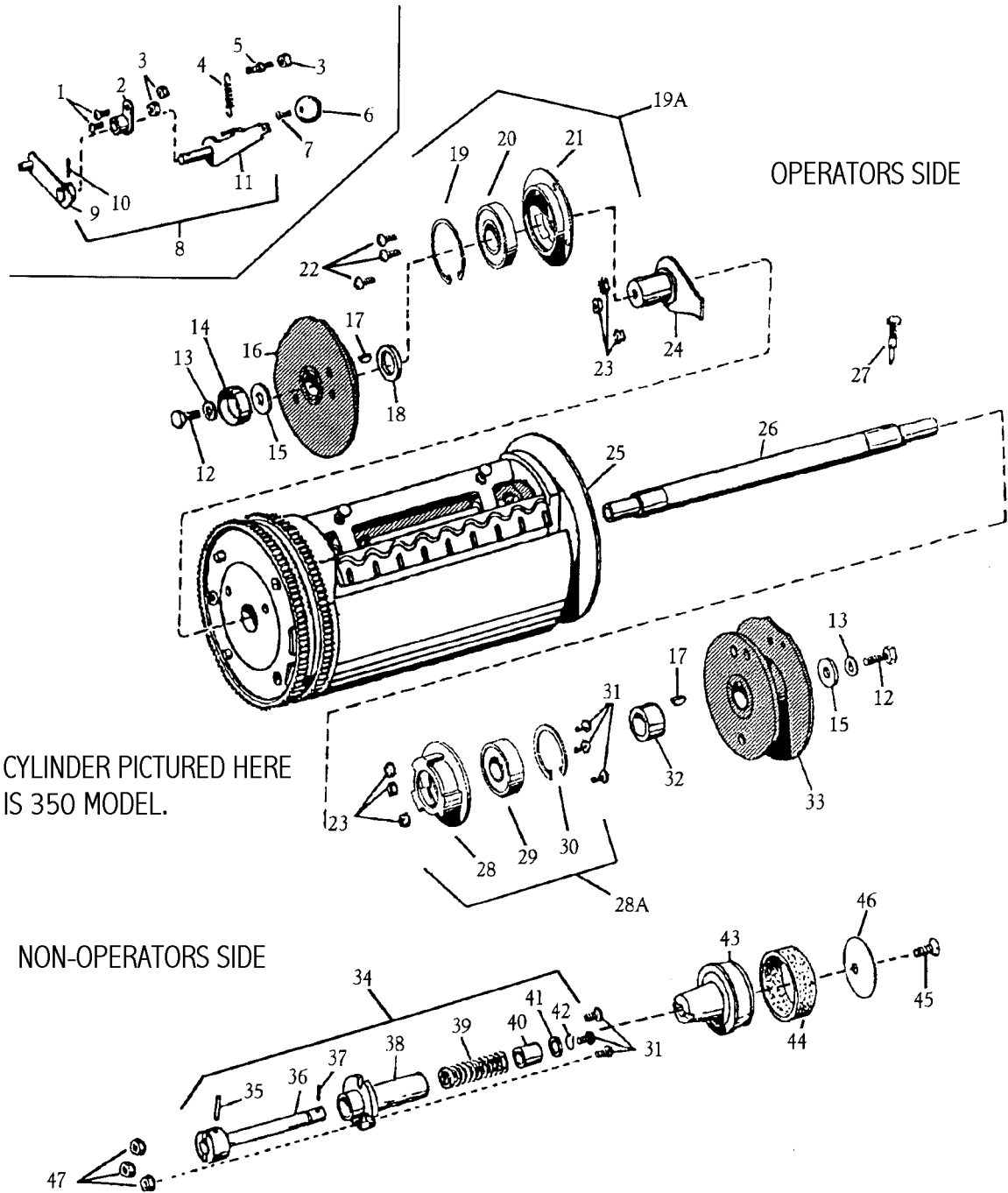

CYLINDER PICTURED HERE IS 350 MODEL.

NON-OPERATORS SIDE

OPERATORS SIDE

## BLANKET CYLINDER ASSEMBLY &amp; PRINT ADJUSTMENT MECHANISM - 350, 360, 375, 9800

KEY #	PART#	DESCRIPTION
1	P-263	<u>SCREW</u>
2	P-36272	<u>BEARING PLATE</u>
3	P-471	<u>KEPS NUT</u>
4	P-36266	<u>SPRING</u>
5	P-6007	<u>SPRING ANCHOR</u>
6	P-36270	<u>IMAGE DEVELOPMENT KNOB</u>
7	P-298	<u>SCREW</u>
8	P-36274	<u>MANUAL IMAGE DEVELOPMENT LEVER ASSEMBLY</u> - FOR OLD STYLE 350 & 360
9	P-36276	<u>LEVER</u> - OPERATES WITH LEVER, ITEMS #30 & #31, PAGE 43. NOT SOLD SEPARATELY.
10	P-380	<u>ROLL PIN</u>
11	P-36278	<u>LEVER</u> - NOT SOLD SEPARATELY.
12	P-102	<u>SCREW</u>
13	P-647	<u>WASHER</u>
14	P-36280	<u>DEFLECTOR</u> - CANNOT BE USED WITH 8" DIA. (OVERSIZED) PULLEY. SEE NOTE! (NOT USED ON 9800)
15	P-1543	<u>WASHER</u>
16	P-36282	<u>CAM ASSEMBLY</u> - SEE CAM FOLLOWER, ITEMS #7 & 17, PAGE 40, NON OPERATOR SIDE
	P-98282	<u>CAM ASSEMBLY</u> - SEE CAM FOLLOWER, ITEMS #7 & 17, PAGE 40, NON OPERATOR SIDE 9815-9850 ONLY.
17	P-551	<u>KEY</u>
18	P-1513	<u>SPACER</u>
19A	P-36283	<u>BEARING HOUSING KIT</u>
19	P-692	<u>RETAINING RING</u>
20	P-791	<u>BALL BEARING</u>
21	P-36288	<u>RIGHT HAND HOUSING</u> - NEW STYLE FOR LONGER LIFE, MOUNTS TO SIDE FRAME, NON OPERATORS SIDE.
22	P-263	<u>SCREW</u>
23	P-471	<u>KEPS NUT</u>
24	P-36284	<u>ARM ASSEMBLY</u> - (350 - 360)
	P-36286	<u>ARM ASSEMBLY</u> - (369)
	P-37284	<u>ARM ASSEMBLY</u> - (375 & 9800)
25	P-35246	<u>RESURFACED COMPLETE CYLINDER ASSEMBLY</u> - (350)
	P-36246	<u>RESURFACED COMPLETE CYLINDER ASSEMBLY</u> - (360)
	NO NO.#	<u>RESURFACED COMPLETE CYLINDER ASSEMBLY</u> - (375 & 9800) - NOT AVAILABLE AS AN ASSEMBLY.
26	P-36290	<u>BLANKET CYLINDER SHAFT</u> - 350 & 360.
	P-37290	<u>BLANKET CYLINDER SHAFT</u> - 375 & 9800.
	P-38290	<u>BLANKET CYLINDER SHAFT</u> - 380, 382, 385.
27	P-36292	<u>SCREW</u>
	P-37292	<u>SCREW</u>
28A	P-36295	<u>BEARING HOUSING KIT</u>
28	P-36294	<u>LEFT HAND HOUSING</u> - NEW STYLE FOR LONGER LIFE, MOUNTS TO LOWER SIDE FRAME, OPERATORS SIDE. (SEE ITEM #19A, THIS PAGE)
29	P-790	<u>BALL BEARING</u>
30	P-691	<u>RETAINING RING</u>
31	P-264	<u>SCREW</u> - PHILLIPS
	P-82	<u>SCREW</u> - HEX HEAD
32	P-36302	<u>SPACER</u>
33	P-35298	<u>CAM ASSEMBLY</u> - OPERATORS SIDE. (350) SEE CAM FOLLOWERS, #49, PAGE 47, & #26, PAGE 43.
	P-36298	<u>CAM ASSEMBLY</u> - OPERATORS SIDE. (360 & 375) SEE CAM FOLLOWERS, #49, PAGE 47, & #26, PAGE 43.
	P-36296	<u>CAM ASSEMBLY</u> - OPERATORS SIDE. (369) SEE CAM FOLLOWERS, #49, PAGE 47, & #26, PAGE 43.
34	P-36234	<u>PRINT ADJUSTING ASSEMBLY</u> - MOUNTS TO SIDE FRAME, ON OPERATORS SIDE.
35	P-392	<u>ROLL PIN</u>
36	P-36236	<u>ROD ASSEMBLY</u> - SEE ITEM #16, PAGE 13.
37	P-350	<u>ROLL PIN</u>
38	P-36238	<u>HOUSING</u>
39	P-36240	<u>SPRING</u>
40	P-1372	<u>BUSHING</u>
41	P-603	<u>WASHER</u> - FOR OLD STYLE.
42	P-703	<u>RETAINING RING</u> - FOR OLD STYLE.
43	P-36242	<u>KNOB</u> - ALL BUT 9800
	P-98242	<u>KNOB</u> - 9800 ONLY
44	P-36244	<u>HAND GRIP TIRE</u>
45	P-300	<u>SCREW</u> - ALL BUT 9800.
	P-8056	<u>SHOULDER SCREW</u> - 9800 ONLY.
46	P-36361	<u>INSERT DISC</u>
47	P-472	<u>NUT</u>
48	P-5949	<u>CYLINDER SHAFT PULLER</u> - BLANKET.

NOTE: IF YOUR PRESS IS EQUIPPED WITH AN 8" DIA. PULLEY YOU MUST REPLACE THE DEFLECTOR WITH A WASHER AND SCREW. (SEE PAGE 34)

**DRAWING #15**  
**MASTER (PLATE) CYLINDER ASSEMBLY - 350**

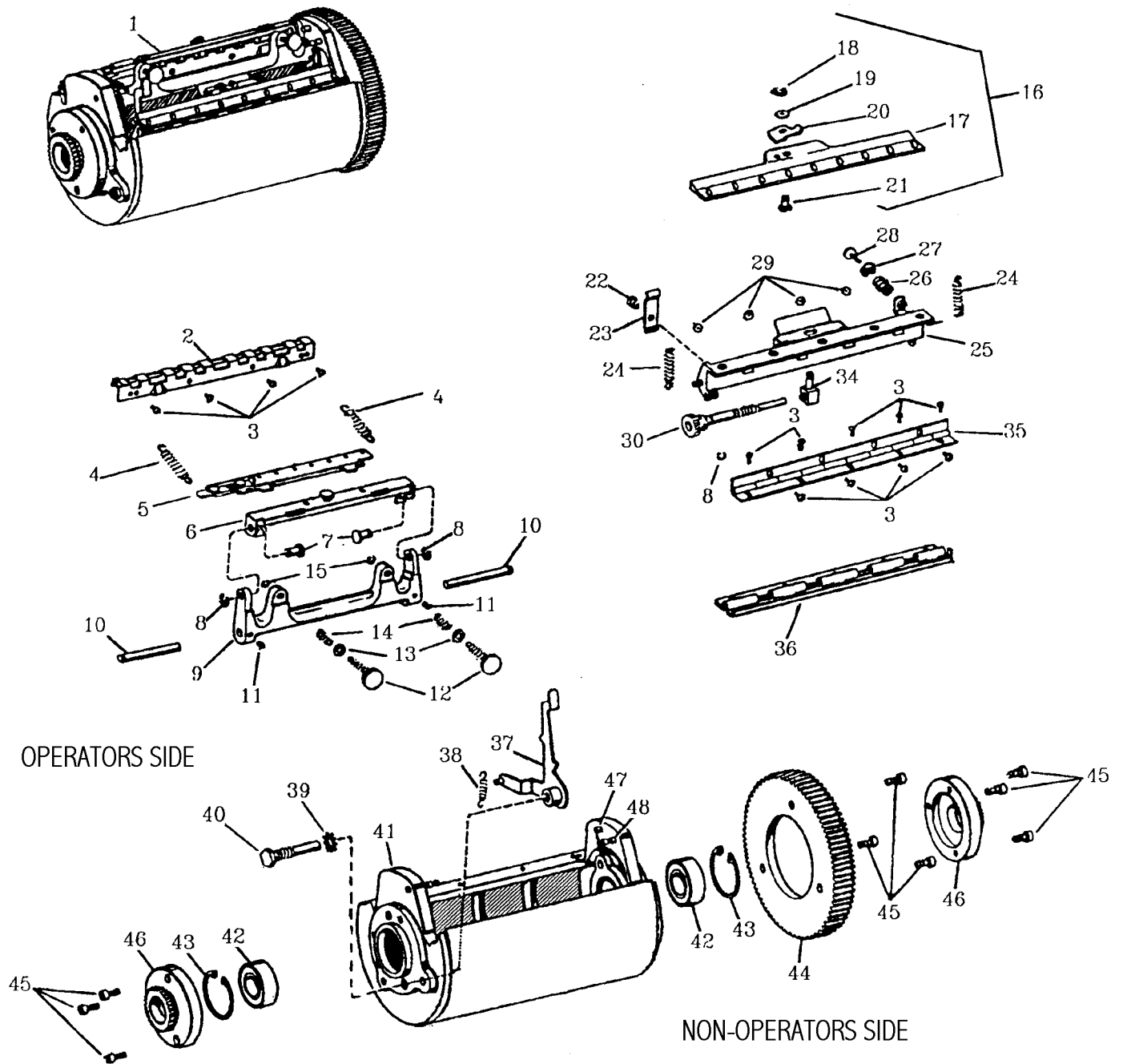



**PAGE #15**  
**MASTER (PLATE) CYLINDER ASSEMBLY - 350**

KEY #	PART#	DESCRIPTION
1	P-35253	<u>RESURFACED 350 MASTER CYLINDER ASSEMBLY</u> - COMPLETE.
2	P-35255	<u>ANVIL</u>
3	P-245	<u>SCREW</u>
4	P-35257	<u>SPRING</u>
5	P-35259	<u>TAIL CLAMP</u> - FOR PREPUNCHED METAL PLATES (ROUND POINT PINS) FOR 350.
	P-35261	<u>TAIL CLAMP</u> - FOR METAL OR PAPER PLATES (NEEDLE POINT PINS) FOR 350.
6	P-35263	<u>MOUNT</u> - FOR TAIL CLAMP.
7	P-35265	<u>PIVOT STUD</u>
8	P-668	<u>RETAINING RING</u>
9	P-35267	<u>TAIL CLAMP MOUNTING BAR</u>
10	P-35269	<u>PIVOT SHAFT</u>
11	P-8	<u>SET SCREW</u>
12	P-1575	<u>THUMB SCREW</u>
13	P-583	<u>WASHER</u>
14	P-35271	<u>SPRING</u>
15	P-666	<u>C-RING</u>
16	P-35273	<u>PIN BAR HEAD CLAMP ADAPTER ASSEMBLY</u> - 9 POINT BAR.
	P-35275	<u>PIN BAR HEAD CLAMP ADAPTER ASSEMBLY</u> - 20 POINT BAR (STANDARD).
17	P-35277	<u>PIN BAR HEAD CLAMP ONLY</u> - 9 POINT.
	P-35279	<u>PIN BAR HEAD CLAMP ONLY</u> - 20 POINT (STANDARD).
18	P-668	<u>RETAINING RING</u>
19	P-654	<u>SPRING WASHER</u>
20	P-35281	<u>LOCKING LEVER</u>
21	P-35217	<u>STUD</u>
22	P-251	<u>SCREW</u>
23	P-35283	<u>LEAF SPRING</u>
24	P-35285	<u>SPRING</u>
25	P-35287	<u>ANGLE CLAMP</u>
26	P-35289	<u>SPRING</u>
27	P-664	<u>C-RING</u>
28	P-35291	<u>THUMB SCREW</u>
29	P-1053	<u>NUT</u>
30	P-35293	<u>ADJUSTING SCREW ASSEMBLY</u>
34	P-35297	<u>BLOCK</u>
35	P-35299	<u>HINGE</u>
36	P-35301	<u>STOP PLATE</u>
37	P-35307	<u>LATCH</u>
38	P-36032	<u>SPRING</u>
39	P-1595	<u>LOCKWASHER</u>
40	P-35309	<u>HEX HEAD PIVOT STUD</u>
41	P-35311	<u>RESURFACED MASTER CYLINDER 350</u> - SEND IN YOUR OLD CYLINDER AND RECEIVE A \$50.00 CREDIT..
42	P-790	<u>BALL BEARING</u>
43	P-691	<u>RETAINING RING</u>
44	P-36313	<u>MASTER CYLINDER GEAR</u> - OPERATES ON GEAR ITEM #47 PAGE 23 & ITEM #21 PAGE 19.
45	P-64	<u>ALLEN HEAD SCREW</u>
46	P-36315	<u>SIDE MOUNT GEAR</u> - OPERATES WITH CONTROL LEVER ITEM #10 PAGE 9 & ITEM #9 PAGE 45.
47	P-3023	<u>GROOVE PIN</u>
48	P-6008	<u>SPRING ANCHOR</u>

**DRAWING #16**  
**MASTER (PLATE) CYLINDER ASSEMBLY - 360, 375**

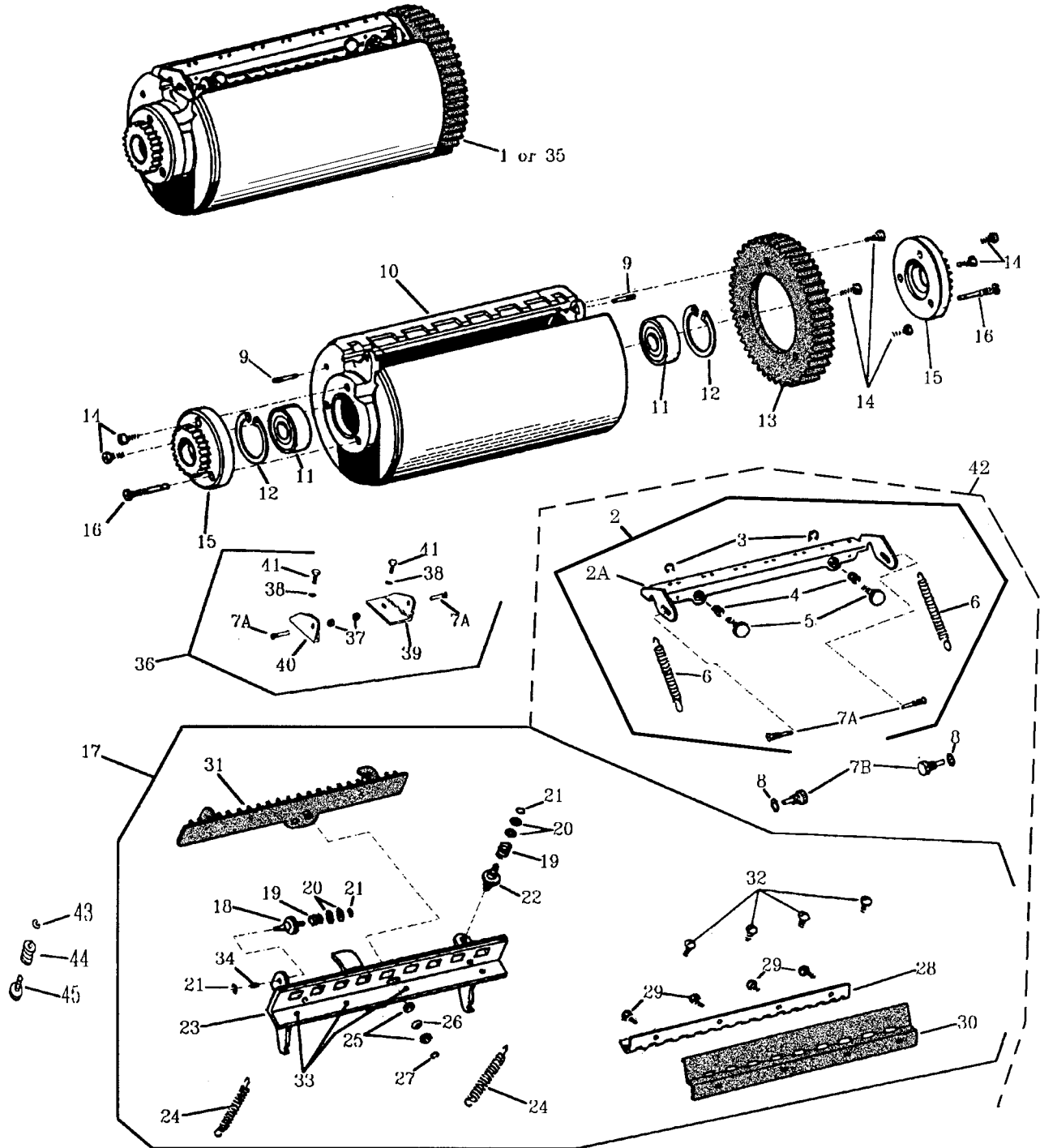

ITEM #42 INCLUDES ITEMS #2A THRU #7A & #17.

**PAGE #16**  
**MASTER (PLATE) CYLINDER ASSEMBLY - 360, 375**

KEY #	PART#	DESCRIPTION
1	P-36253 NO NO.#	<u>RESURFACED MASTER CYLINDER ASSEMBLY</u> - COMPLETE. <u>RESURFACED MASTER CYLINDER ASSEMBLY</u> - NOT AVAILABLE FOR 375 AS AN ASSEMBLY.
2	P-36606 P-37606	<u>TAIL CLAMP ASSEMBLY</u> - 360. CONSISTS OF ITEMS #2 - #7A. <u>TAIL CLAMP ASSEMBLY</u> - 375. CONSISTS OF ITEMS #2 - #7A.
2A	P-36323 P-37323	<u>TAIL CLAMP</u> - 360. <u>TAIL CLAMP</u> - 375.
3	P-669	<u>C-RING</u>
4	P-36325	<u>SPRING</u>
5	P-1027	<u>THUMB SCREW</u>
6	P-36327	<u>SPRING</u>
7A	P-36331	<u>PIVOT SCREW</u> - NEW STYLE - FLAT HEAD.
7B	P-36329	<u>PIVOT SCREW</u> - OLD STYLE 360 ONLY - FILLISTER HEAD.
8	P-645	<u>LOCK WASHER</u>
9	P-6002 P-6052	<u>SPRING ANCHOR</u> - 360 ONLY. <u>SPRING ANCHOR</u> - 375, 9800.
10	P-36311 P-36911 P-37311	<u>CYLINDER BODY</u> - RESURFACED (STAINLESS STEEL) 360. SEND IN YOUR OLD CYLINDER AND RECEIVE A \$50.00 CREDIT. <u>CYLINDER BODY</u> - RESURFACED (STAINLESS STEEL) 369. SEND IN YOUR OLD CYLINDER AND RECEIVE A \$50.00 CREDIT. <u>CYLINDER BODY</u> - NEW - 375. SEND IN YOUR OLD CYLINDER AND RECEIVE A \$50.00 CREDIT.
11	P-790	<u>BALL BEARING</u>
12	P-691	<u>RETAINING RING</u>
13	P-36313	<u>MASTER CYLINDER GEAR</u> - OPERATES GEAR, ITEM #47, PAGE 23 & ITEM #21, PAGE 19.
14	P-64	<u>ALLEN HEAD SCREW</u>
15	P-36315 P-37315	<u>SIDE MOUNT GEAR</u> - 360 - RUNS GEAR, ITEM #9, PAGE 45, & ITEM #10, PAGE 19. <u>SIDE MOUNT GEAR</u> - 375 - RUNS GEAR, ITEM #9, PAGE 45, & ITEM #10, PAGE 19.
16	P-6012 P-6051	<u>SPRING ANCHOR</u> - 360 - NOT NEEDED ON A 350. <u>SPRING ANCHOR</u> - 375.
17	P-36352 P-37352	<u>UNIVERSAL HEAD CLAMP KIT</u> - 360 - WORKS WITH PAPER OR METAL PLATES - (ALSO INCLUDES #32, P-1052). <u>UNIVERSAL HEAD CLAMP KIT</u> - 375 - WORKS WITH PAPER OR METAL PLATES - (ALSO INCLUDE #32, P-1052).
18	P-36347	<u>LATERAL ADJUSTMENT KNOB</u>
19	P-36349	<u>SPRING</u>
20	P-569	<u>WASHER</u>
21	P-666	<u>C-RING</u>
22	P-36351	<u>VERTICAL ADJUSTING KNOB</u> - ATTACHES TO REPLACEMENT INSERT.
23	P-36353 P-37353	<u>PIN BAR MOUNT</u> - COMES WITH ITEMS #33 & #34, THIS PAGE <u>PIN BAR MOUNT</u> - COMES WITH ITEMS #33 & #34, THIS PAGE.
24	P-36032	<u>SPRING</u>
25	P-586	<u>WASHER</u>
26	P-1049	<u>SPRING WASHER</u>
27	P-668	<u>RETAINING RING</u>
28	P-36299	<u>HINGE</u> - 360, 375.
29	P-892	<u>SCREW</u>
30	P-36359 P-37359 P-36357	<u>STOP PLATE</u> - 360 - FOR STRONGER TENSION (3/32 LIP) <u>STOP PLATE</u> - 375 - FOR STRONGER TENSION (3/32 LIP) <u>STOP PLATE</u> - 360 - FOR LIGHTER TENSION (1/64 LIP)
31	P-36345 P-37345	<u>PIN BAR HEAD CLAMP</u> - 360 <u>PIN BAR HEAD CLAMP</u> - 375
32	P-1052	<u>SCREW</u> - INCLUDED WITH ITEM 17 & 42.
33	P-1610	<u>REPLACEMENT INSERT</u> - ATTACHES TO PIN BAR MOUNT
34	P-1609	<u>REPLACEMENT INSERT</u> - ATTACHES TO PIN BAR MOUNT
35	P-36341	<u>CONVERTED MASTER CYLINDER FROM 369 TO 360 HEAD CLAMP ASSEMBLY</u> - CONSISTS OF MACHINING & LABOR & ITEMS #2 - #7A, #9, #17 & #36, WITH CUSTOMER FURNISHED CYLINDER.
36	P-36333	<u>EAR KIT</u> - TO CONVERT MODEL 369 TO 360 STANDARD CLAMPS. MACHINING MUST BE DONE ON THE CYLINDER BEFORE THIS KIT CAN BE USED. SEE ITEM 35 THIS PAGE.
37	P-486	<u>NUT</u> - (2 ea. with kit)
38	P-635	<u>LOCK WASHERS</u> - (2 ea. with kit)
39	P-36337	<u>L.H. EAR</u>
40	P-36335	<u>R.H. EAR</u>
41	P-86	<u>SCREW</u> - (2 ea. with kit)
42	P-36354 P-37354	<u>COMPLETE HEAD &amp; TAIL CLAMP ASSEMBLY</u> - 360 - CONSISTS OF ITEMS #2, 3, 4, 5, 6, 7A, 17, 32. <u>COMPLETE HEAD &amp; TAIL CLAMP ASSEMBLY</u> - 375 - CONSISTS OF ITEMS #2, 3, 4, 5, 6, 7A, 17, 32.
43	P-664	<u>C-RING</u>
44	P-36309	<u>SPRING</u> - LEVELER (OLD STYLE CLAMP ONLY)
45	P-1573	<u>SCREW</u> - LEVELER (OLD STYLE CLAMP ONLY)



**PAGE #17**  
**MASTER (PLATE) CYLINDER ASSEMBLY - 369**

KEY #	PART#	DESCRIPTION
1	P-36953	<u>RESURFACED MASTER CLYINDER ASSEMBLY</u> - COMPLETE 369
2	P-36363	<u>PLATE CLAMP ADJUSTING LEVER ASSEMBLY</u> - 369 ONLY
3	P-36365	<u>LEVER</u>
4	P-36367	<u>CAM ROLLER</u>
5	P-1826	<u>WASHER</u>
6	P-698	<u>RETAINING RING</u>
7	P-29	<u>SET SCREW</u>
8	P-37	<u>ALLEN HEAD SCREW</u>
9	P-36369	<u>HOUSING</u>
10	P-684	<u>RETAINING RING</u>
11	P-36333	<u>EAR KIT</u> - CYLINDERS CONVERTED FROM 369 MODELS TO 360 MODELS. MACHINING MUST BE DONE ON CYLINDER BEFORE THIS KIT CAN BE USED. PLEASE CHECK WITH DEALER.
12	P-86	<u>MOUNTING SCREW</u>
13	P-635	<u>LOCK WASHER</u>
14	P-486	<u>HEX NUT</u>
15	P-36337	<u>LEFT HAND EAR</u>
16	P-36335	<u>RIGHT HAND EAR</u>
17	P-36331	<u>PIVOT SCREW</u>
18	P-36911	<u>MASTER CYLINDER</u> - RESURFACED "STAINLESS STEEL". SEND IN YOUR OLD CYLINDER & RECEIVE A \$50.00 CREDIT.
	P-36983	<u>MASTER CYLINDER</u> - CONVERTED FROM 369 TO 360 STANDARD (WITH CUSTOMER FURNISHED CYLINDER)
19	P-690	<u>BEARING</u>
20	P-691	<u>RETAINING RING</u>
21	P-36313	<u>MASTER CYLINDER GEAR</u> - RUNS ON ITEM #47, PAGE 23 & ITEM #10, PAGE 19.
22	P-36315	<u>SIDE MOUNT GEAR</u> - RUNS GEAR ITEM #9, PAGE 45 & ITEM #10, PAGE 19.
22A	P-36312	<u>SIDE MOUNT GEAR</u> - NEEDED FOR 369 BUT CAN BE USED ON 350/360/375/9800.
23	P-64	<u>ALLEN HEAD SCREW</u>
24	P-8004	<u>SHOULDER SCREW</u>
25	P-6013	<u>SPRING ANCHOR</u> - CONNECTS TO ITEM #28, THIS PAGE
26	P-6012	<u>SPRING ANCHOR</u> - CONNECTS TO ITEM #32, THIS PAGE
27	P-6001	<u>SPRING ANCHOR</u> - CONNECTS TO ITEM #51, THIS PAGE
28	P-36327	<u>SPRING</u> - CONNECTS TO ITEMS #25 & #29, THIS PAGE
29	P-36375	<u>TAIL CLAMP BAR</u>
30	P-36377	<u>LEFT HAND TAIL ARM</u> - OPERATOR SIDE
31	P-471	<u>KEPS NUT</u>
32	P-36619	<u>SPRING</u> - CONNECTS TO ITEM #26, THIS PAGE, INSIDE CYLINDER
33	P-669	<u>C-RING</u> - CONNECTS TO ITEM 26, THIS PAGE
34	P-36379	<u>RIGHT HAND TAIL ARM</u> - NON OPERATOR SIDE
35	P-666	<u>C-RING</u>
36	P-36325	<u>SPRING</u>
37	P-1027	<u>THUMB SCREW</u>
38	P-244	<u>SCREW</u>
39	P-36381	<u>PLATE CLAMP BASE GRIPPER</u>
40	P-36383	<u>PLATE STOP STRIPPER</u>
41	P-36385	<u>PLATE CLAMP BAR ASSEMBLY</u>
42	P-36387	<u>PLATE CLAMP PIVOT BAR</u> - NOT SOLD SEPARATELY - MUST BUY ASSEMBLY, P-36385, #41, THIS PAGE.
43	P-349	<u>SPIRAL PIN</u>
44	P-36389	<u>PIVOT ARM</u> - NOT SOLD SEPARATELY - MUST BUY ASSEMBLY, P-36385, #41, THIS PAGE.
45	P-36391	<u>PIVOT BRACKETS</u>
46	P-929	<u>SHOULDER SCREW</u>
47	P-57	<u>SCREW</u>
48	P-1597	<u>BRACKET MOUNTING SCREW</u>
49	P-36393	<u>MOUNTING BAR</u>
50	P-6014	<u>SPRING ANCHOR</u>
51	P-36397	<u>SPRING</u> - CONNECTS TO #27 & #50, THIS PAGE

DRAWING #17A  
MASTER (PLATE) CYLINDER - 9800

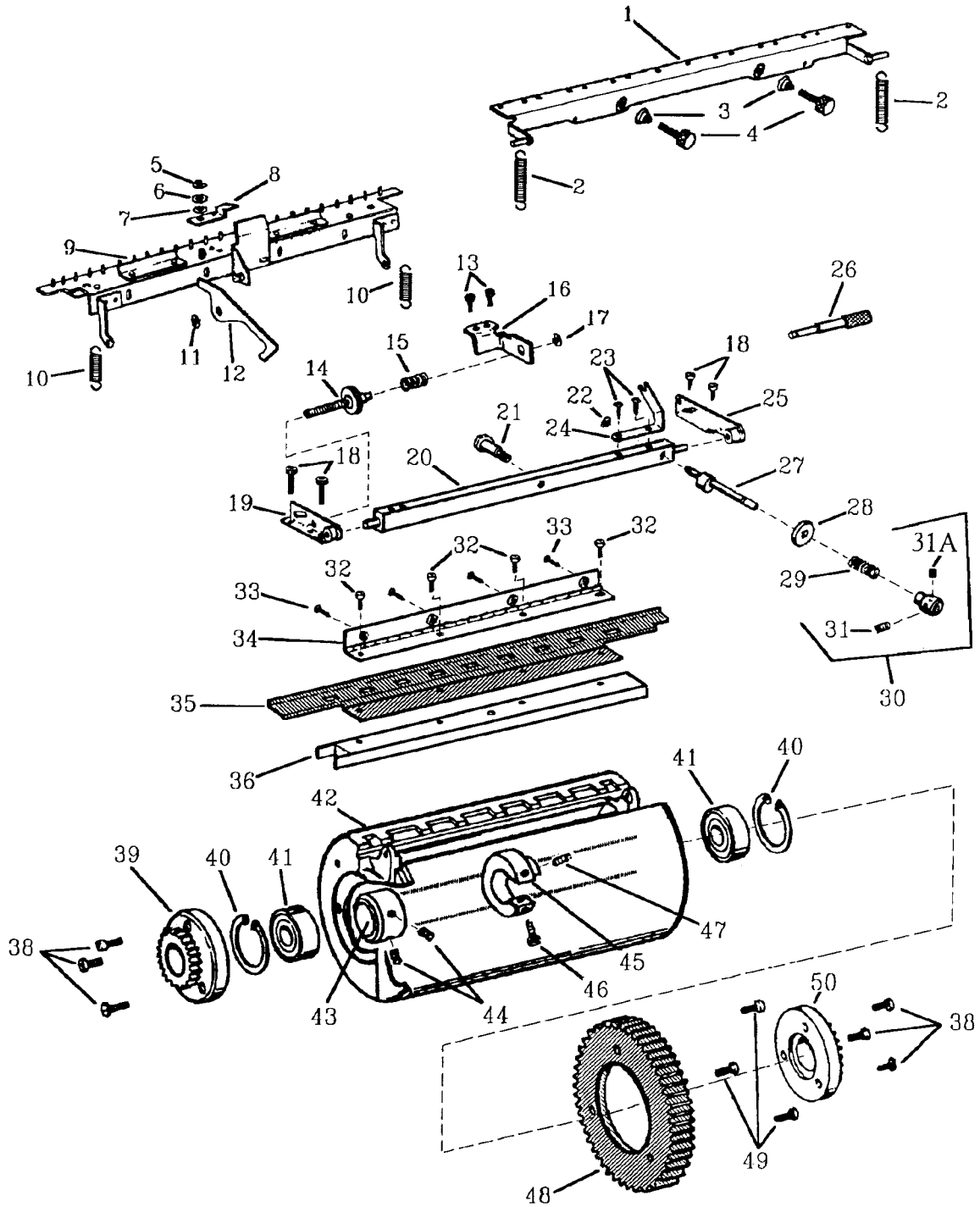

**PAGE #17A**  
**MASTER (PLATE) CYLINDER ASSEMBLY - 9800**

KEY #	PART#	DESCRIPTION
1	P-98323	<u>TAIL CLAMP</u>
2	P-98213	<u>SPRING</u>
3	P-36325	<u>SPRING</u>
4	P-1027	<u>THUMB SCREW</u>
5	P-668	<u>C-RING</u>
6	P-586	<u>WASHER</u>
7	P-655	<u>WASHER</u>
8	P-98365	<u>LOCKOUT LEVER</u>
9	P-98353	<u>PIN BAR MOUNT</u> - THIS STYLE HAS NO THREADED INSERTS. (SEE ITEM #23, PAGE 16)
10	P-36213	<u>SPRING</u> - CONNECTS TO ITEMS #1 & #22 THIS PAGE.
11	P-669	<u>C-RING</u>
12	P-98307	<u>LATCH</u>
13	P-37	<u>SCREW</u>
14	P-98347	<u>THUMB SCREW</u>
15	P-36349	<u>SPRING</u>
16	P-98181	<u>LATERAL ADJUSTMENT BRACKET</u>
17	P-666	<u>C-RING</u>
18	P-43	<u>SCREW</u>
19	P-98153	<u>BRACKET</u> - OPERATORS SIDE
20	P-98387	<u>BAR</u>
21	P-8042	<u>SHOULDER PIVOT SCREW</u>
22	P-668	<u>C-RING</u>
23	P-257	<u>SCREW</u>
24	P-98171	<u>CLAMP POSITIONING BRACKET</u>
25	P-98379	<u>BRACKET</u> - NON-OPERATORS SIDE
26	P-6052	<u>SPRING ANCHOR</u> - INSIDE CYLINDER. FOR SPRING ITEM #2, THIS PAGE.
27	P-98351	<u>ECCENTRIC PIN</u> - SWIVEL ADJUSTMENT
28	P-592	<u>WASHER</u>
29	P-36707	<u>SPRING</u>
30	P-98175	<u>KNOB ASSEMBLY</u>
31	P-4	<u>SET SCREW</u>
31A	P-350	<u>ROLL PIN</u>
32	P-43	<u>SCREW</u>
33	P-253	<u>SCREW</u>
34	P-98299	<u>HINGE ASSEMBLY</u>
35	P-98359	<u>STOP PLATE</u>
36	P-98393	<u>ADJUSTMENT BAR</u>
37	P-98352	<u>HEAD CLAMP KIT</u> - NOT ILLUSTRATED. CONSISTS OF ITEMS #9,13-17,19-24,27,30,32, & 34-36.
38	P-64	<u>SCREW</u>
39	P-37315	<u>SIDE MOUNT GEAR</u> - OPERATORS SIDE. RUNS GEAR ITEM #9, PAGE 45 & ITEM #10, PAGE 19.
40	P-694	<u>RETAINING RING</u> - INTERNAL
41	P-792	<u>BEARING</u>
42	P-98311	<u>CYLINDER BODY</u> - NEW - 9800. FAST EXCHANGE.
43	P-98369	<u>COLLAR</u>
44	P-27	<u>SET SCREW</u>
45	P-98445	<u>COLLAR ASSEMBLY</u>
46	P-66	<u>SCREW</u>
47	P-29	<u>SET SCREW</u>
48	P-98313	<u>MASTER CYLINDER GEAR</u>
49	P-65	<u>SCREW</u>
50	P-37315	<u>SIDE MOUNT GEAR</u> - NON-OPERATORS SIDE. RUNS GEAR ITEM #9, PAGE 45 & ITEM #10, PAGE 19.

**DRAWING #18**  
**WATER DUCTOR ROLLER & WATER FOUNTAIN**

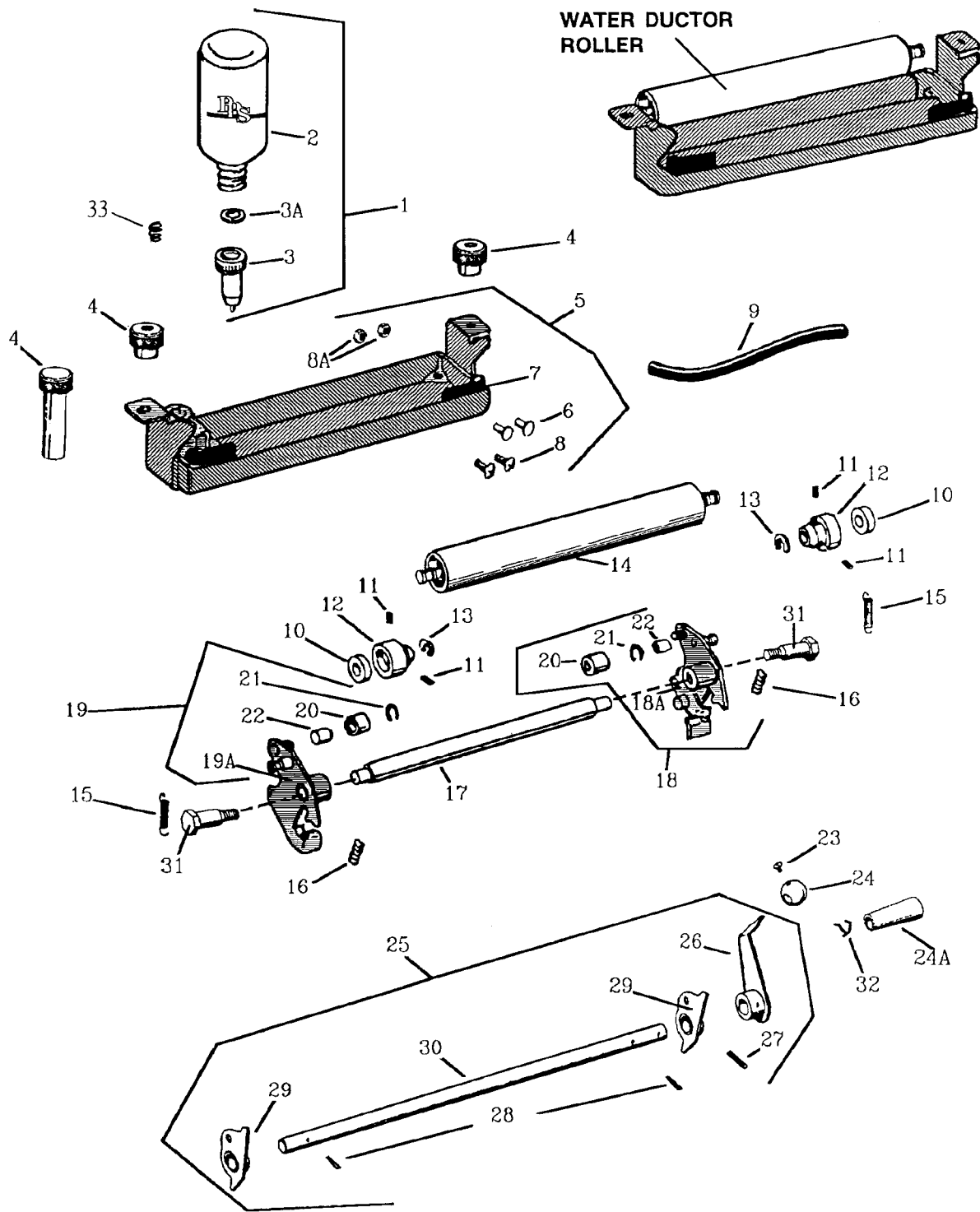



**PAGE #18**  
**WATER DUCTOR ROLLER & WATER FOUNTAIN**

KEY #	PART#	DESCRIPTION
1	P-1915	<u>1-QUART BOTTLE, VALVE, &amp; CAP ASSEMBLY</u>
	P-1919	<u>2-QUART BOTTLE, VALVE, &amp; CAP ASSEMBLY</u>
2	P-1900	<u>1-QUART BOTTLE</u>
	P-1901	<u>2-QUART BOTTLE</u>
3	P-1903	<u>CAP &amp; VALVE ASSEMBLY - WITH WASHER</u>
3A	P-1383	<u>VALVE WASHER</u>
4	P-546	<u>TROUGH MOUNTING KNOB - ON 369 USE ON OPERATORS SIDE, ON 350 OR 360 &amp; 9800 USE ON OPERATORS SIDE OR NON-OPERATORS SIDE.</u>
	P-36304	<u>TROUGH MOUNTING KNOB - ON 369 USE ON NON-OPERATORS SIDE</u>
5	P-36316	<u>TROUGH - 350-360 - MOUNTS TO FRAMES, ITEMS #3 &amp; #4, PAGE 19.</u>
	P-36318	<u>TROUGH - 369</u>
	P-37316	<u>TROUGH - 375 &amp; 9800</u>
6	P-318	<u>RIVET - FOR DEFLECTOR (ITEMS #8 &amp; #8A CAN BE USED IN PLACE OF THIS RIVET) 4 PER FOUNTAIN</u>
7	P-1548	<u>WATER DEFLECTOR</u>
8	P-155	<u>SCREW - FOR DEFLECTOR P-1548 (4 PER FOUNTAIN) OR USE P-318 RIVET</u>
8A	P-460	<u>NUT - FOR DEFLECTOR P-1548 (4 PER FOUNTAIN) OR USE P-318 RIVET</u>
9	P-1549	<u>HOSE</u>
10	P-746	<u>BALL BEARING</u>
11	P-8	<u>SET SCREW</u>
12	P-36322	<u>BEARING HOUSING</u>
13	P-686	<u>RETAINING RING</u>
14	P-35050	<u>WATER DUCTOR ROLLER - (350) RUBBER</u>
	P-36050	<u>WATER DUCTOR ROLLER - (360) RUBBER</u>
	P-36342	<u>WATER DUCTOR ROLLER - (360) CHROME, USE ON "ALCOHOL SYSTEM ONLY" SEE DRAWING 19, ITEM #23 (P-36374)</u>
	P-37050	<u>WATER DUCTOR ROLLER - (375/9800) RUBBER</u>
	P-37342	<u>WATER DUCTOR ROLLER - (375/9800) CHROME, USE ON "ALCOHOL SYSTEM ONLY" SEE DRAWING #19, ITEM #23 (P-37374)</u>
15	P-36328	<u>SPRING - CONNECTS TO ANCHOR ON FRAMES, ITEMS #3 OR #3A, #4 OR #4A, PAGE 19</u>
16	P-36330	<u>COMPRESSION SPRING - FITS ON ITEM #18A &amp; #19A</u>
17	P-36332	<u>TIE BAR</u>
	P-37332	<u>TIE BAR</u>
18	P-36326	<u>CARRIER ASSEMBLY - OPERATOR SIDE, ATTACHES TO FRAME ITEM #4, PAGE 19. OPERATES CAM, ITEM #13, PAGE 20. INCLUDES ITEMS #18A, #20, #21, #22. SEE ITEM #1, PAGE 37.</u>
18A	P-36320	<u>CARRIER - OPERATOR SIDE. (PART OF ITEM #18 THIS PAGE) INCLUDES ITEM #22.</u>
19	P-36324	<u>CARRIER ASSEMBLY - NON OPERATOR SIDE. ATTACHES TO FRAME ITEM #4, PAGE 19, OPERATES CAM, ITEM #13, PAGE 20. INCLUDES ITEMS #19A, #20, #21, &amp; #22. SEE ITEM #1, PAGE 37.</u>
19A	P-36321	<u>CARRIER - NON OPERATOR SIDE. PART OF ITEM #19, THIS PAGE</u>
20	P-1224	<u>BUSHING - PART OF ITEMS #18 &amp; #19, THIS PAGE</u>
21	P-667	<u>RETAINING RING - PART OF ITEMS #18 &amp; #19, THIS PAGE</u>
22	P-1419	<u>ROLLER - PART OF ITEMS #18 &amp; #19, THIS PAGE</u>
23	P-207	<u>SCREW</u>
24	P-36270	<u>KNOB</u>
24A	P-36062	<u>KNOB - 9800</u>
25	P-36334	<u>SHAFT ASSEMBLY - MOUNTS INTO FRAMES, ITEMS #3 &amp; #4, PAGE 19.</u>
	P-37334	<u>SHAFT ASSEMBLY - MOUNTS INTO FRAMES, ITEMS #3 &amp; #4, PAGE 19,</u>
	P-98334	<u>SHAFT ASSEMBLY - MOUNTS INTO FRAMES, ITEMS #3 &amp; #4, PAGE 19.</u>
26	P-36336	<u>LEVER ASSEMBLY - ATTACHES TO OUTSIDE OF FRAME ITEM #4, PAGE 19.</u>
	P-98336	<u>LEVER ASSEMBLY - ATTACHES TO OUTSIDE OF FRAME ITEM #4, PAGE 19.</u>
27	P-382	<u>ROLL PIN</u>
28	P-423	<u>TAPER PIN - IN SHAFT ASSEMBLY - CONSISTS OF 2</u>
29	P-36338	<u>CAM ASSEMBLY - IN SHAFT ASSEMBLY - CONSISTS OF 2</u>
30	P-36340	<u>SHAFT - 350 &amp; 360 (NOT SOLD SEPARATELY.)</u>
	P-37340	<u>SHAFT - 375 &amp; 9800. (NOT SOLD SEPARATELY. USE P-37334 SHAFT ASSEMBLY FOR 375, &amp; P-98334 SHAFT ASSEMBLY FOR 9800.)</u>
31	P-957	<u>SCREW - HEX</u>
32	P-36410	<u>LOCK SPRING</u>
33	P-36543	<u>SPRING - FOR OLD STYLE WATER BOTTLE VALVE.</u>

**DRAWING #19**  
**WATER FOUNTAIN ROLLER, BRACKETS & SUPER AQUAMATIC UNIT**

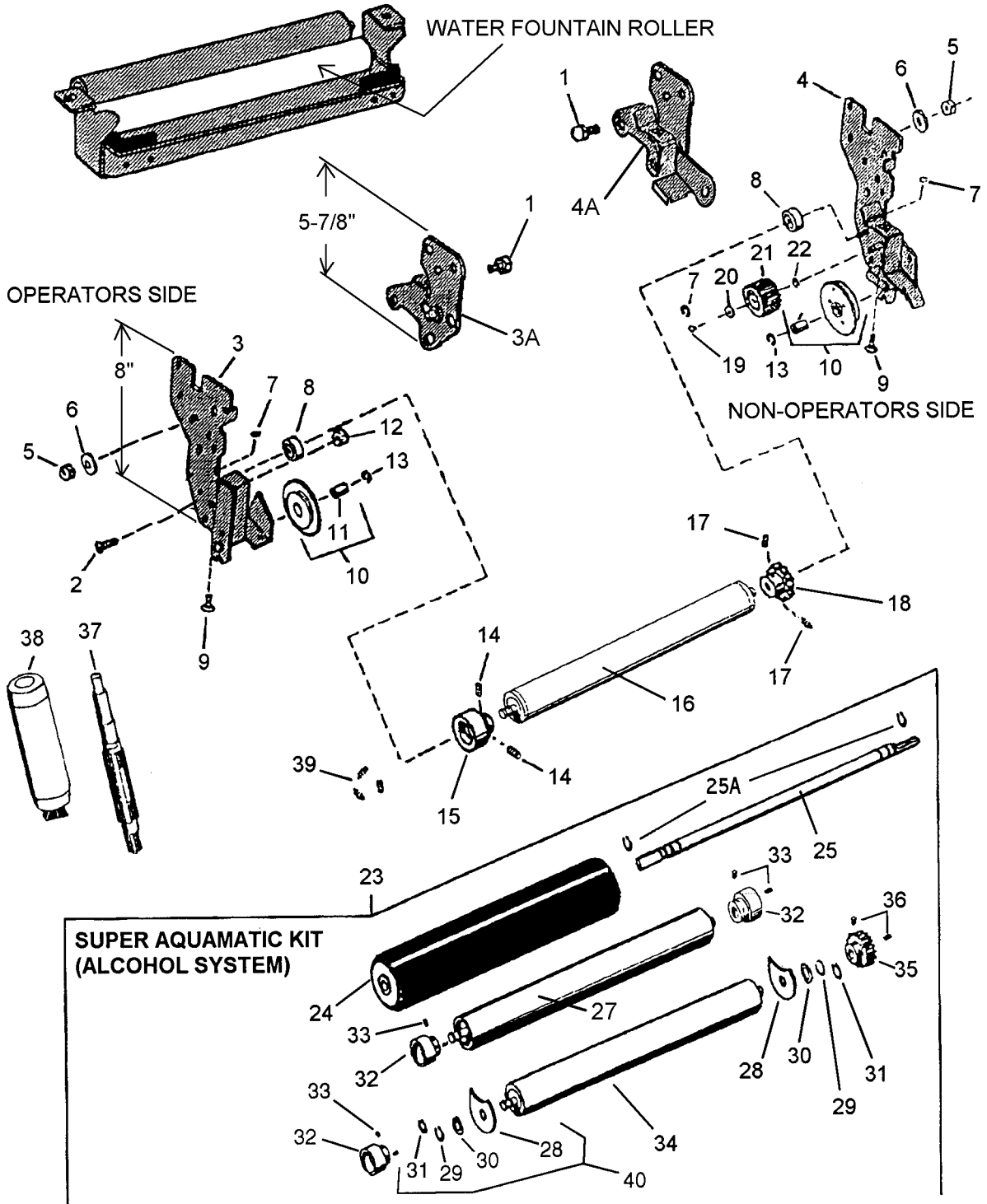

**PAGE #19**  
**WATER FOUNTAIN ROLLER, BRACKETS & SUPER AQUAMATIC UNIT**

KEY #	PART#	DESCRIPTION
1	P-957	<u>SCREW</u>
2	P-277	<u>SCREW</u> - FRAME MOUNTING
3	P-36348	<u>FRAME</u> - NEW DESIGN, MOUNTS TO UPPER SIDE FRAME, OPERATOR SIDE, SEE ITEMS #18 & #25, PAGE 18.
3A	P-36344	<u>FRAME</u> - OLD DESIGN, MOUNTS TO UPPER SIDE FRAME, OPERATOR SIDE, SEE ITEMS #18 & #25, PAGE 18.
4	P-36350	<u>FRAME</u> - NEW DESIGN, MOUNTS TO UPPER SIDE FRAME, NON-OPERATOR SIDE, SEE ITEMS #19 & #25, PAGE
18.		
4A	P-36346	<u>FRAME</u> - OLD DESIGN, MOUNTS TO UPPER SIDE FRAME, NON-OPERATOR SIDE, SEE ITEMS #19 & #25, PAGE
18.		
5	P-479	<u>NUT</u>
6	P-1582	<u>WASHER</u>
7	P-700	<u>RETAINING RING</u> - TROUGH MOUNTING SCREW (P-36356)
8	P-746	<u>BALL BEARING</u> - FITS INTO ITEM #32, THIS PAGE.
9	P-8002	<u>SHOULDER SCREW</u> - TROUGH MOUNTING, SEE ITEMS #4 & #5, PAGE 18.
10	P-36358	<u>GEAR CAM ASSEMBLY</u> - (NEW DESIGN) OPERATES WITH GEAR, ITEM #15, PAGE 16, OR ITEM #46, PAGE 15 & CAM ROLLERS ITEM #15, PAGE 20. SEE ITEM #11, P-824, THIS PAGE
	P-36360	<u>GEAR CAM ASSEMBLY</u> - (OLD DESIGN) HAS HUB ON CAM THAT FITS INTO FRAME) OPERATES WITH GEAR, ITEM #15, PAGE 16, OR ITEM #46, PAGE 15 & CAM ROLLERS, ITEM #15, PAGE 20. SEE ITEM #11, P-825, THIS PAGE
11	P-824	<u>BUSHING</u> - FOR P-36358 - SEE ITEM #37 & #38, THIS PAGE.
	P-825	<u>BUSHING</u> - FOR P-36360
12	P-487	<u>NUT</u>
13	P-670	<u>C-RING</u>
14	P-8	<u>SET SCREW</u>
15	P-36366	<u>BEARING HOUSING</u> - FOR FOUNTAIN ROLLER
16	P-35364	<u>FOUNTAIN ROLLER</u> - SMOOTH COPPER - 350 - 367 - 367A.
	P-36364	<u>FOUNTAIN ROLLER</u> - ROUGH COPPER - 360
	P-36055	<u>FOUNTAIN ROLLER</u> - RUBBER,(ALCOHOL SYSTEM ONLY) - 360
	P-37364	<u>FOUNTAIN ROLLER</u> - ROUGH COPPER - 375 & 9800
	P-37055	<u>FOUNTAIN ROLLER</u> - RUBBER,(ALCOHOL SYSTEM ONLY) - 375 & 9800
17	P-25	<u>SET SCREW</u>
18	P-36370	<u>GEAR</u> - ATTACHES TO & OPERATES WITH IDLER GEAR, ITEM #21, THIS PAGE.
19	P-36372	<u>LOCK SCREW</u> - OBSOLETE. USE P-700 RETAINING RING #7.
19A	P-700	<u>RETAINING RING</u>
20	P-598	<u>WASHER</u>
21	P-36368	<u>IDLER GEAR</u> - OPERATES BETWEEN GEAR, ITEM #13, PAGE 16, OR ITEM #21 PAGE 17, & GEAR, ITEM #18, OR #35, THIS PAGE
22	P-657	<u>SPRING WASHER</u>
23	P-36374	<u>SUPER AQUAMATIC KIT</u> - (THE ALCOHOL SYSTEM) - FOR THE 350 & 360
	P-37374	<u>SUPER AQUAMATIC KIT</u> - (THE ALCOHOL SYSTEM) - FOR THE 375 & 9800
24	P-36059	<u>WAVER ROLLER</u> - 1 EA. - REPLACES ITEM #14, PAGE 21.
	P-37059	<u>WAVER ROLLER</u> - 1 EA. - REPLACES ITEM #14, PAGE 21.
25	P-36378	<u>SHAFT</u> - 1 EA. - UNIVERSAL, FITS ALL MODELS. CONNECTS TO ITEM #4, & #2, PAGE 21.
	P-37378	<u>SHAFT</u> - 1 EA. - UNIVERSAL, FITS ALL MODELS, CONNECTS TO ITEM #4, & #2, PAGE 21.
25A	P-705	<u>RETAINING RING</u>
27	P-36342-S	<u>CHROME DUCTOR ROLLER (SMOOTH)</u> - 350 & 360, 1 EA. - REPLACES ITEM #14, PAGE 18.
	P-36342-R	* <u>CHROME DUSTOR ROLLER (ROUGH SURFACE)</u> - NOT PART OF P-36374 KIT. 350 & 360, 1 EA. REPLACES #14, PAGE 18.
	P-37342-S	<u>CHROME DUCTOR ROLLER (SMOOTH)</u> - 375 & 9800, 1 EA. - REPLACES ITEM #14, PAGE 18.
	P-37342-R	* <u>CHROME DUSTOR ROLLER (ROUGH SURFACE)</u> - NOT PART OF P-36374 KIT. 350 & 360, 1 EA. REPLACES #14, PAGE 18.
28	P-36376	<u>SHIELD</u> - 2 EA.
29	P-617	<u>WASHER</u> - 2 EA.
30	P-658	<u>SPRING WASHER</u> - 2 EA.
31	P-706	<u>RETAINING RING</u> - 2 EA.
32	P-36366	<u>HOUSING</u> - 3 EA. - FITS INTO ITEM #8, THIS PAGE.
33	P-8	<u>SET SCREW</u> - 6 EA.
34	P-36055	<u>RUBBER WATER FOUNTAIN ROLLER</u> - 350 & 360, 1 EA. - REPLACES ITEM #16, THIS PAGE.
	P-37055	<u>RUBBER WATER FOUNTAIN ROLLER</u> - 375 & 9800, 1 EA. - REPLACES ITEM #16, THIS PAGE.
35	P-36370	<u>GEAR</u> - 1 EA. - RUNS ON FOUNTAIN ROLLER, ITEM #21, THIS PAGE.
36	P-25	<u>SET SCREW</u> - 2 EA.
37	P-5952	<u>ADJUSTABLE REAMER</u> - FOR BUSHING P-824, ITEM #11, THIS PAGE.
38	P-1546	<u>HAND REAMER</u>
39	P-36356	<u>SPRING</u> - FOR AQUAMATIC CLUTCH, 355, 365, 366 MODELS ONLY.
40	P-36376-K	<u>HARDWARE REPAIR KIT FOR SUPER AQUAMATIC UNIT</u> - CONSISTS OF 2 OF EA. - ITEM #28, #29, #30, #31.

**DRAWING #20**  
**WATER CONTROL LEVER ASSEMBLY**

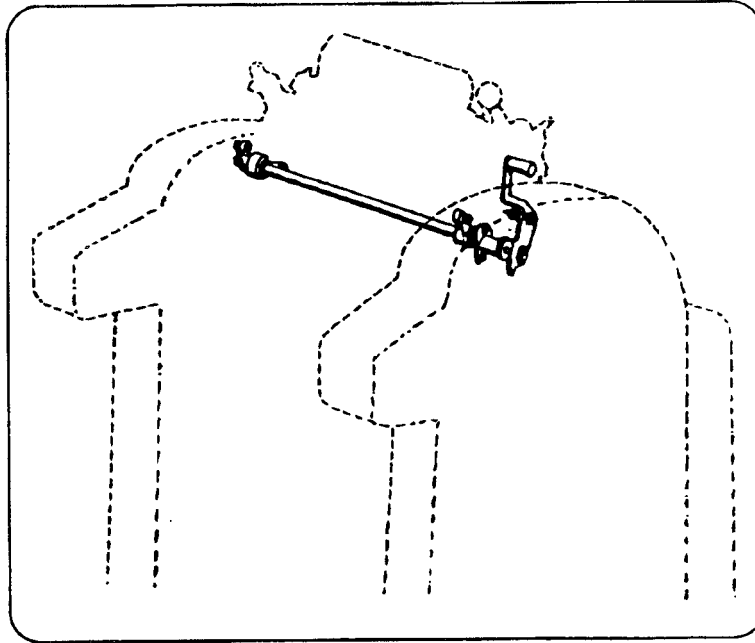

**NON-OPERATORS SIDE**

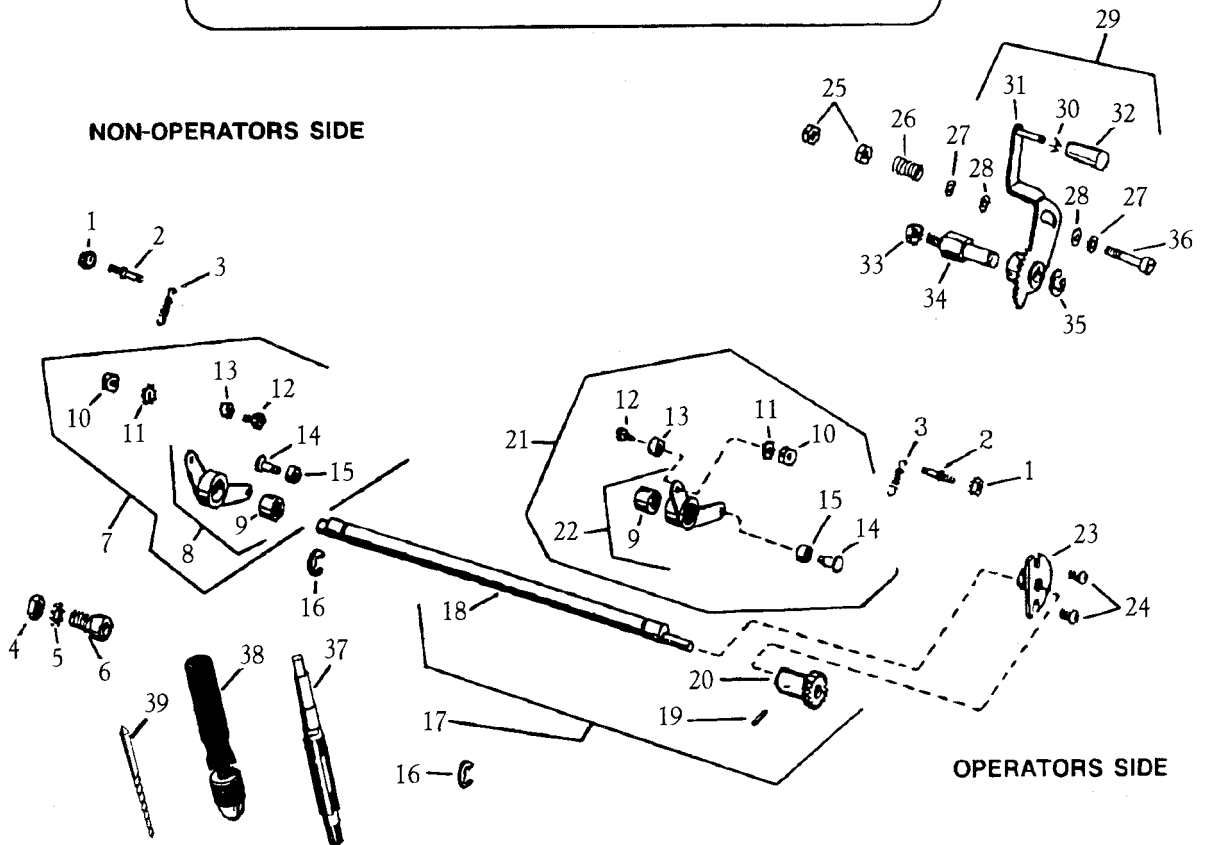

**OPERATORS SIDE**

**PAGE #20**  
**WATER CONTROL LEVER ASSEMBLY**

KEY #	PART#	DESCRIPTION
1	P-471	<u>KEPS NUT</u>
2	P-6015	<u>SPRING ANCHOR</u> - INSIDE UPPER SIDE FRAME.
3	P-36300	<u>SPRING</u> - ATTACHES TO ITEMS #8, & #22, THIS PAGE.
4	P-510	<u>NUT</u>
5	P-639	<u>LOCK WASHER</u>
6	P-36382	<u>ANCHOR STUD</u> - NEW DESIGN FITS 5/8" HOLE IN OUTSIDE FRAME - NON OPERATORS SIDE.
7	P-36400	<u>LEVER ASSEMBLY</u> - NON OPERATOR SIDE, OPERATES ON ITEM #10, PAGE 19.
8	P-36406	<u>LEVER</u> - NON OPERATOR SIDE.
9	P-1244	<u>BUSHING</u> - SEE ITEM #37 & #38, THIS PAGE.
10	P-469	<u>NUT</u>
11	P-633	<u>LOCK WASHER</u>
12	P-8003	<u>ECCENTRIC SHOULDER SCREW</u> - NEW DESIGN, USE TRUCK P-1413.
13	P-1467	<u>ROLLER</u> - OLD DESIGN, OPERATES WITH ITEMS #18, & #19, PAGE 18.
	P-1413	<u>ROLLER</u> - NEW DESIGN, USE WITH STUD P-8003, OPERATES WITH ITEMS #18 & #19, PAGE 18.
14	P-1578	<u>RIVET</u>
15	P-1467	<u>CAM ROLLER</u> - OPERATES WITH CAM, ITEM #10, PAGE 19.
16	P-672	<u>C-RING</u>
17	P-36394	<u>ECCENTRIC SHAFT &amp; PINION ASSEMBLY</u>
	P-37394	<u>ECCENTRIC SHAFT &amp; PINION ASSEMBLY</u>
18	P-36396	<u>ECCENTRIC SHAFT</u> - 350 & 360.
	P-36398	<u>ECCENTRIC SHAFT</u> - 369.
	P-37396	<u>ECCENTRIC SHAFT</u> - 375 & 9800 - NOT SOLD SEPARATELY, USE P-37934, ITEM #17, THIS PAGE.
19	P-421	<u>TAPER PIN</u>
20	P-36404	<u>PINION GEAR</u> - OUTSIDE OF SIDE FRAME. NEED PROPER TOOLS TO INSTALL, ITEMS #38 & #39.
21	P-36384	<u>LEVER ASSEMBLY</u> - OPERATOR SIDE, OPERATES ON ITEM #10, PAGE 19.
22	P-36386	<u>LEVER</u> - OPERATOR SIDE.
23	P-36402	<u>HOUSING BUSHING</u> - OUTSIDE OF SIDE FRAME.
24	P-271	<u>SCREW</u>
25	P-486	<u>NUT</u>
26	P-36408	<u>SPRING</u>
27	P-1614	<u>WASHER</u>
28	P-1522	<u>FIBER WASHER</u>
29	P-36416	<u>LEVER ASSEMBLY</u>
	P-98416	<u>LEVER ASSEMBLY</u>
30	P-36410	<u>LOCK SPRING</u>
31	P-36418	<u>LEVER</u> - 350, 360 & 375.
	NO #	<u>LEVER</u> - NOT SOLD SEPARATELY FOR 9800. USE P-98416 ASSEMBLY, ITEM #29 THIS PAGE.
32	P-36062	<u>HANDLE</u>
33	P-487	<u>NUT</u>
34	P-36420	<u>STUD</u> - OLD DESIGN, S.N. 346873 AND BELOW.
	P-36422	<u>STUD</u> - NEW DESIGN, S.N. 346874 AND ABOVE.
35	P-670	<u>C-RING</u>
36	P-910	<u>SCREW</u> - MOUNTS INTO UPPER SIDE FRAME.
37	P-5951	<u>ADJUSTABLE REAMER</u> - FOR P-1244, BUSHING ITEM #9, THIS PAGE.
38	P-1546	<u>HAND REAMER</u>
39	P-1565	<u>TAPERED REAMER</u>

**DRAWING #21**  
**WATER WAYER (OSCILLATING) ROLLER ASSEMBLY**

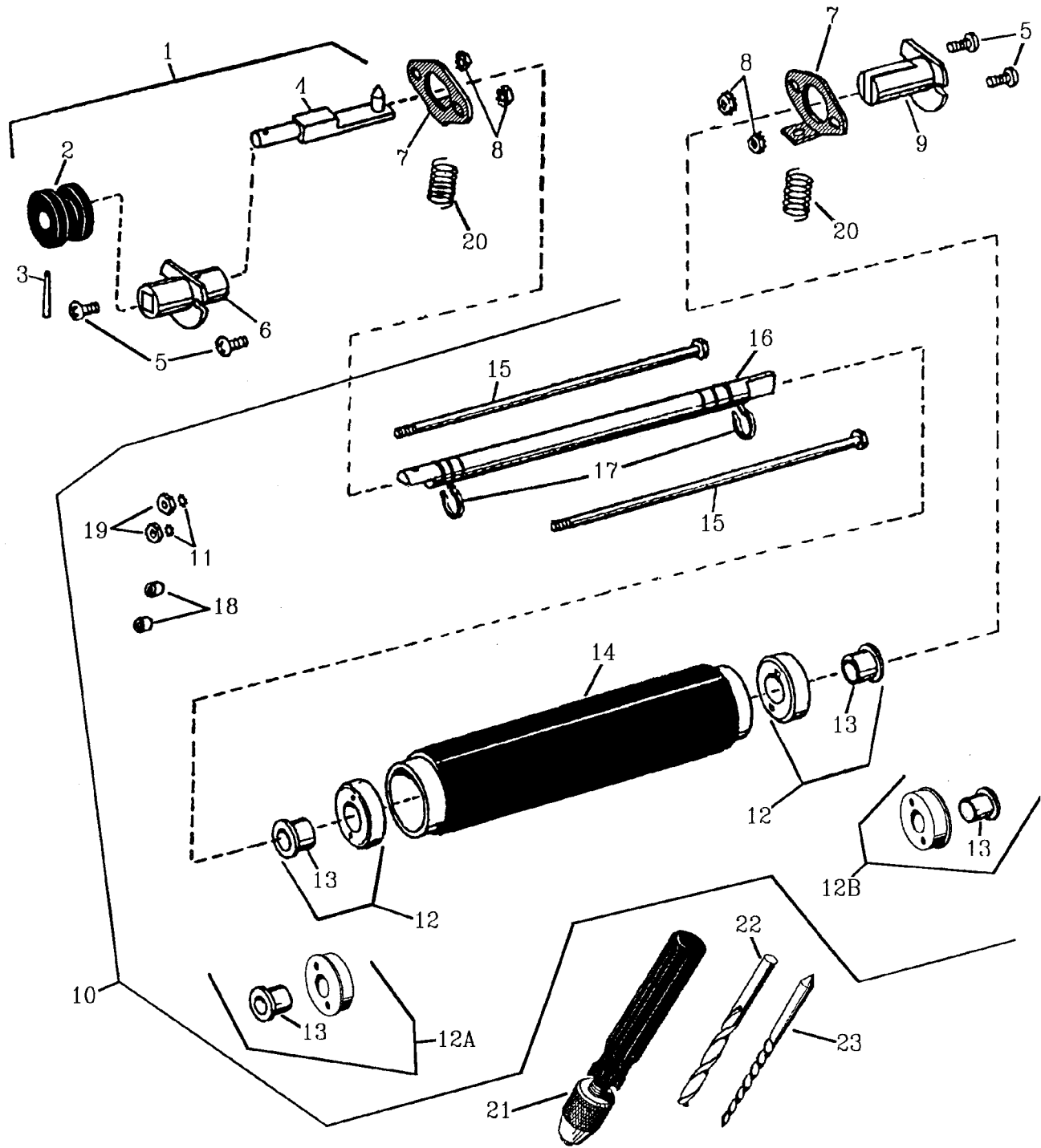

**PAGE #21**  
**WATER WAVER (OSCILLATING) ROLLER ASSEMBLY**

KEY #	PART#	DESCRIPTION
1	P-36426	<u>COUPLE ASSEMBLY</u> - NON-OPERATORS SIDE, OPERATES WITH LEVER, ITEM #28, PAGE 26.
2	P-36428	<u>COUPLE ROLLER</u> - OPERATED BY ITEM #39, PAGE 26. NOT SOLD SEPARATELY - USE P-36426, #1, THIS PAGE.
3	P-433	<u>TAPER PIN</u>
4	P-36430	<u>SHAFT</u> - WAVER ROLLER COUPLE. NOT SOLD SEPARATELY - USE P-36426, #1, THIS PAGE.
5	P-264	<u>PHILLIPS SCREW</u> - FOR OLD STYLE GUIDE BRACKET.
	P-943	<u>HEX HEAD SCREW</u> - FOR NEW STYLE GUIDE BRACKET ONLY, DIA. IS TOO LARGE FOR O.S. BRACKETS.
6	P-36432	<u>GUIDE</u> - HAS 13/64" SHOULDER ON ONE SIDE FOR N.S., FLIP AROUND & USE OTHER SIDE FOR O.S., USES ITEM #5 P-943 & ITEM #8 P-487 BOTH ON THIS PAGE.
7	P-36434	<u>GUIDE BRACKET</u> - WAVER ROLLER
8	P-471	<u>KEPS NUT</u> - USE WITH SCREW, ITEM #5, P-264, THIS PAGE
	P-487	<u>FLANGED LOCK NUT</u> - USE WITH SCREW, ITEM #5, P-943, THIS PAGE
		MEASURE THE HOLE IN YOUR SIDE FRAME IF YOU ARE NOT SURE WHICH STYLE GUIDE YOU NEED.
9	P-36438	<u>GUIDE</u> - OLD STYLE, HAS 13/64" SHOULDER THAT FITS IN SIDE FRAME. OBSOLETE, MUST DRILL OUT FRAME & USE NEW STYLE.
	P-36436	<u>GUIDE</u> - NEW STYLE, HAS 43/64" SHOULDER THAT FITS IN SIDE FRAME.
10	P-350850	<u>WATER OSCILLATING WAVER ROLLER</u> - OUR STYLE. (COMPLETE) 350, HARD RUBBER - ROLLER FACE SURFACE 10-3/8".
	P-360850	<u>WATER OSCILLATING WAVER ROLLER</u> - OUR STYLE. (COMPLETE) 360, HARD RUBBER - ROLLER FACE SURFACE 11-1/4".
	P-370850	<u>WATER OSCILLATING WAVER ROLLER</u> - OUR STYLE. (COMPLETE) 375 & 9800 HARD RUBBER - ROLLER FACE SURFACE 13-1/4".
	P-35085	<u>WATER OSCILLATING WAVER ROLLER</u> - (COMPLETE) 350, NYLON COATED - ROLLER FACE SURFACE 10-3/8".
	P-36085	<u>WATER OSCILLATING WAVER ROLLER</u> - (COMPLETE) 360, NYLON COATED - ROLLER FACE SURFACE 11-1/4".
11	P-635	<u>LOCK WASHER</u>
12	P-36440	<u>END CAP &amp; BUSHING ASSEMBLY</u> - WAVER ROLLER - FOR AB DICKS STYLE ONLY - WORKS WITH ITEM #18 SPECIAL NUT P-36448, AND ITEM #15 THREADED RODS.
12A	P-36453	<u>THREADED END CAP &amp; BUSHING</u> - WAVER ROLLER - FOR OUR STYLE ONLY.
12B	P-36443	<u>PLAIN NON-THREADED END CAP &amp; BUSHING</u> - OUR STYLE. WILL NOT FIT A.B. DICKS.
13	P-1315	<u>BUSHING</u> - USE FOR ITEM #12, P-36440 ONLY.
	P-5841	<u>BUSHING</u> - FOR ITEMS #12A, P-36453 & 12B, P-36443.
14	P-350851	<u>350 WATER OSCILLATING HARD RUBBER SHELL ONLY</u> - 10-3/8" SURFACE, OUR STYLE WILL NOT FIT AB DICKS.
	P-360851	<u>360 WATER OSCILLATING HARD RUBBER SHELL ONLY</u> - 11-1/4" SURFACE. OUR STYLE WILL NOT FIT AB DICKS.
	P-36059	<u>WAVER ROLLER</u> - SOFT RUBBER FOR (ALCOHOL SYSTEMS ONLY). SEE DRAWING #19, ITEM #24 SUPER AQUAMATIC KIT P-36374. INCLUDES BOTH END CAPS.
	P-35450	<u>WAVER ROLLER</u> - NYLON (SHELL ONLY-350). WILL NOT FIT OUR END CAPS. USE WITH END CAPS #12 P-36440.
	P-36450	<u>WAVER ROLLER</u> - NYLON (SHELL ONLY-360). WILL NOT FIT OUR END CAPS. USE WITH ITEM #12 P-36440.
	P-37059	<u>WAVER ROLLER</u> - SOFT RUBBER FOR (ALCOHOL SYSTEMS ONLY). SEE DRAWING #19, ITEM #24 SUPER AQUAMATIC KIT P-37374. INCLUDES BOTH END CAPS.
	P-37450	<u>WAVER ROLLER</u> - NYLON "SHELL ONLY" (375/9800). WILL NOT FIT OUR END CAPS. USE WITH ITEM #12 P-36440.
15	P-35444	<u>WAVER ROLLER SCREW</u> - (350) 11-1/2" LONG - FOR (OLD STYLE) ROLLER (350 OR 360) SEE NOTE.
	P-35446	<u>WAVER ROLLER SCREW</u> - (350) 10-1/2" LONG FOR P-35085.
	P-36444	<u>WAVER ROLLER SCREW</u> - (360) 10-1/2" LONG FOR P-36085.
	P-36433	<u>WAVER ROLLER SCREW</u> - (350 & 360) OUR STYLE 11" LONG - FOR P-36085 & P-350850.
	P-37444	<u>WAVER ROLLER SCREW</u> - (375/9800) 12 1/2" LONG. USE WITH ITEM #18 P-36448 & ITEM #12 P-36440.
16	P-36378	<u>WAVER ROLLER SHAFT</u> - 350, 360 & 369.
	P-37378	<u>WAVER ROLLER SHAFT</u> - (375/9800 OLD STYLE)
	P-98378	<u>WAVER ROLLER SHAFT</u> - (9800 NEW STYLE)
17	P-705	<u>RETAINING RING</u>
18	P-36448	<u>SPECIAL NUT</u> - FOR P-35446 & P-36444 SCREWS, ITEM #15.
19	P-478	<u>NUT</u> - FOR P-35444 SCREWS ONLY, ITEM 15.
20	P-36413	<u>COMPRESSION SPRING</u> - (RED) FITS BETWEEN GUIDE BRACKET, ITEM #7, THIS PAGE & BLOCKS ITEM #11 & #19, PAGE 22.
21	P-1546	<u>HAND REAMER</u>
22	P-1592	<u>DRILL BIT</u>
23	P-1547	<u>REAMER BIT</u>
		<b>NOTE:</b> - (OLD STYLE) WAVER ROLLER IS NOT AVAILABLE. USE (NEW STYLE) P-35085 FOR 350, OR P-36085 FOR 360, OR USE P-350850 FOR 350, OR USE P-360850 FOR 360. (SCREWS ARE SOLD SEPARATELY IF YOU HAVE OLD STYLE ROLLER)

**DRAWING #22**  
**UPPER FORM ROLLER & MANUAL CONTROL NIGHT LATCH**

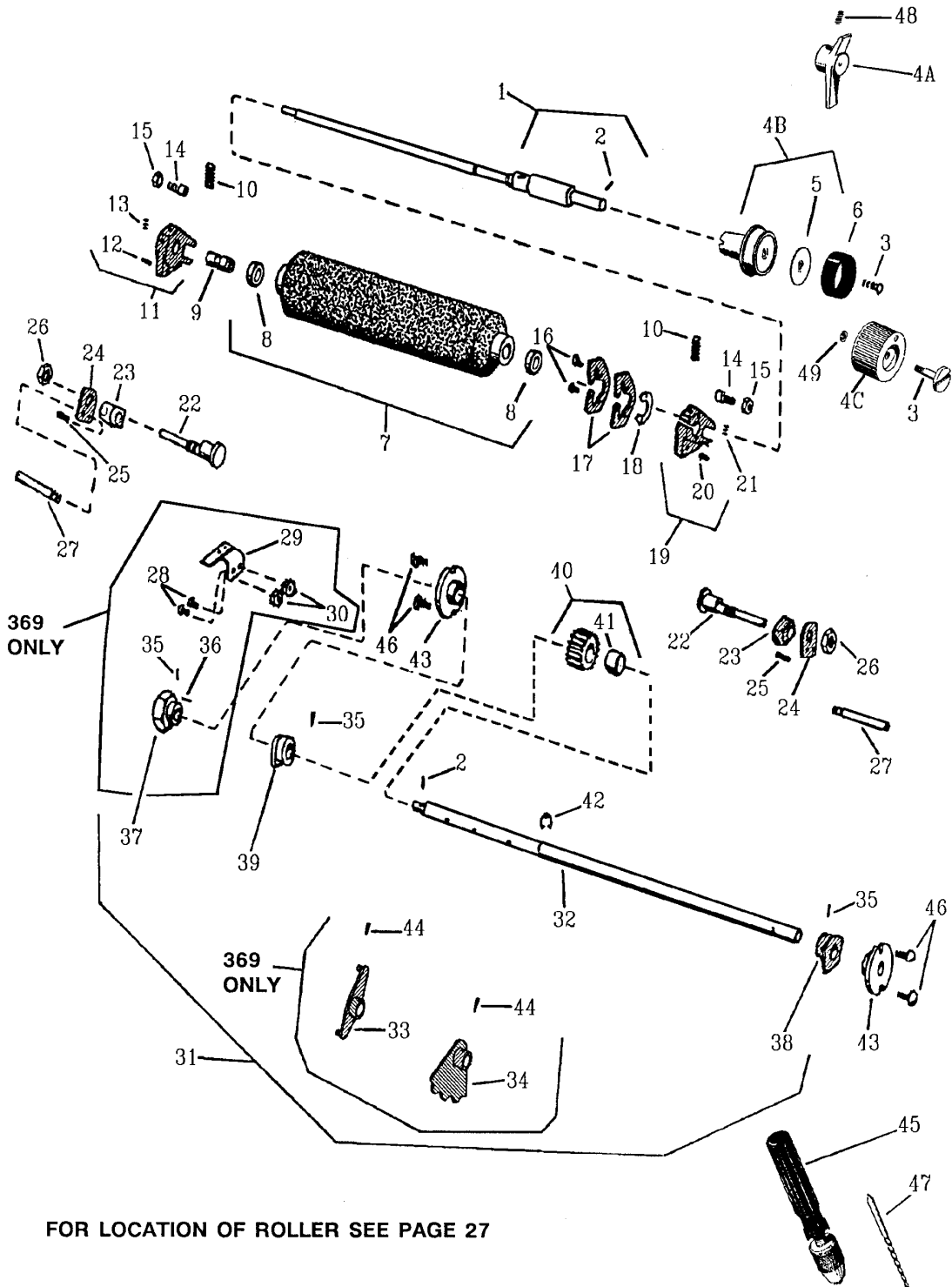

FOR LOCATION OF ROLLER SEE PAGE 27



**PAGE #22**  
**UPPER FORM ROLLER & MANUAL CONTROL NIGHT LATCH**

KEY #	PART#	DESCRIPTION
1	P-36401	<u>FORM ROLL SHAFT</u> - 350 & 360.
	P-37401	<u>FORM ROLL SHAFT</u> - 375 & 9800.
2	P-380	<u>ROLL PIN</u>
3	P-300	<u>SCREW</u>
	P-8045	<u>SCREW</u> - 9800 ONLY.
4A	OBSOLETE	<u>KNOB</u> - WITH SET SCREW (SER. NO. 235601 & BELOW) USE P-36405 ITEM #4B, THIS PAGE.
4B	P-36405	<u>FORM ROLL KNOB</u> - INCLUDES P-36407. SEE ITEM 55, PAGE 47.
4C	P-98031	<u>KNOB</u> - MOST COMMONLY USED ON 9800.
5	P-36407	<u>INSERT DISC</u>
6	P-36399	<u>HAND GRIP TIRE</u>
7	P-35010	<u>FORM ROLLER</u> - 350- LOCATED UNDERNEATH WAVER ROLLER.
	P-36010	<u>FORM ROLLER</u> - 360- LOCATED UNDERNEATH WAVER ROLLER.
	P-37010	<u>FORM ROLLER</u> - 375 & 9800 - LOCATED UNDERNEATH WAVER ROLLER.
8	P-742	<u>BALL BEARING</u>
9	P-36411	<u>SLEEVE BEARING</u>
10	P-36413	<u>COMPRESSION SPRING</u> - (RED) FITS BETWEEN BLOCKS, #11 & #19 ON THIS PAGE & BRACKET #7, PAGE 21.
11	P-36415	<u>FORM ROLL BLOCK</u> - MOUNTS TO SIDE FRAME ON NON-OPERATORS SIDE.
12	P-517	<u>SPIRAL PIN</u>
13	P-11	<u>SET SCREW</u>
14	P-36417	<u>ECCENTRIC STOP SCREW</u> - OBSOLETE - FOR 2" DIA. ROLLERS.
15	P-487	<u>HEX NUT</u>
16	P-248	<u>SCREW</u>
17	P-36419	<u>LEVER</u> - OPERATOR SIDE (REQUIRES 2)
18	P-36421	<u>LEVER STOP RING</u>
19	P-36423	<u>FORM ROLL BLOCK</u> - MOUNTS TO SIDE FRAME ON OPERATORS SIDE.
20	P-517	<u>SPIRAL PIN</u>
21	P-851	<u>SET SCREW</u>
22	P-36425	<u>ECCENTRIC ADJUSTING SCREW</u> - (ROUND HEAD, 1/2" DIA. SHOULDER, 3-13/16 OAL.) MUST HAVE BLOCK, ITEM #23 TO USE THIS OLD STYLE, GOES THRU BLOCKS ITEMS #11 & #19, FOR STANDARD NIGHT LATCH.
	P-36427	<u>ECCENTRIC ADJUSTING SCREW</u> - (HEX HEAD, 5/8" DIA. SHOULDER, 2-11/16" OAL.) NEW STYLE DOES NOT USE BLOCK, ITEM #23, GOES THRU BLOCKS ITEMS #11 & #19, FOR SINGLE LEVER CONTROL.
22A	P-379	<u>ROLL PIN</u> - FOR P-36427 ONLY.
23	P-36429	<u>BLOCK</u> - OLD STYLE FOR P-36425, ITEM #22, THIS PAGE.
24	P-36431	<u>FORM ROLL ADJUSTING LOCKS</u>
25	P-388	<u>ROLL PIN</u>
26	P-526	<u>ELASTIC LOCK NUT</u>
27	P-7000	<u>LOCKING SCREW</u>
28	P-263	<u>SCREW</u> - 369 ONLY.
29	P-36435	<u>LOCK SPRING</u> - WORKS WITH ITEM #37, MOUNTS TO SIDE FRAME ON OPERATORS SIDE. (369 ONLY)
30	P-471	<u>KEPS NUT</u> - 369 ONLY.
31	P-36437	<u>SHAFT ASSEMBLY</u> - 350 OR 360 MANUAL CONTROL (ITEMS #32, #35, & #39)
	P-36439	<u>SHAFT ASSEMBLY</u> - FOR 369 ONLY (ITEMS #32, #33, #34, & #44)
32	P-36441	<u>SHAFT</u>
33	P-36469	<u>ARM</u> - FOR 369 ONLY.
34	P-36447	<u>NOTCHED CAM</u> - 369 ONLY, (IN PLACE OF P-36445, ITEM 37)
35	P-424	<u>TAPER PIN</u>
36	P-383	<u>ROLL PIN</u>
37	P-36445	<u>HEX CAM</u> - 350 & 360 ONLY, WORKS WITH ITEM #29.
38	P-36465	<u>CAM</u> - NON OPERATOR SIDE, MUST TAPER REAM TO FIT, SEE REAMER #P-1546, & REAMER BIT P-1547
39	P-36451	<u>CAM</u> - OPERATOR SIDE, MUST TAPER REAM TO FIT, SEE REAMER #P-1546 & REAMER BIT #P-1547.
40	P-36446	<u>BRASS IDLER GEAR</u> - SEE NOTE.
	P-36455	<u>NYLON IDLER GEAR</u> - SEE NOTE.
	P-36457	<u>STEEL IDLER GEAR</u> - SEE NOTE.
41	P-1223	<u>BUSHING</u>
42	P-672	<u>C-RING</u>
43	P-36449	<u>HOUSING</u>
44	P-349	<u>SPIRAL PIN</u> - FOR NOTCHED CAM.
45	P-1546	<u>HAND REAMER</u>
46	P-271	<u>SCREW</u>
47	P-1547	<u>REAMER BIT</u>
48	P-10	<u>SET SCREW</u>
49	P-1495	<u>O-RING</u>
		<b>NOTE:</b> OPERATES BETWEEN GEAR ON ROLLER, ITEM #1 PAGE 28, & ITEMS #10, #10A, #10B, #10C, PAGE 25. THIS GEAR IS USED TWICE, SEE ITEM #30 PAGE 25. NON-OPERATOR SIDE.

**DRAWING #23**  
**LOWER FORM ROLLER & SINGLE LEVER CONTROL**

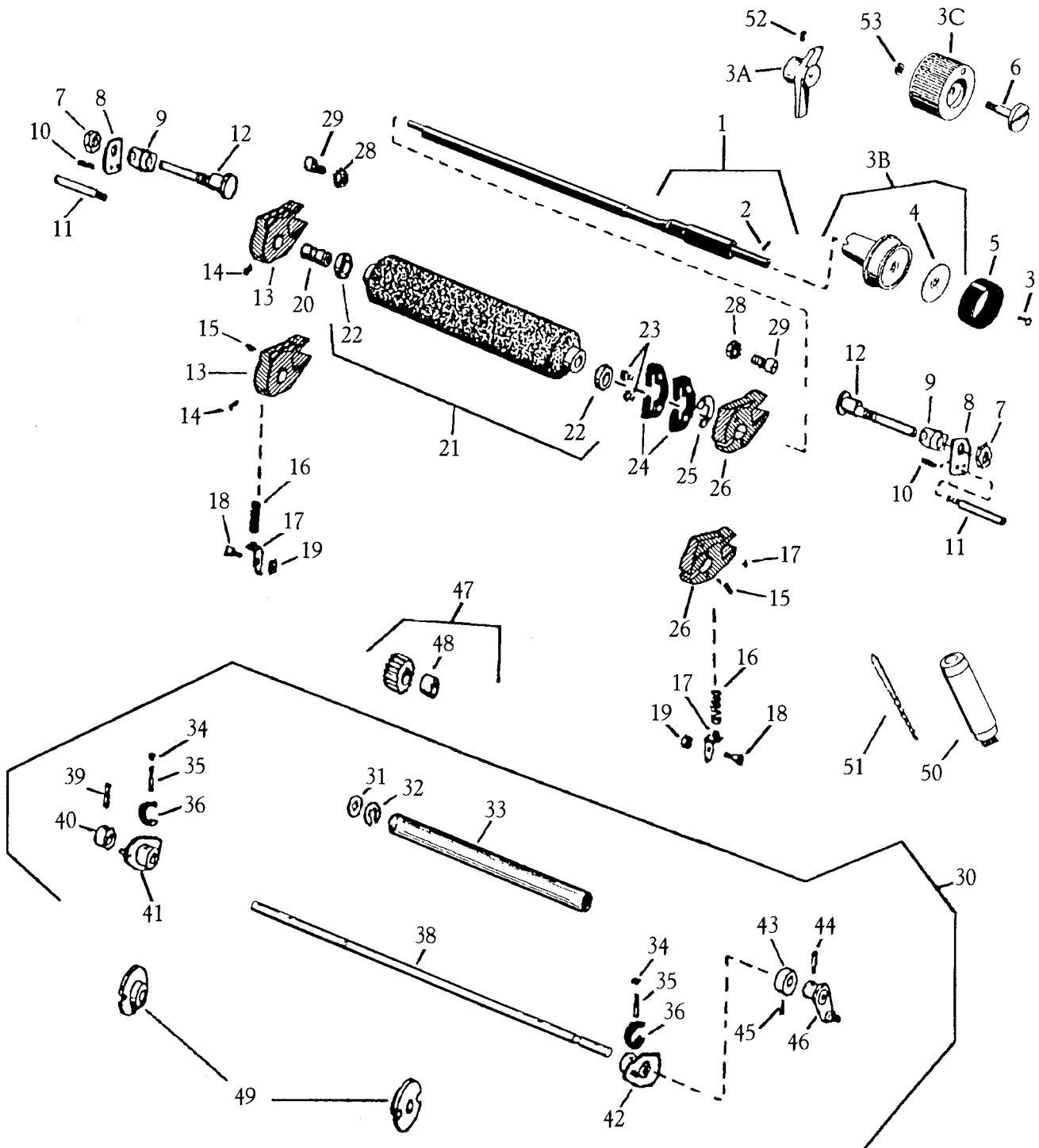

**FOR LOCATION OF ROLLER SEE PAGE #27.**

**PAGE #23**  
**LOWER FORM ROLLER & SINGLE LEVER CONTROL**

KEY #	PART#	DESCRIPTION
1	P-36401	<u>FORM ROLL SHAFT</u> - 350 & 360.
	P-37401	<u>FORM ROLL SHAFT</u> - 375 & 9800.
2	P-380	<u>ROLL PIN</u>
3A	OBSOLETE	<u>KNOB</u> - WITH SET SCREW (SER. NO. 235601 & BELOW) USE P-36405 ITEM #3B, THIS PAGE.
3B	P-36405	<u>FORM ROLL KNOB</u> - SEE ITEM #55, PAGE 47.
3C	P-98031	<u>FORM ROLL KNOB</u> - 9800, SEE ITEM #55, PAGE 47.
4	P-36407	<u>INSERT DISC</u>
5	P-36399	<u>HAND GRIP TIRE</u>
6	P-300	<u>SCREW</u>
	P-8045	<u>SCREW</u> - FOR 9800.
7	P-526	<u>ELASTIC LOCK NUT</u>
8	P-36431	<u>FORM ROLL ADJUSTING LOCKS</u>
	P-98431	<u>FORM ROLL ADJUSTING LOCK</u> - 9800 ONLY. COMES WITH PIN, PIN IS NOT SOLD SEPARATELY.
9	P-36429	<u>BLOCK</u> - (OLD STYLE) FOR P-36425 ITEM #12, THIS PAGE.
10	P-388	<u>ROLL PIN</u>
11	P-7000	<u>LOCKING SCREW</u>
12	P-36427	<u>ECCENTRIC ADJUSTING SCREW</u> - (NEW STYLE - 2 PIECE) USED WITHOUT BLOCK, ITEM #9, THIS PAGE.
	P-36425	<u>ECCENTRIC ADJUSTING SCREW</u> - (OLD STYLE - 1 PIECE) USES BLOCK P-36429, ITEM #9, THIS PAGE.
12A	P-379	<u>ROLL PIN</u> - FOR NEW STYLE P-36427 ONLY.
13	P-36471	<u>FORM ROLL BLOCK</u> - FOR 2" DIA. FORM ROLLER, MOUNTS TO SIDE FRAME ON N.O.S.
	P-36473	<u>FORM ROLL BLOCK</u> - FOR 2 1/2" DIA. FORM ROLLER (SINGLE LEVER CONTROL) MOUNTS TO SIDE FRAME ON N.O.S.
14	P-11	<u>SET SCREW</u>
15	P-348	<u>SPIRAL PIN</u>
16	P-36475	<u>SPRING</u> - USE WITH P-36471 (ITEM 13) FOR 2" DIA. ROLLER BLOCKS.
	P-36477	<u>SPRING</u> - USE WITH P-36473 (ITEM 13) FOR 2 1/2" DIA. ROLLER BLOCKS.
17	P-36479	<u>SPRING ANCHOR</u> - FOR 2" LOWER FORM ROLLERS.
	P-36481	<u>SPRING ANCHOR L.H.</u> - FOR 2 1/2" DIA. FORM ROLLER.
	P-36483	<u>SPRING ANCHOR R.H.</u> - FOR 2 1/2" DIA. FORM ROLLER.
	P-98479	<u>SPRING ANCHOR</u> - FOR 2" LOWER FORM ROLLERS - OPERATOR SIDE.
	P-98481	<u>SPRING ANCHOR L.H.</u> - FOR 2 1/2" DIA. FORM ROLLER - NON-OPERATOR SIDE.
18	P-8006	<u>SHOULDER SCREW</u>
19	P-487	<u>LOCK NUT</u>
20	P-36411	<u>SLEEVE BEARING</u>
21	P-35010	<u>FORM ROLLER</u> - 2" DIAMETER 350 ONLY.
	P-35011	<u>FORM ROLLER</u> - 2 1/2" DIAMETER 350, SINGLE LEVER CONTROL ONLY.
	P-36010	<u>FORM ROLLER</u> - 2" DIAMETER 360 ONLY.
	P-36011	<u>FORM ROLLER</u> - 2 1/2" DIAMETER, 360 SINGLE LEVER CONTROL ONLY.
	P-37011	<u>FORM ROLLER</u> - 2 1/2" DIAMETER, FOR 375 & 9800.
22	P-742	<u>BALL BEARING</u>
23	P-248	<u>SCREW</u>
24	P-36419	<u>LEVER LOCKS</u>
25	P-36421	<u>LEVER STOP RING</u>
26	P-36489	<u>FORM ROLL BLOCK</u> - FOR 2" DIAMETER ROLLERS, MOUNTS TO SIDE FRAME ON OPERATORS SIDE.
	P-36491	<u>FORM ROLL BLOCK</u> - FOR 2 1/2" DIAMETER ROLLERS, MOUNTS TO SIDE FRAME ON OPERATORS SIDE.
27	P-851	<u>SET SCREW</u>
28	P-487	<u>KEPS NUT</u>
29	P-36417	<u>ECCENTRIC STOP SCREW</u> - OBSOLETE.
30	P-36497	<u>SINGLE LEVER SHAFT ASSEMBLY</u> - LOCATED BETWEEN UPPER & LOWER FORM ROLLERS.
	P-37497	<u>SINGLE LEVER SHAFT ASSEMBLY</u> - LOCATED BETWEEN UPPER & LOWER FORM ROLLERS.
31	P-613	<u>WASHER</u>
32	P-687	<u>C-RING</u>
33	P-36509	<u>PLASTIC CLEANING TUBE</u>
	P-37509	<u>PLASTIC CLEANING TUBE</u>
34	P-661	<u>RETAINING RING</u>
35	P-36493	<u>DROP PIN</u>
36	P-36495	<u>RETAINER C-CLIP</u>
38	P-36499	<u>SHAFT</u>
	P-37499	<u>SHAFT</u>
39	P-382	<u>ROLL PIN</u>
40	P-739	<u>COLLAR</u>
41	P-36623	<u>CAM</u> - NON OPERATOR SIDE.
42	P-36503	<u>CAM</u> - OPERATOR SIDE.
43	P-747	<u>ECCENTRIC COLLAR</u>
44	P-424	<u>TAPER PIN</u>
45	P-8	<u>SET SCREW</u>
46	P-36505	<u>LEVER</u> - MUST HAVE HAND REAMER #P-1546 & REAMER BIT #P-1547 TO INSTALL. CONNECTS TO LINK #22, PAGE 37.
47	P-36446	<u>BRASS IDLER GEAR</u> - OPERATES WITH GEAR #44 PAGE 15, #13, PAGE 16 & GEAR #10,10A,10B,10C, PAGE 25.
	P-36455	<u>NYLON IDLER GEAR</u> - OPERATES WITH GEAR #44 PAGE 15, #13, PAGE 16 & GEAR #10,10A,10B,10C, PAGE 25.
	P-36457	<u>STEEL IDLER GEAR</u> - OPERATES WITH GEAR #44 PAGE 15, #13, PAGE 16 & GEAR #10,10A,10B,10C, PAGE 25.
48	P-1223	<u>BUSHING</u>
49	P-36449	<u>HOUSING</u> - FOR SINGLE LEVER SHAFT ASSEMBLY (NOT INCLUDED WITH ASSEMBLY)
50	P-1546	<u>HAND REAMER</u>
51	P-1547	<u>REAMER BIT</u>
52	P-10	<u>SET SCREW</u>
53	P-1495	<u>O-RING</u>

DRAWING #24A  
FORM 3 - (SECTION 1)

THIRD  
FORM  
ROLLER

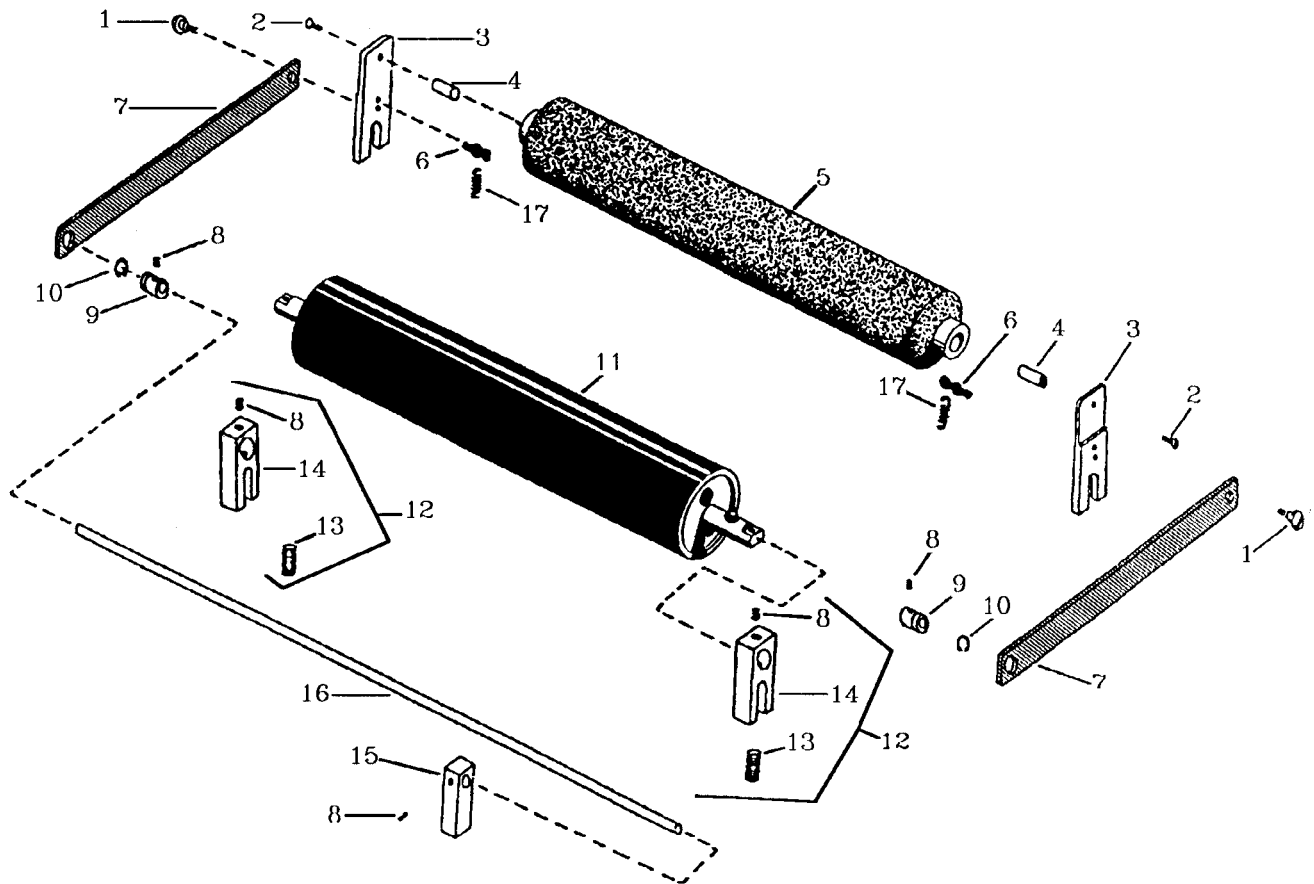
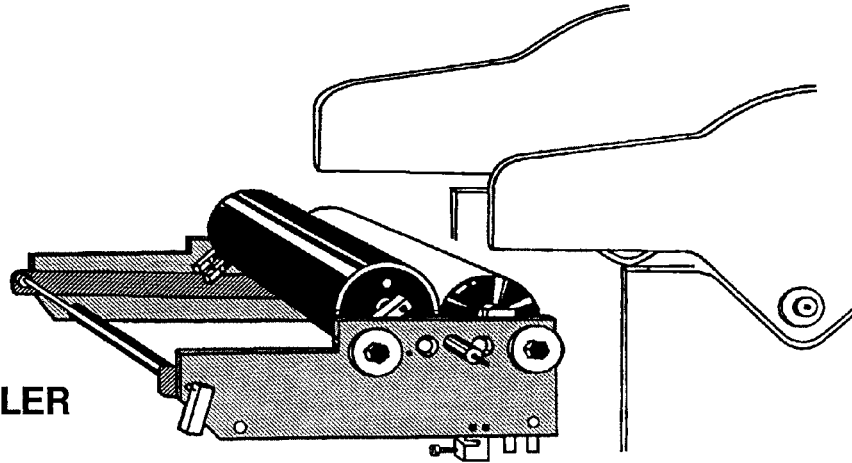

**PAGE #24A**  
**FORM 3 - (SECTION 1)**

KEY #	PART#	DESCRIPTION
1	P-8007	<u>SHOULDER SCREW</u>
2	P-124	<u>SCREW</u>
3	P-36627	<u>PIVOT BRACKET</u> - BRACKET SLIDES INTO ITEM #12 PAGE 24B.
4	P-36511	<u>ROLLER BEARING STUD</u> - 350 (2-1/2" DIA).
5	P-35011	<u>FORM ROLLER</u> - 350 (2-1/2" DIA).
	P-36011	<u>FORM ROLLER</u> - 360 (2-1/2" DIA).
	P-37011	<u>FORM ROLLER</u> - 375 & 9800 (2-1/2" DIA).
6	P-6007	<u>SPRING ANCHOR</u>
7	P-36515	<u>PIVOT LINK</u>
8	P-8	<u>SET SCREW</u>
9	P-36517	<u>ECCENTRIC BEARING</u>
10	P-705	<u>RETAINING RING</u>
11	P-350820	<u>OSCILLATING ROLLER</u> - 350 COMPLETE.
	P-360820	<u>OSCILLATING ROLLER</u> - 360 COMPLETE.
	P-370820	<u>OSCILLATING ROLLER</u> - 375 & 9800 COMPLETE.
12	P-36522	<u>OSCILLATING ROLLER BRACKET ASSEMBLY</u> - ALSO INCLUDES SET SCREW, ITEM #8 THIS PAGE.
13	P-361740	<u>SPRING</u>
14	P-36521	<u>ROLLER BRACKET</u>
15	P-36531	<u>ON &amp; OFF OPERATING LEVER</u>
16	P-36525	<u>ON &amp; OFF ROD</u> - 350 & 360.
	P-37525	<u>ON &amp; OFF ROD</u> - 375 & 9800.
17	P-36549	<u>SPRING</u> - CONNECTS TO ITEM #13 PAGE 24B.

**DRAWING #24B**  
**FORM 3 - (SECTION 2)**

**THIRD  
 FORM  
 ROLLER**

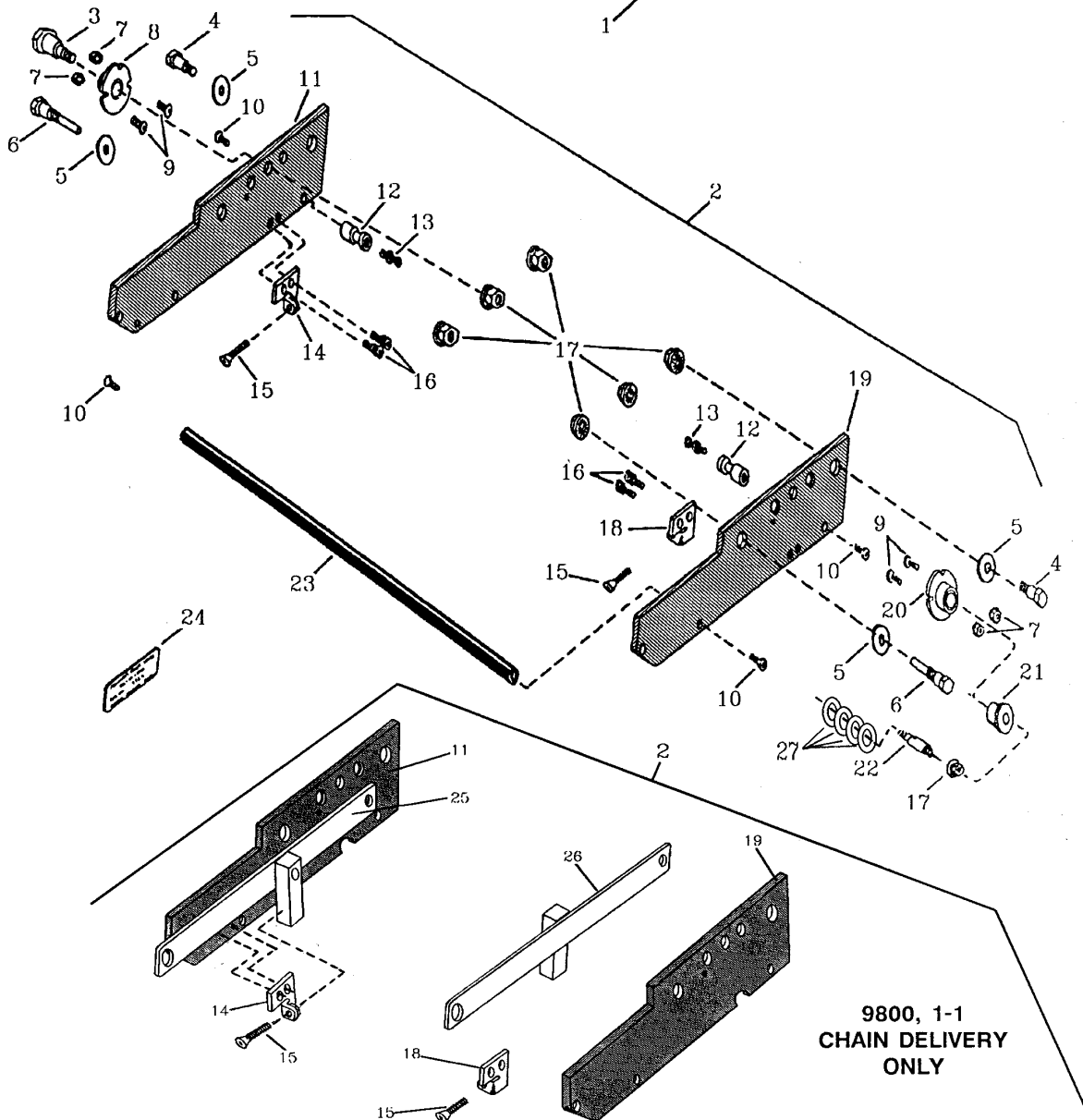
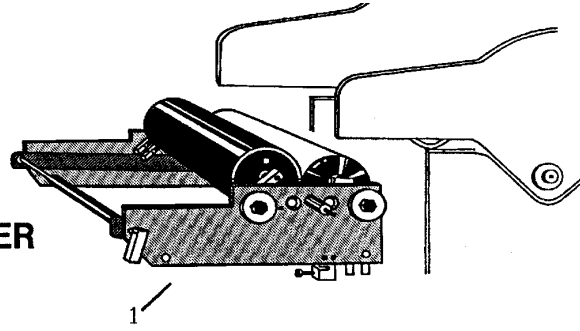

**9800, 1-1  
 CHAIN DELIVERY  
 ONLY**

**PAGE 24B**  
**FORM 3 - (SECTION 2)**

KEY #	PART#	DESCRIPTION
1	P-35533	<u>350 FORM III ASSEMBLY COMPLETE</u>
	P-36533	<u>360 FORM III ASSEMBLY COMPLETE</u>
	P-37533	<u>375 &amp; 9800 STANDARD FORM III COMPLETE</u>
	P-98533	<u>9800, 1-1 FORM III COMPLETE</u>
2	P-35541	<u>350 FORM ROLL KIT</u> - INCLUDES ITEMS ON PAGE 24A & 24B EXCEPT FOR ITEMS #5 & #11.
	P-36541	<u>360 FORM ROLL KIT</u> - INCLUDES ITEMS ON PAGE 24A & 24B EXCEPT FOR ITEMS #5 & #11.
	P-37541	<u>375 &amp; 9800 STANDARD FORM ROLL KIT</u> - INCLUDES ITEMS ON PAGE 24A & 24B EXCEPT FOR ITEMS #5 & #11.
	P-98541	<u>9800, 1-1 FORM ROLL KIT</u> - INCLUDES ITEMS ON PAGE 24A & 24B EXCEPT FOR ITEMS #5 & #11.
3	P-36551	<u>STUD</u> - THIS STUD IS ALREADY ON YOUR PRESS AND IS NOT PART OF ASSEMBLY KIT.
4	P-36553	<u>STUD</u>
5	P-620	<u>WASHER</u>
6	P-36555	<u>ANCHOR STUD</u>
7	P-471	<u>KEPS NUT</u> - NOT PART OF KIT.
8	P-36557	<u>HOUSING</u> - NOT PART OF KIT, SEE ITEM #16 PAGE 46. FITS INTO YOUR FRAME.
8A	P-1261	<u>BUSHING</u>
9	P-263	<u>SCREW</u> - NOT PART OF KIT.
10	P-124	<u>SCREW</u>
11	P-36559	<u>FORM ROLL BRACKET</u> - NON-OPERATORS SIDE.
	P-98559	<u>FORM ROLL BRACKET</u> - NON-OPERATORS SIDE. 9800, 1-1 CHAIN DELIVERY ONLY.
12	P-36561	<u>BRACKET ANCHOR</u> - ITEM #3 PAGE 24A SLIDES INTO THIS BRACKET ANCHOR.
13	P-6007	<u>SPRING ANCHOR</u> - SEE ITEM #17 PAGE 24A.
14	P-36513	<u>ADJUSTING BRACKET</u> - NON-OPERATORS SIDE.
15	P-302	<u>SCREW</u>
16	P-43	<u>SCREW</u>
17	P-505	<u>FLANGED LOCKNUT</u>
18	P-36563	<u>ADJUSTING BRACKET</u> - OPERATORS SIDE.
19	P-36565	<u>FORM ROLL BRACKET</u> - OPERATORS SIDE.
	P-98565	<u>FORM ROLL BRACKET</u> - OPERATORS SIDE. 9800, 1-1 CHAIN DELIVERY ONLY.
20	P-36567	<u>ECCENTRIC HOUSING</u> - THIS HOUSING IS ALREADY ON YOUR PRESS & IS NOT PART OF FORM III. <i>FITS INTO FRAME.</i>
	P-36629	<u>ECCENTRIC HOUSING</u> - 369 S/N 232724 & ABOVE. THIS HOUSING IS ALREADY ON YOUR PRESS & IS NOT PART OF FORM III. <i>FITS INTO FRAME.</i>
21	P-1341	<u>ECCENTRIC BUSHING</u> - BRASS INSERT INTO ITEM #20. THIS BUSHING IS ALREADY ON YOUR PRESS & IS NOT PART OF FORM III.
	P-5809	<u>ECCENTRIC BUSHING</u> - (HEX FLANGE) BRASS INSERT INTO ITEM #20. THIS BUSHING IS ALREADY ON YOUR PRESS & IS NOT PART OF FORM III.
22	P-36571	<u>INSERT STUD</u>
23	P-36573	<u>TIE BAR</u> - 350 & 360.
	P-37541	<u>TIE BAR</u> - 375 & 9800.
24	P-36579	<u>PATENT PLATE</u> - SOLD ONLY WITH ASSEMBLY.
25	P-98515	<u>PIVOT LINK ASSEMBLY</u> - NON-OPERATORS SIDE. 9800, 1-1 CHAIN DELIVERY ONLY.
26	P-98531	<u>PIVOT LINK ASSEMBLY</u> - OPERATORS SIDE. 9800, 1-1 CHAIN DELIVERY ONLY.
27	P-611	<u>WASHER</u>





**PAGE 25**  
**INK OSCILLATOR ROLLER (GEARED)**

KEY #	PART#	DESCRIPTION
1	P-870	<u>SET SCREW</u>
2	P-350	<u>SPIRAL PIN</u> - FOR SYNTAC ROLLERS ONLY
	P-432	<u>TAPER PIN</u> - FOR RELACEMENT OF PIN ONLY
3	P-36507	<u>COUPLING</u> - OPERATES WITH CAM 30, PAGE 26.
4	P-36498	<u>BUSHING ASSEMBLY SLIDE</u>
5	P-263	<u>SCREW</u>
6	P-36496	<u>BUSHING ASSEMBLY</u>
7	P-1221	<u>BUSHING</u>
8	P-471	<u>KEPS NUT</u>
9	P-35510	<u>SHAFT ASSEMBLY</u> - 350
	P-36510	<u>SHAFT ASSEMBLY</u> - 360
	P-37510	<u>SHAFT ASSEMBLY</u> - 375 & 9800
10	P-35518	<u>GEAR</u> - (350 NEW DESIGN, WITH 3 SCREWS) OPERATES WITH GEAR #47, PAGE 23 & GEAR #30, THIS PAGE. SEE NOTE #1. NEED END CAP ITEM #17 FOR MOUNTING P-36526.
10A	P-35514	<u>GEAR</u> - (350 OLD DESIGN, WITH 2 SCREWS) OPERATES WITH GEAR #47, PAGE 23 & GEAR #30, THIS PAGE. SEE NOTE #1. FITS DIRECTLY INTO ROLLER, NEEDS NO END CAP.
10B	P-36520	<u>GEAR</u> - (360 AND 369 NEW DESIGN, WITH 3 SCREWS) OPERATES WITH GEAR #47, PAGE 23 & GEAR #30, THIS PAGE. SEE NOTE #1. NEED END CAP FOR MOUNTING P-36526. NEED END CAP FOR MOUNTING - P-36526
10C	P-36516	<u>GEAR</u> - (360 OLD DESIGN, WITH 2 SCREWS) OPERATES WITH GEAR #47, PAGE 23 & GEAR #30, THIS PAGE. SEE NOTE #1. FITS DIRECTLY INTO ROLLER, NEEDS NO END CAP.
13	P-36524	<u>GEAR</u> - OPERATES WITH GEAR #18, PAGE 28.
14	P-36512	<u>WAVER ROLLER SHAFT</u> - 350, 360 (PIN NEEDS TO BE REPLACED WITH P-436 TAPER PIN IF CUST. HAS ORIGINAL SHAFT.)
	P-37512	<u>WAVER ROLLER SHAFT</u> - 375, 9800 (PIN NEEDS TO BE REPLACED WITH P-436 TAPER PIN IF CUST. HAS ORIGINAL SHAFT.)
15	P-910	<u>SCREW</u>
16	P-350830	<u>ROLLER &amp; SHAFT ASSEMBLY</u> - (OUR STYLE) 350 COMPLETE WITH GEARS, INCLUDES ITEM #9, THIS PAGE.
	P-360830	<u>ROLLER &amp; SHAFT ASSEMBLY</u> - (OUR STYLE) 360 COMPLETE WITH GEARS, INCLUDES ITEM #9, THIS PAGE.
	P-370830	<u>ROLLER &amp; SHAFT ASSEMBLY</u> - (OUR STYLE) 375 & 9800 COMPLETE WITH GEARS, INCLUDES ITEM #9, THIS PAGE.
17	P-36526	<u>END CAP</u> - 360 NYLON ONLY. 350 OLD STYLE NEEDS NO HUB. SEE ITEM #10A, THIS PAGE.
18	P-35528	<u>ROLLER SHELL</u> - 350 (NYLON) USE WITH ITEM #10A GEAR, #10C GEAR & #19 END CAP.
	P-350831	<u>ROLLER SHELL</u> - 350 (HARD RUBBER OUR STYLE ONLY) USE WITH ITEMS #37 END CAP, #38 END CAP & #40 GEAR.
	P-360831	<u>ROLLER SHELL</u> - 360 (HARD RUBBER OUR STYLE ONLY) USE WITH ITEMS #37 END CAP, #38 END CAP & #40 GEAR.
	P-370831	<u>ROLLER SHELL</u> - 375 & 9800 HARD RUBBER OUR STYLE ONLY) USE WITH ITEMS #37 END CAP, #38 END CAP & #40 GEAR.
	P-36529	<u>ROLLER SHELL</u> - 360 (NYLON) USE WITH ITEMS #10 GEAR, #10B GEAR & #17 & #19A END CAPS.
18A	P-36530	<u>ROLLER SHELL</u> - 360 (NYLON) - INCLUDES ITEMS #17 & #19A. SEE NOTE 2.
	P-37530	<u>ROLLER SHELL</u> - 375 & 9800 (NYLON) SEE NOTE 2.
19	P-35534	<u>END CAP</u> - 350, 360, 375 & 9800 OLD STYLE. USE WITH P-35514 ITEM #10A OR P-36516 ITEM #10C OLD STYLE GEARS.
19A	P-36532	<u>END CAP</u> - 350, 360 - (NYLON ROLLER) NEW STYLE. SEE NOTE 2.
20	P-635	<u>LOCK WASHER</u>
21	P-35444	<u>OSCILLATING ROLLER SCREW</u> - 350 ONLY - 11-1/2" LONG.
22	P-1141	<u>RETAINING RING</u>
23	P-1382	<u>WASHER</u>
24	P-36504	<u>WAVER &amp; CAM GEAR ASSEMBLY</u> - OPERATES WITH CAM #30 PAGE 26 & GEAR #13 PAGE 28.
25	P-1220	<u>BUSHING</u> - (CONTAINS 2).
26	P-36506	<u>STUD - C-RING RETAINER</u>
27	P-507	<u>NUT</u>
28	P-509	<u>NUT</u>
29	P-36536	<u>STUD</u> - IDLER GEAR STUD.
	P-8046	<u>STUD</u> - 9805 TO 9850 ONLY.
30	P-36446	<u>IDLER GEAR ASSEMBLY</u> - (BRASS) OPERATES BETWEEN GEARS #10, #10A, #10B, #10C THIS PAGE & ROLLER #1 PAGE28.
	P-36457	<u>IDLER GEAR ASSEMBLY</u> - (STEEL) OPERATES BETWEEN GEARS #10, #10A, #10B, #10C THIS PAGE & ROLLER #1 PAGE28.
	P-36455	<u>IDLER GEAR ASSEMBLY</u> - (NYLON) OPERATES BETWEEN GEARS #10, #10A, #10B, #10C THIS PAGE & ROLLER #1 PAGE28. THE ABOVE IDLER GEAR ASSEMBLY IS USED TWICE. SEE ITEM #40 PAGE 22.
31	P-1223	<u>BUSHING</u>
32	P-613	<u>WASHER</u>
33	P-705	<u>RETAINING RING</u>
34	P-436	<u>TAPER PIN</u> - PART OF ITEM #9 SHAFT ASSEMBLY.
34A	P-435	<u>TAPER PIN</u> - PART OF ITEM #9 SHAFT ASSEMBLY.
35	P-1592	<u>DRILL BIT</u>
36	P-36433	<u>SCREW</u>
37	P-36528	<u>END CAP</u> - 2 HOLES.
38	P-36527	<u>END CAP</u> - 4 HOLES * THREADED.
39	P-55	<u>SCREW</u>
40	P-36848	<u>GEAR</u> - (360 & 369 NEW DESIGN WITH 2 SCREWS) OPERATES WITH GEAR ITEM #47 PAGE 23 & #30 THIS PAGE. SEE NOTE #1.
41	P-1546	<u>HAND REAMER TOOL</u>
42	P-1590	<u>TAPERED REAMER</u>
43	P-36773	<u>INK WASH-UP ATTACHMENT</u> - (350 & 360) ATTACHES ONTO ITEM #5, PAGE45.
	P-37773	<u>INK WASH-UP ATTACHMENT</u> - (375 ONLY) ATTACHES TO ITEM #5 PAGE 45.
44	P-5365	<u>SCREW</u>
45	P-36775	<u>BLADE SUPPORT</u> - 350 & 360.
	P-37775	<u>BLADE SUPPORT</u> - 375 & 9800
46	P-5028	<u>BLADE</u> - 350 & 360.
	P-36767	<u>BLADE</u> - THIS STYLE FITS ORIGINAL A.B. DICK 350 & 360 WASH UP ATTACHMENT ONLY.
	P-5029	<u>BLADE</u> - 375 ONLY.
47	P-36776	<u>NUT PLATE</u> - 350, 360 375 & 9800.
48	P-36774	<u>INK WASH-UP TRAY ONLY</u> - 350, 360.
	P-37774	<u>INK WASH-UP TRAY ONLY</u> - 375.
49	P-5368	<u>ADJUSTING SCREW</u>
50	P-30200	<u>WASH UP BLADE</u> - METAL BLADE WITH RUBBER EDGE - 6 HOLES. FOR ORIGINAL A.B. DICK 9800 STYLE WASH UP ATTACHMENT.

**NOTE 1:** PILOT HOLE ONLY. MUST HAVE PROPER TOOLS (USE DRILL BIT P-1592)

**NOTE 2:** - ITEMS #17 & #19A END CAPS MUST BE PRESSED INTO ROLLER SHELL ITEM #18A. THESE CANNOT BE USED WITH ITEM #18 AT TOP OF DRAWING 25.

**DRAWING #26**  
**INK OSCILLATING ROLLER (TOP) & DISTRIBUTOR ROLLERS**

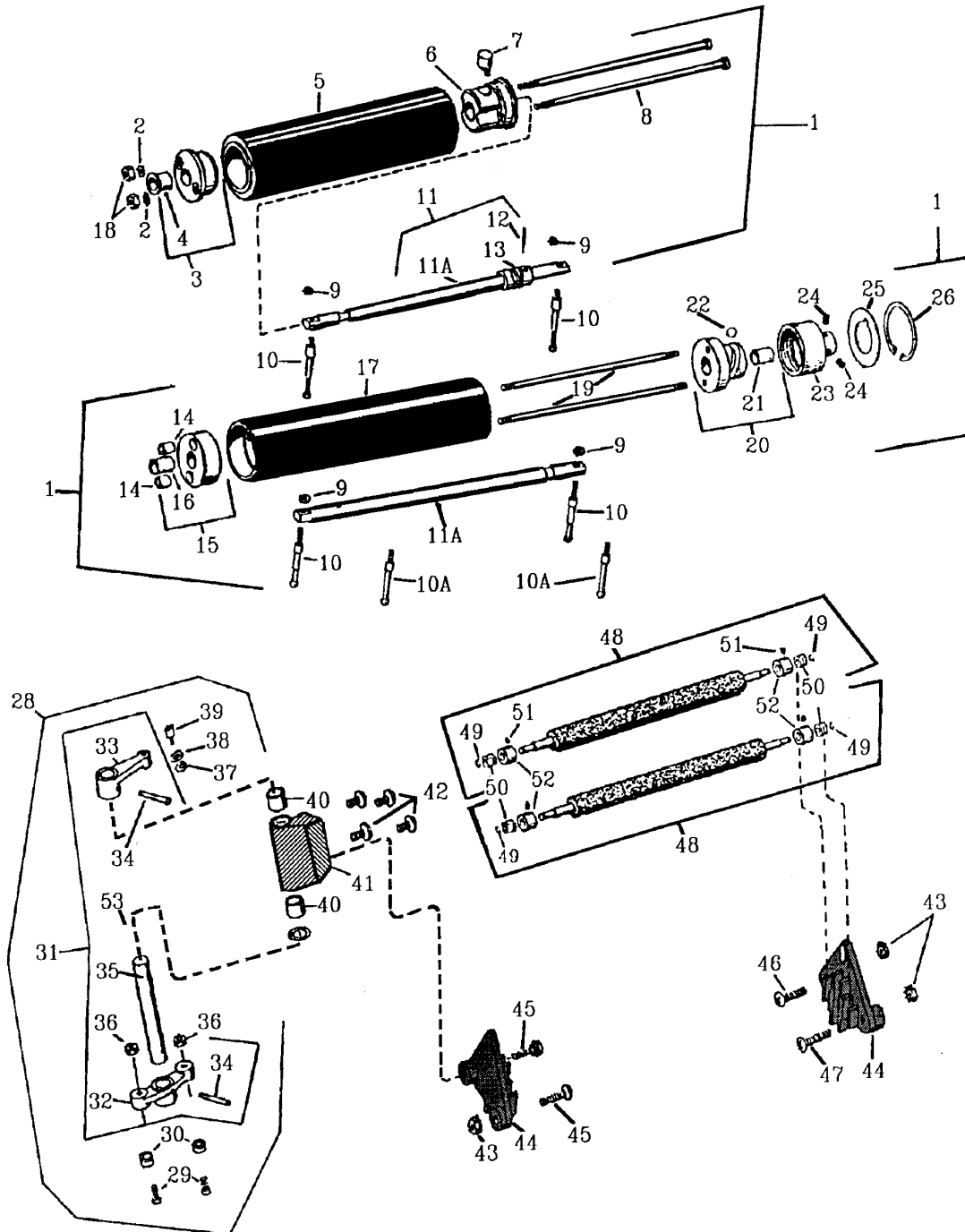

FOR LOCATION OF ROLLER SEE PAGE 27

**PAGE #26**  
**INK OSCILLATING ROLLER (TOP) & DISTRIBUTOR ROLLERS**

KEY #	PART#	DESCRIPTION
1	P-350820	<u>TOP OSCILLATING INK ROLLER</u> - 350 "COMPLETE ROLLER ASSEMBLY" 2-1/2" DIA., 10-1/2" SURFACE LENGTH.
	P-360820	<u>TOP OSCILLATING INK ROLLER</u> - 360 "COMPLETE ROLLER ASSEMBLY" 2-1/2" DIA., 11-1/4" SURFACE LENGTH.
	P-370820	<u>TOP OSCILLATING INK ROLLER</u> - 375 & 9800 "COMPLETE ROLLER ASSEMBLY" 2-1/2" DIA., 13-1/4" SURFACE LENGTH.
	P-350840	<u>TOP OSCILLATING INK ROLLER</u> - 350 "JUMBO" 4" DIA., 10-1/2" SURFACE LENGTH. USE WITH KIT P-35080 DWG. 27.
	P-360840	<u>TOP OSCILLATING INK ROLLER</u> - 360 "JUMBO" 4" DIA., 11-1/4" SURFACE LENGTH. USE WITH KIT P-36080 DWG. 27.
	P-370840	<u>TOP OSCILLATING INK ROLLER</u> - 375 & 9800 "JUMBO" 4" DIA. 13-1/4" SURFACE LENGTH. USE WITH KIT P-37080 DWG. 27.
2	P-635	<u>LOCKWASHER</u>
3	OBSOLETE	<u>CAP &amp; BUSHING ASSEMBLY</u> - SEE NOTE.
4	P-1315	<u>BUSHING</u>
5	OBSOLETE	TOP INK OSCILLATING ROLLER SHELL - USE P-350820 FOR 350. SEE NOTE.
6	OBSOLETE	<u>ROLLER CAP</u> - USE P-350820 FOR 350. OR P-360820 FOR 360. SEE NOTE.
7	P-36463	<u>DOG</u> - WORKS WITH WORM ITEM #13, THIS PAGE.
	P-120846	<u>DOG</u> - FOR P-370845 SHAFT.
8	P-35444	<u>OSCILLATING ROLLER SCREW</u> - 350 11-1/2" LONG.
	P-36444	<u>OSCILLATING ROLLER SCREW</u> - 360 10-1/2" LONG.
9	P-469	<u>NUT</u>
10	P-36460	<u>MOUNTING SCREW</u> - STD. 350, 360, 369, 375, 385. FITS INTO ITEM #44 THIS PAGE.
10A	P-6046	<u>PIN</u> - SPECIAL FOR 360 PRO & 9800 PRO.
11	P-36462	<u>SHAFT ASSEMBLY</u>
11A	P-36472	<u>SHAFT ONLY</u> - 350 & 360 (NO GROOVES).
	P-37472	<u>SHAFT ONLY</u> - 375 & 9800 (NO GROOVES).
	P-370845	<u>SHAFT ONLY</u> - 375 & 9800 (WITH GROOVES).
12	P-380	<u>ROLL PIN</u>
13	P-36464	<u>WORM</u>
14	P-36448	<u>SPECIAL NUT</u>
15	P-36466	<u>OSCILLATING ROLLER END CAP</u>
16	P-1221	<u>BUSHING</u>
17	P-36456	<u>TOP OSCILLATING INK ROLLER</u>
	P-37456	<u>TOP OSCILLATING INK ROLLER</u>
18	P-478	<u>NUT</u>
19	P-36470	<u>TIE ROD</u>
	P-37470	<u>TIE ROD</u>
20	P-36468	<u>END CAP &amp; CAM ASSEMBLY</u>
21	P-1223	<u>BUSHING</u>
22	P-756	<u>STEEL BALL</u>
23	P-36474	<u>OSCILLATING ROLLER CAP</u>
24	P-25	<u>SET SCREW</u>
25	P-36476	<u>SPLASH GUARD</u>
26	P-693	<u>RETAINING RING</u>
28	P-36482	<u>WAVER OPERATING ASSEMBLY</u> - N.O.S. - 350, 360, 375, 9800 STANDARD DAMPENER. OPERATES WITH ITEM #2, PAGE 21 & ITEMS #3 & #24, PAGE 25.
	P-98482	<u>WAVER OPERATING ASSEMBLY</u> - N.O.S. - 9800 MOTORIZED DAMPENER. OPERATES WITH #2 PAGE 21 & 3 & #24 PAGE 25.
29	P-8005	<u>SHOULDER SCREW</u>
30	P-1409	<u>CAM</u> - OPERATES ITEM #3 & #24 PAGE 25.
31	P-36484	<u>LEVER ASSEMBLY</u> - 350, 360, 375, 9800 STANDARD DAMPENER.
	P-98484	<u>LEVER ASSEMBLY</u> - 9800 MOTORIZED DAMPENER.
32	P-36486	<u>LEVER</u> - OPERATES CAM & GEAR ASSEMBLY #24 & COUPLING #3 PAGE 25. SOLD SEPARATELY FOR FIELD REPLACEMENT TBUT IT IS RECOMENDED THAT YOU BUY THE COMPLETE ASSEMBLY P-36484 TO INSURE PROPER TIMING AND ALIGNMENT.
33	P-36480	<u>WAVER OPERATING LEVER</u> - NEW STYLE OPERATES COUPLE ROLLER #2 PAGE 21. SOLD SEPARATELY FOR FIELD REPLACEMENT TBUT IT IS RECOMENDED THAT YOU BUY THE COMPLETE ASSEMBLY P-36484 TO INSURE PROPER TIMING AND ALIGNMENT.
34	P-431	<u>TAPER PIN</u>
35	P-36486	<u>WAVER OPERATING SHAFT</u> - (NOT SOLD SEPARATELY, SEE P-36484 or P-98484 ITEM #31 THIS PAGE)
36	P-521	<u>NUT</u>
37	P-469	<u>NUT</u>
38	P-569	<u>WASHER</u>
39	P-7001	<u>ECCENTRIC SCREW</u> - OPERATES ITEM #2, PAGE 21
	P-7014	<u>ECCENTRIC SCREW</u> - (9800 DAMPENER)
40	P-822	<u>BUSHING</u> - USE WITH OLD STYLE BRACKET
41	P-36492	<u>BRACKET ASSEMBLY</u> - NEW STYLE, NEEDS NO BUSHING
42	P-943	<u>HEX HEAD SCREW</u>
43	P-487	<u>NUT</u>
44	P-36494	<u>MOUNTING BRACKET</u>
45	P-946	<u>HEX HEAD SCREW</u>
46	P-948	<u>SCREW</u>
47	P-949	<u>SCREW</u>
48	P-35020	<u>INK DISTRIBUTOR ROLLER</u> - (350) 1" DIAMETER WITH OILITE BUSHINGS & SPACER COLLARS, LOCATED UNDERNEATH TOP OSCILLATING INK ROLLER
	P-35021	<u>INK DISTRIBUTOR ROLLER</u> - (350) 1 1/8" DIAMETER WITH OILITE BUSHINGS & SPACER COLLARS
	P-35022	<u>INK DISTRIBUTOR ROLLER</u> - (350) 1 1/4" DIAMETER WITH OILITE BUSHINGS & SPACER COLLARS
	P-36020	<u>INK DISTRIBUTOR ROLLER</u> - (360) 1" DIAMETER WITH OILITE BUSHINGS & SPACER COLLARS
	P-36021	<u>INK DISTRIBUTOR ROLLER</u> - (360) 1 1/8" DIAMETER WITH OILITE BUSHINGS & SPACER COLLARS
	P-36022	<u>INK DISTRIBUTOR ROLLER</u> - (360) 1 1/4" DIAMETER WITH OILITE BUSHINGS & SPACER COLLARS
	P-37020	<u>INK DISTRIBUTOR ROLLER</u> - (375 & 9800) 1" DIAMETER WITH OILITE BUSHINGS & SPACER COLLARS
	P-37021	<u>INK DISTRIBUTOR ROLLER</u> - (375 & 9800) 1 1/8" DIAMETER WITH OILITE BUSHINGS & SPACER COLLARS
	P-37022	<u>INK DISTRIBUTOR ROLLER</u> - (375 & 9800) 1 1/4" DIAMETER WITH OILITE BUSHINGS & SPACER COLLARS
49	P-682	<u>SNAP RING</u>
50	P-1340	<u>BUSHING</u>
51	P-4	<u>SCREW</u>
52	P-1446	<u>COLLAR</u>
53	P-1494	<u>WASHER</u> - 9800 ONLY

DRAWING #26A  
INK OSCILLATING ROLLER (LOWER) FOR 360 PRO & 9800 PRO

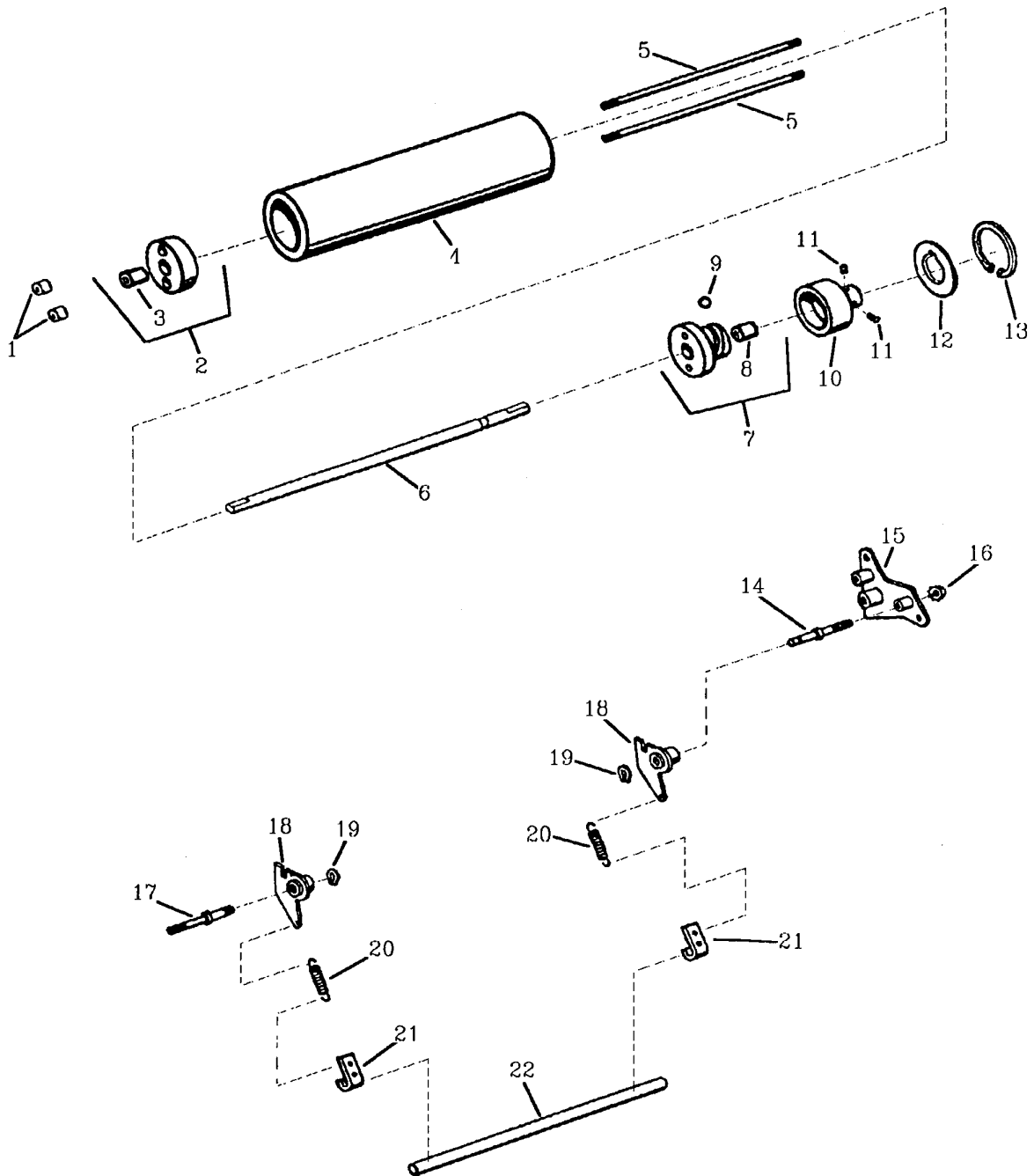

**PAGE #26A**  
**INK OSCILLATING ROLLER (LOWER) FOR 360 PRO & 9800 PRO**

KEY #	PART#	DESCRIPTION
1	P-36448	<u>SPECIAL NUT</u>
2	P-36466	<u>OSCILLATING ROLLER END CAP</u>
3	P-1221	<u>BUSHING</u>
4	P-360870	<u>ROLLER ASSEMBLY COMPLETE</u> - 360 PRO. (HARD RUBBER) OUR STYLE. NOT SHOWN.
	P-370870	<u>ROLLER ASSEMBLY COMPLETE</u> - 9800 PRO. (HARD RUBBER) OUR STYLE. NOT SHOWN.
4A	P-360821	<u>ROLLER SHELL ONLY</u> - 360 PRO. (HARD RUBBER) OUR STLYE.
	P-370821	<u>ROLLER SHELL ONLY</u> - 9800 QP, QPC, PRO. (HARD RUBBER) OUR STLYE.
	P-36456	<u>ROLLER SHELL</u> - 360 PRO. (NYLON) IS NOT PART OF ASSEMBLY ITEM #4.
	P-37456	<u>ROLLER SHELL</u> - 9800 QP, QPC & PRO. (NYLON) IS NOT PART OF ASSEMBLY ITEM #4.
5	P-36470	<u>TIE ROD</u> - 360 PRO.
	P-37470	<u>TIE ROD</u> - 9800 PRO.
6	P-36478	<u>ROLLER SHAFT</u> - 360 PRO.
	P-98472	<u>ROLLER SHAFT</u> - 9800 PRO.
	P-36468	<u>END CAP &amp; CAM ASSEMBLY</u>
8	P-1221	<u>BUSHING</u>
9	P-756	<u>BALL</u>
10	P-36474	<u>END CAP</u>
11	P-25	<u>SET SCREW</u>
12	P-36476	<u>GUARD</u>
13	P-693	<u>RETAINING RING</u> - INTERNAL.
14	P-9056	<u>STUD</u>
15	P-98552	<u>BRACKET</u>
16	P-487	<u>HEX NUT</u>
17	P-9057	<u>STUD</u>
18	P-36458	<u>ARM ASSEMBLY</u>
19	P-669	<u>C-RING</u>
20	P-36459	<u>SPRING</u>
21	P-98560	<u>SPRING ANCHOR CLIP</u>
22	P-37635	<u>TIE BAR</u> - FOR LOCATION SEE ITEM #8, PAGE 46.

**DRAWING #27**  
**SUPER INKER UNIT & ROLLER SCHEME**

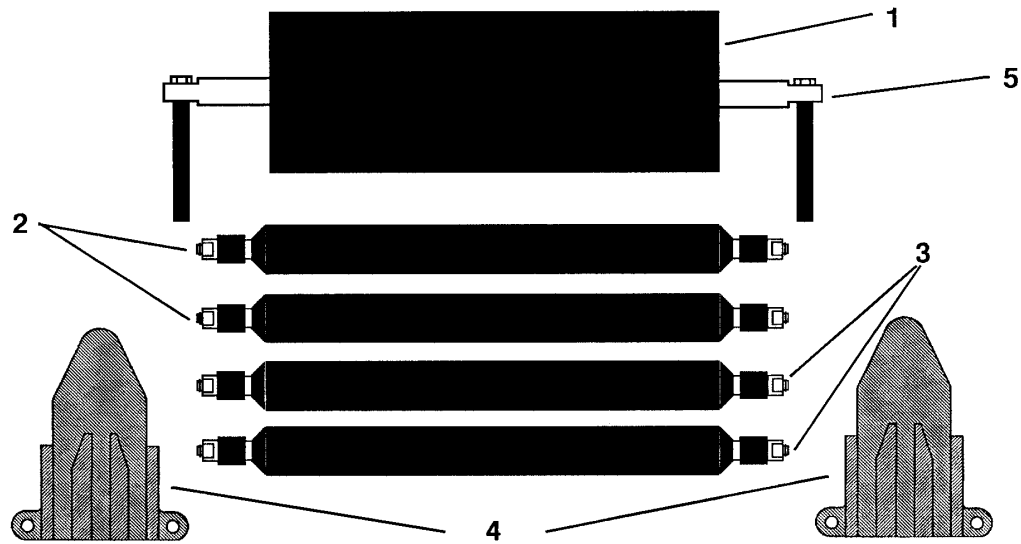

**JUMBO ROLL CANNOT BE USED WITHOUT BRACKETS & FOUR DISTRIBUTOR ROLLERS.**

**SUPER INKER REPLACES TOP INK OSCILLATOR "E" WITH A JUMBO ROLLER, AND REPLACES THE TWO DISTRIBUTOR ROLLERS "D & F" WITH FOUR LARGER ROLLERS.**

**STANDARD ROLLER SYSTEM**

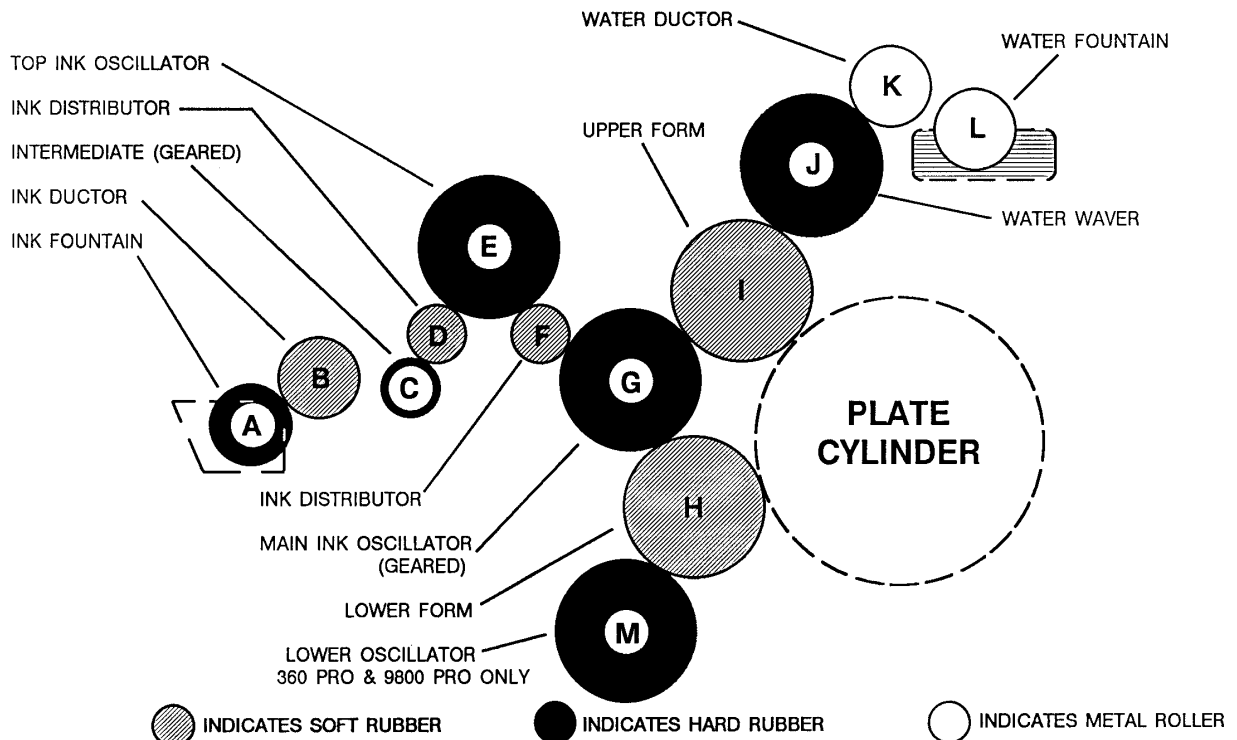

**PAGE #27**  
**SUPER INKER UNIT & ROLLER SCHEME**

KEY #	PART#	DESCRIPTION
<b>MODEL 350</b>		
1	P-35080	<u>350 SUPER INKER KIT - "COMPLETE"</u>
2	P-350840	<u>JUMBO OSCILLATING INK ROLL - (4" DIAMETER)</u>
3	P-35021	<u>INK DISTRIBUTOR ROLL - (1-1/8" DIAMETER) 2 PER KIT</u>
4	P-35022	<u>INK DISTRIBUTOR ROLL - (1-1/4" DIAMETER) 2 PER KIT</u>
5	P-35000	<u>DISTRIBUTOR ROLL BRACKETS - "PAIR" - (SEE NOTE BELOW)</u>
	P-360845	<u>JUMBO OSCILLATING ROLLER SHAFT</u>
<b>MODEL 360</b>		
1	P-36080	<u>360 SUPER INKER KIT - "COMPLETE"</u>
2	P-360840	<u>JUMBO OSCILLATING INK ROLL - (4" DIAMETER)</u>
3	P-36021	<u>INK DISTRIBUTOR ROLL - (1 1/8") 2 PER KIT</u>
4	P-36022	<u>INK DISTRIBUTOR ROLL - (1-1/4" DIAMETER) 2 PER KIT</u>
5	P-35000	<u>DISTRIBUTOR ROLL BRACKETS - "PAIR" - (SEE NOTE BELOW)</u>
	P-360845	<u>JUMBO OSCILLATING ROLLER SHAFT</u>
<b>MODEL 375/9800</b>		
1	P-37080	<u>375/9800 SUPER INKER KIT - "COMPLETE"</u>
2	P-370840	<u>JUMBO OSCILLATING INK ROLL - (4" DIAMETER)</u>
3	P-37021	<u>INK DISTRIBUTOR ROLL - (1 1/8" DIAMETER)</u>
4	P-37022	<u>INK DISTRIBUTOR ROLL - (1 1/4" DIAMETER) 2 PER KIT</u>
5	P-35000	<u>DISTRIBUTOR ROLL BRACKETS - "PAIR" - (SEE NOTE BELOW)</u>
	P-370845	<u>JUMBO OSCILLATING ROLLER SHAFT</u>
<p><b>NOTE:</b> ITEM #4, P-35000 BRACKETS ARE SOLD AS A "PAIR" <u>ONLY</u> IF BOUGHT WITH COMPLETE SUPER INKER KIT. P-35000 BRACKETS ARE AVAILABLE AS INDIVIDUAL PIECES..</p>		

**DRAWING #28**  
**INK DUCTOR UNIT & GEARED INTERMEDIATE ROLLER**

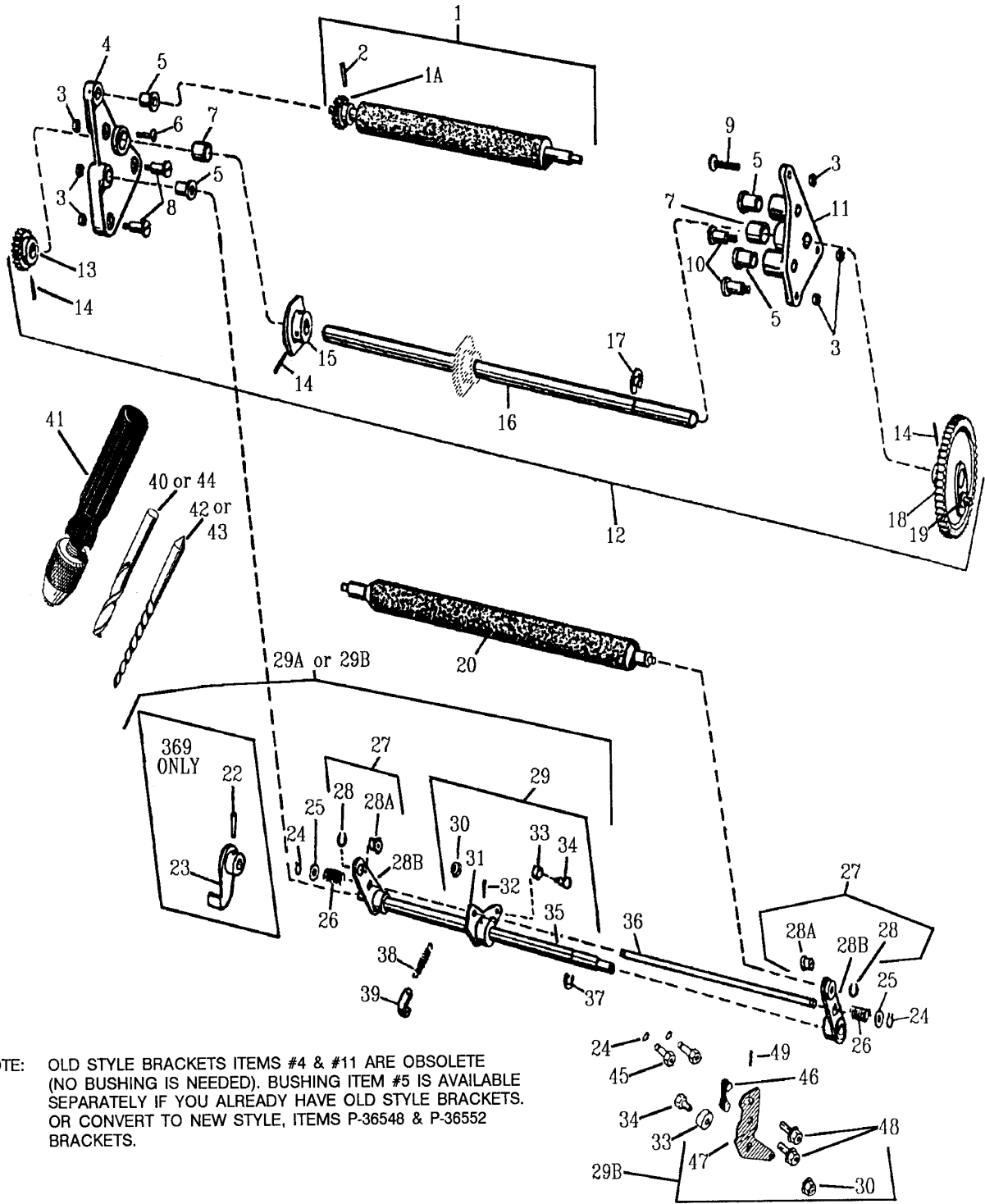



**PAGE #28**  
**INK DUCTOR UNIT & GEARED INTERMEDIATE ROLLER**

KEY #	PART#	DESCRIPTION
1	P-36029	<u>INTERMEDIATE OR DISTRIBUTOR 360 INK ROLLER &amp; GEAR</u> - OPERATES WITH GEAR ITEM #30, page 25.
1A	P-36534	<u>INTERMEDIATE GEAR - PILOT HOLE ONLY. MUST HAVE DRILL BIT P-1381 TO INSTALL.</u>
	P-37029	<u>INTERMEDIATE OR DISTRIBUTOR 375/9800 INK ROLLER &amp; GEAR</u> - OPERATES WITH GEAR ITEM #30, PAGE 25.
2	P-346	<u>SPIRAL PIN</u>
3	P-487	<u>NUT</u>
4	P-36548	<u>BEARING BRACKET ASSEMBLY</u> - MOUNTS TO UPPER SIDE FRAME, NON OPERATOR SIDE
5	P-1250	<u>BUSHING</u> - THIS BUSHING IS NOT NEEDED ON NEW STYLE BRACKET. USE ONLY FOR OLD STYLE.
6	P-1556	<u>SCREW - PHILLIPS</u>
	P-946	<u>SCREW - HEX HEAD</u>
7	P-1222	<u>BUSHING</u>
8	P-8008	<u>SHOULDER SCREW</u>
9	P-949	<u>SCREW</u>
10	P-8009	<u>SHOULDER SCREW</u>
11	P-36552	<u>BEARING BRACKET ASSEMBLY</u> - MOUNTS TO OUTSIDE UPPER SIDE FRAME, OPERATOR SIDE
	P-98552	<u>BEARING BRACKET ASSEMBLY</u> - MOUNTS TO OUTSIDE UPPER SIDE FRAME, OPERATOR SIDE, 9800 ONLY
12	P-36696	<u>CAM &amp; GEAR SHAFT ASSEMBLY</u> - 350, 360, 369.
	P-36442	<u>CAM &amp; GEAR SHAFT ASSEMBLY</u> - 360 PRO.
	P-37442	<u>CAM &amp; GEAR SHAFT ASSEMBLY</u> - 375
	P-98442	<u>CAM &amp; GEAR SHAFT ASSEMBLY</u> - 9800
13	P-36538	<u>GEAR</u> - OPERATES WITH GEAR #24, PAGE 25. MUST HAVE DRILL BIT P-1589 & HAND REAMER P-1546 & REAMER BIT P-1590.
14	P-436	<u>TAPER PIN</u> - CONTAINS 2
15	P-36542	<u>CAM</u> - SEE CAM ROLLER ITEM #33. MUST HAVE HAND REAMER P-1546 & REAMER BIT P-1590
	P-98542	<u>CAM</u> - 9800
16	P-36544	<u>SHAFT</u> - MUST HAVE DRILL BIT P-1589, HAND REAMER P-1546 & REAMER BIT P-1590.
	P-37544	<u>SHAFT</u> - MUST HAVE DRILL BIT P-1589, HAND REAMER P-1546 & REAMER BIT P-1590.
17	P-672	<u>C-RING</u>
18	P-36554	<u>GEAR</u> - 360 PRO, 9810. OPERATES W/GEAR #13, PAGE 25. NEED DRILL BIT P-1589, TOOL P-1546 & REAMER BIT P-1590.
	P-36684	<u>GEAR</u> - 350, 360, 369 & 375. OPERATES W/GEAR #11 PAGE 29A. NEED DRILL BIT P-1589, TOOL P-1546 & REAMER BIT P-1590.
19	P-36556	<u>PIN</u> - LINKS TO ITEM #11 PAGE 29A OR ITEM #15 PAGE 29B.
20	P-35030	<u>INK DUCTOR ROLLER</u> - 350.
	P-36030	<u>INK DUCTOR ROLLER</u> - 360.
	P-37030	<u>INK DUCTOR ROLLER</u> - 375 & 9800.
22	P-427	<u>TAPER PIN</u> - 369 ONLY.
23	P-36580	<u>LEVER</u> - 369 ONLY.
24	P-698	<u>RETAINING RING</u>
25	P-586	<u>WASHER</u>
26	P-35289	<u>COMPRESSION SPRING</u>
27	P-36572	<u>LEVER ASSEMBLY</u>
28	P-703	<u>C-RING</u> - USE 2, 1 PER LEVER.
28A	P-1569	<u>BUSHING</u> - 350, 360, 375 & 9800. USE 2, 1 PER LEVER.
	P-1568	<u>BUSHING</u> - 380, 382, 385. 1 PER LEVER.
28B	P-36569	<u>LEVER ONLY</u>
29	P-36570	<u>SHAFT &amp; LEVER ASSEMBLY</u> - LOCATED UNDERNEATH INK DUCTOR ROLLER.
	P-37570	<u>SHAFT &amp; LEVER ASSEMBLY</u> - LOCATED UNDERNEATH INK DUCTOR ROLLER.
29A	P-36576	<u>SHAFT &amp; LEVER ASSEMBLY</u> - 369 ONLY. ITEM #22, #23 & #29.
29B	P-98570	<u>SHAFT &amp; LEVER ASSEMBLY</u> - 9800 ONLY. INCLUDES ITEM #47, #34, #33 & #30.
30	P-472	<u>NUT</u>
	P-473	<u>LOCK NUT</u> - FOR USE WITH OUR CAM KIT P-36500. <i>SEE NOTE.</i>
31	P-36564	<u>LEVER ASSEMBLY</u> - 350, 360 & 369. MUST HAVE PROPER TOOLS. HAND REAMER P-1546 & REAMER BIT P-1547.
	P-37564	<u>LEVER ASSEMBLY</u> 375 & 9800. MUST HAVE PROPER TOOLS. HAND REAMER P-1546 & REAMER BIT P-1547.
32	P-425	<u>TAPER PIN</u>
32A	P-36500	<u>CAM KIT</u> - <i>SEE NOTE.</i>
32B	P-36501	<u>CAM KIT</u> - <i>SEE NOTE.</i>
33	P-1418	<u>CAM ROLLER</u> - ROLLS ON CAM #15, THIS PAGE.
	P-767	<u>SEALED BEARING</u> - FOR USE WITH OUR CAM KIT P-36500. <i>SEE NOTE.</i>
34	P-8010	<u>ECCENTRIC SHOULDER SCREW</u>
	P-1527	<u>CAP SCREW</u> - FOR USE WITH OUR CAM KIT P-36500. <i>SEE NOTE.</i>
35	P-36568	<u>SHAFT</u> - PILOT HOLE ONLY. MUST HAVE HAND REAMER P-1546 & REAMER BIT P-1547.
	P-36578	<u>SHAFT</u> - 369 ONLY. PILOT HOLE ONLY. MUST HAVE HAND REAMER P-1546 & REAMER BIT P-1547.
	P-37568	<u>SHAFT</u> - PILOT HOLE ONLY. MUST HAVE HAND REAMER P-1546 & REAMER BIT P-1547.
36	P-36550	<u>INK DUCTOR BAR</u> - LOCATED UNDERNEATH INK FOUNTAIN ROLLER.
	P-37550	<u>INK DUCTOR BAR</u> - LOCATED UNDERNEATH INK FOUNTAIN ROLLER.
	P-98550	<u>INK DUCTOR BAR</u> - LOCATED UNDERNEATH INK FOUNTAIN ROLLER.
37	P-670	<u>SNAP RING</u>
38	P-36549	<u>SPRING</u>
39	P-36560	<u>SPRING ANCHOR CLIP</u> - CONNECTS TO TIE BAR ITEM #5 PAGE 45.
40	P-1589	<u>DRILL BIT</u> - FOR ITEMS #12, #16 & #18 THIS PAGE.
41	P-1546	<u>HAND REAMER</u>
42	P-1590	<u>REAMER BIT</u> - FOR ITEM #18 THIS PAGE.
43	P-1547	<u>REAMER BIT</u> - FOR ITEM #1A THIS PAGE.
44	P-1381	<u>DRILL BIT</u> - FOR ITEM #1A THIS PAGE.
45	P-98555	<u>STAND OFF STUD</u>
46	P-98289	<u>SPRING</u>
47	NO NO.#	<u>LEVER</u> - NOT SOLD SEPARATELY. USE ITEM #29B P-98570.
48	P-81	<u>SCREW</u>
49	P-428	<u>TAPER PIN</u>
		<u>NOTE:</u> PROLONG THE LIFE OF YOUR CAMS #15 & #33 BY USING OUR NEW STYLE CAM KIT #P-36500. WE USE A SEALED BEARING IN PLACE OF THE STANDARD CAM, REDUCING FRICTION AND ALLOWING SMOOTHER OPERATION FOR THE INK DUCTOR, #29, THIS PAGE.
		<b>IMPROVED CAM KIT</b> P-36500 CONSISTS OF:
		1) P-1527 SCREW
		1) P-767 BEARING
		1) P-626 LOCKWASHER
		2) P-586 WASHERS
		1) P-473 NUT
		<b>STANDARD CAM KIT</b> P-36501 CONSISTS OF:
		1) P-8010 SCREW
		1) P-1418 CAM
		1) P-472 NUT

**DRAWING #29A**  
**INK FOUNTAIN UNIT & FOUNTAIN ROLLER - 350, 360, 375, 9800 O.S.**

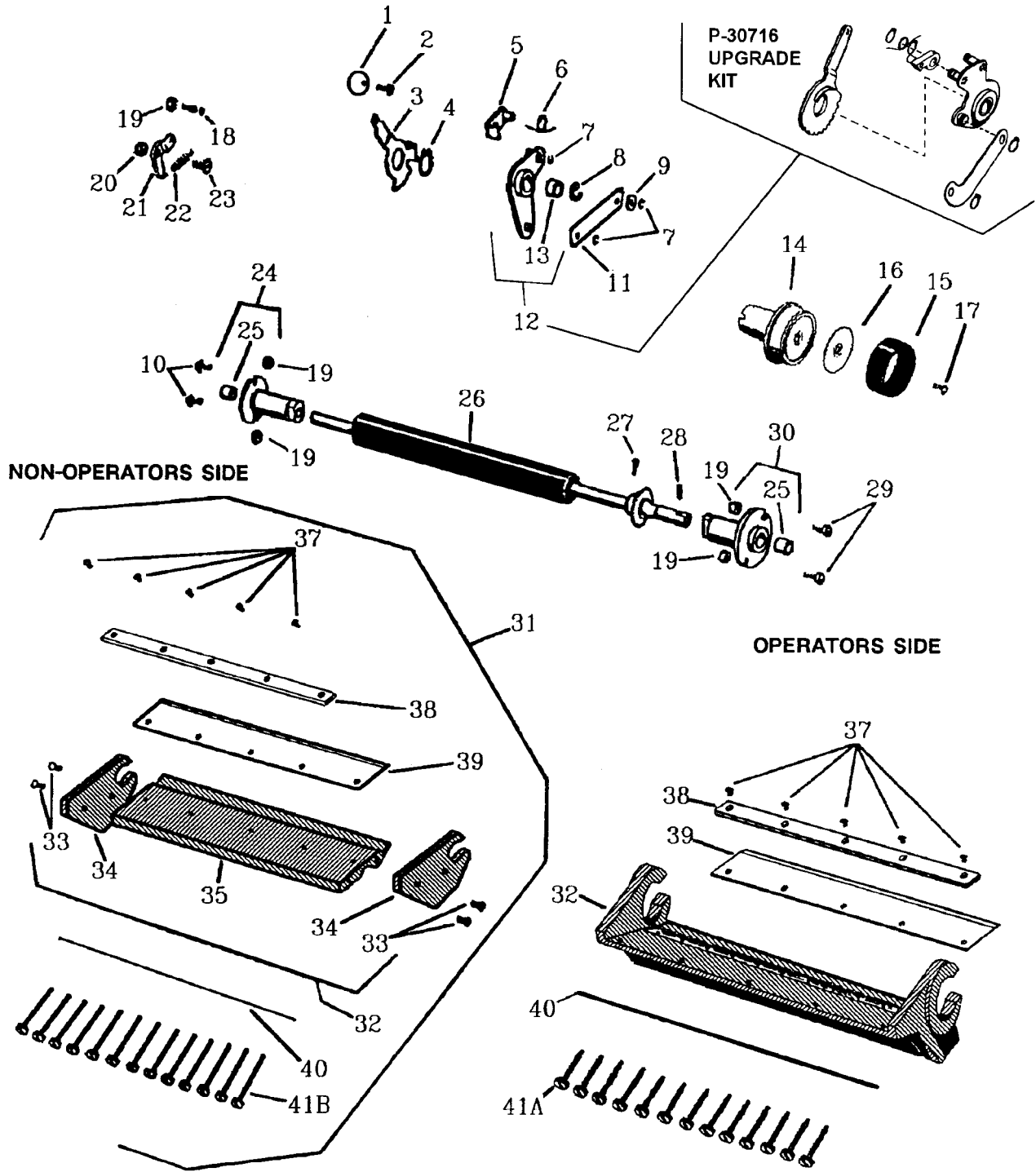

## INK FOUNTAIN UNIT &amp; FOUNTAIN ROLLER - 350, 360, 369, 375, 9800 O.S.

KEY #	PART#	DESCRIPTION
1	P-36270	<u>KNOB</u>
2	P-993	<u>SCREW</u>
3	P-36269	<u>RATCHET LEVER</u> - (4 POSITION) SEE ITEM #53, PAGE 47.
4	P-711	<u>RETAINING RING</u>
5	P-36268	<u>PAWL</u>
6	P-36267	<u>LOOP SPRING</u>
7	P-700	<u>RETAINING RING</u>
8	P-672	<u>C-RING</u>
9	P-596	<u>WASHER</u>
10	P-263	<u>SCREW</u>
11	P-36265	<u>OPERATING LINK</u> - FOR 350, 360, 369 & 375 & (360 PRO STANDARD INK UNIT) ATTACHES TO ITEM #19, PAGE 28.
12	OBSOLETE	<u>INK OPERATING LEVER</u> - NO LONGER AVAILABLE. USE UPGRADE KIT P-30716 FOR REPLACEMENT.
13	P-1221	<u>BUSHING</u>
14	P-36242	<u>INK KNOB</u> - SEE ITEM #54, PAGE 47.
15	P-36244	<u>HAND GRIP TIRE</u>
16	P-36361	<u>DISC</u>
17	P-300	<u>SCREW</u>
18	P-6007	<u>SPRING ANCHOR</u>
19	P-471	<u>LOCK NUT</u>
20	P-487	<u>NUT</u>
21	P-36355	<u>RATCHET LOCK</u> - ATTACHES TO UPPER SIDE FRAME
22	P-36264	<u>SPRING</u>
23	P-8011	<u>SHOULDER SCREW</u>
24	P-36317	<u>ROLLER BEARING</u> - NON-OPERATOR SIDE
25	P-1221	<u>BUSHING</u>
26	P-35035	<u>INK FOUNTAIN ROLLER</u> - (FOR 350 SER. NO. 235601 AND LOWER,) 10-33/64" SURFACE
	P-36035	<u>INK FOUNTAIN ROLLER</u> - (FOR 360,360 PRO OLD STYLE,369,AND 350 SER. NO. 235602 AND HIGHER) 11-1/64" SURFACE
	P-37035	<u>INK FOUNTAIN ROLLER</u> - 375/9800
27	P-428	<u>TAPER PIN</u>
28	P-350	<u>ROLL PIN</u>
29	P-172	<u>SCREW</u>
	P-263	<u>SCREW</u> - 369
30	P-36319	<u>ROLLER BEARING</u> - OPERATOR SIDE
31	P-35071	<u>INK FOUNTAIN ASSEMBLY</u> - FOR 350 (OLD STYLE FOUNTAIN) SEE NOTE AT BOTTOM OF PAGE.
	P-36778	<u>INK FOUNTAIN ASSEMBLY</u> - FOR 360, 360 PRO OLD STYLE,AND 369. SEE NOTE AT BOTTOM OF PAGE.
	P-37778	<u>INK FOUNTAIN ASSEMBLY</u> - FOR 375 & 9800. SEE NOTE AT BOTTOM OF PAGE.
	P-98071	<u>INK FOUNTAIN ASSEMBLY</u> - 9800 QPC & PRO. SEE NOTE AT OF PAGE
32	P-35072	<u>INK FOUNTAIN</u> - FOR 350.
	P-36789	<u>INK FOUNTAIN</u> - FOR 360, 360 PRO OLD STYLE,AND 369. (NEW STYLE)
	P-37789	<u>INK FOUNTAIN</u> - FOR 375 & 9800. (NEW STYLE)
33	P-262	<u>SCREW</u>
34	P-36792	<u>END CAP</u> - BOTH SIDES. (NEW STYLE).
35	P-35075	<u>INK FOUNTAIN MID - SECTION</u> - FOR 350
	P-36075	<u>INK FOUNTAIN MID - SECTION</u> - FOR 360, 360 PRO OLD STYLE, & 369 tOLD STYLE FOUNTAIN)
	P-37075	<u>INK FOUNTAIN MID - SECTION</u> - 375 & 9800
	P-118	<u>SCREW</u>
38	P-35082	<u>BLADE CLAMP</u> - FOR 350
	P-36082	<u>BLADE CLAMP</u> - FOR 360, 360 PRO OLD STYLE & 369.
	P-37082	<u>BLADE CLAMP</u> - 375 & 9800
	P-98082	<u>INK BLADE CLAMP</u> - 9800 PP & PRO
39	P-35079	<u>INK BLADE</u> - FOR 350, 1-3/4" WIDE. (OLD STYLE FOUNTAIN)
	P-35233	<u>INK BLADE</u> - FOR 350, 2-7/8" WIDE. (NEW STYLE FOUNTAIN)
	P-36079	<u>INK BLADE</u> - FOR 360, 360 PRO OLD STYLE & 369, 1-3/4" WIDE (OLD STYLE FOUNTAIN)
	P-36233	<u>INK BLADE</u> - FOR 360, 360 PRO OLD STYLE & 369 2-7/8" WIDE (NEW STYLE FOUNTAIN)
	P-37079	<u>INK BLADE</u> - 375 8 9800, 1-3/4" WIDE. (OLD STYLE FOUNTAIN)
	P-37233	<u>INK BLADE</u> - 375 & 9800, 2-7/8" WIDE. (NEW STYLE FOUNTAIN)
40	P-35084	<u>WIRE</u> - FOR 350
	P-36084	<u>WIRE</u> - FOR 360, 360 PRO, & 369
	P-37084	<u>WIRE</u> - FOR 375 & 9800
41A	P-1571	<u>INK FOUNTAIN ADJUSTING SCREW</u> - 1-1/4" LONG
41B	P-1570	<u>INK FOUNTAIN ADJUSTING SCREW</u> - 2-1/4" LONG
42	P-36279	<u>INK FOUNTAIN ASSEMBLY &amp; ROLLER KIT</u> - 360 & 369 - NOT ILLUSTRATED, (SEE NOTE).
	P-37279	<u>INK FOUNTAIN ASSEMBLY &amp; ROLLER KIT</u> - 375 & 9800 QP & PRO - NOT ILLUSTRATED. (SEE NOTE).
<p><b>NOTE:</b>When replacing ink fountains keep in mind that a worn ink fountain roller may cause leakage on the sides of the ink fountain. To eliminate this problem we offer you a kit that includes an ink fountain assembly (item #31, this page) and a new fountain roller (item #26, this page). See item #42.</p>		

**DRAWING #29B**  
**INK FOUNTAIN (METERING) UNIT - 360 PRO**

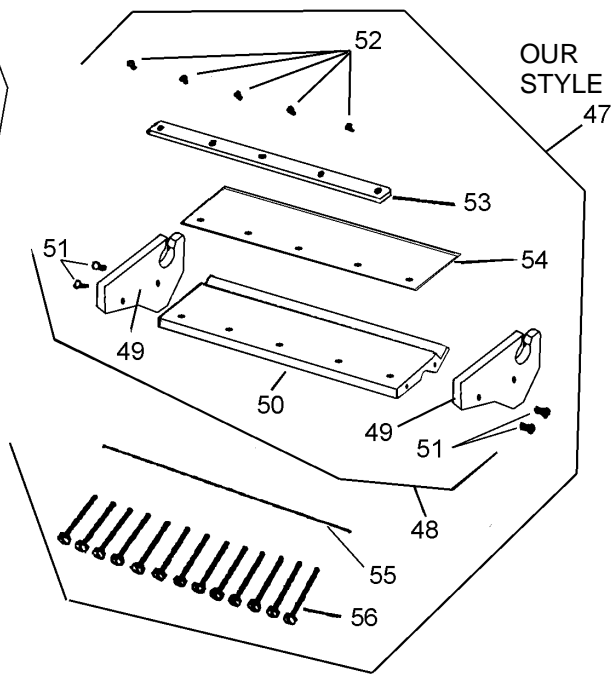
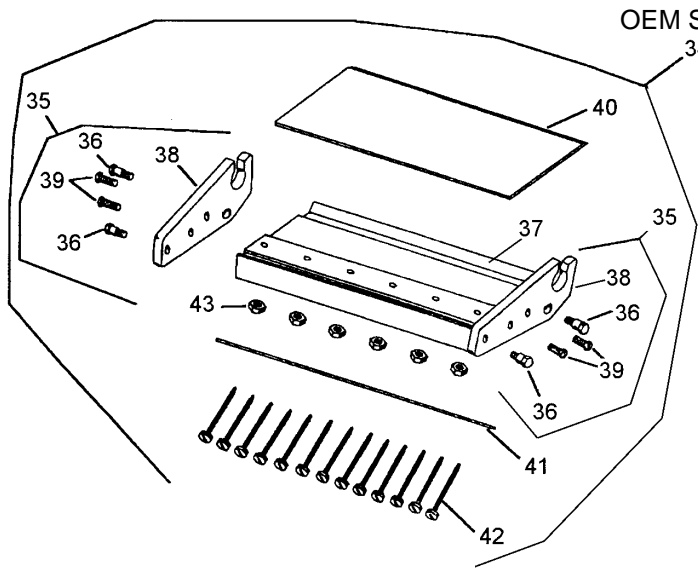
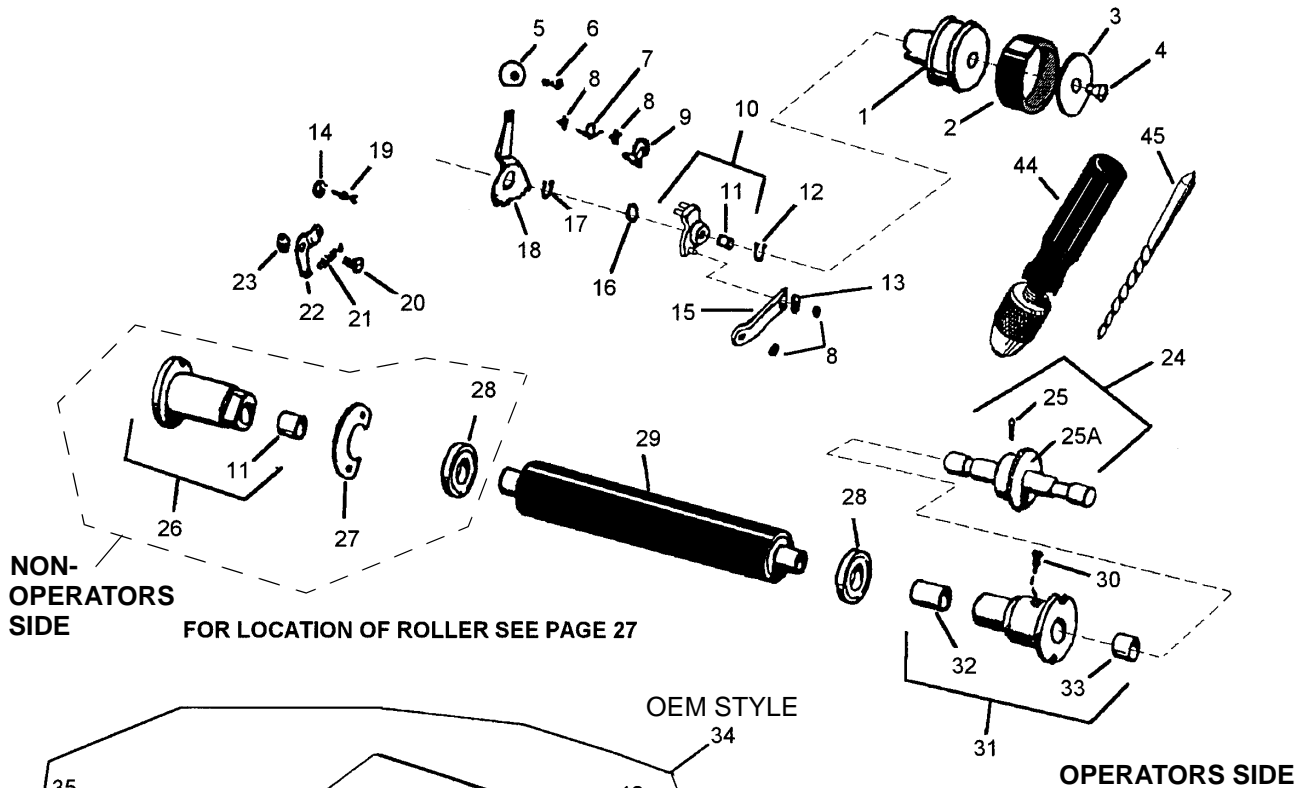

NOTE: Items #35 & #37 are not available separately at this time. Must buy complete assembly item #34 or item #47.

**PAGE #29B**  
**INK FOUNTAIN (METERING) UNIT - 360 PRO**

KEY #	PART#	DESCRIPTION
1	P-36242	<u>INK KNOB</u> - SEE ITEM #54, PAGE 47.
2	P-36244	<u>HAND GRIP TIRE</u>
3	P-36361	<u>DISC</u>
4	P-300	<u>SCREW</u>
5	P-36270	<u>KNOB</u> - SEE ITEM #53, PAGE 47.
6	P-993	<u>SCREW</u>
7	P-36248	<u>LOOP SPRING</u> - CANNOT BE USED ON STANDARD 360. USE ONLY ON 360 PRO.
8	P-700	<u>RETAINING RING</u>
9	P-36251	<u>PAWL</u> - OPERATING LEVER
10	P-36254	<u>INK OPERATING LEVER</u>
11	P-1221	<u>BUSHING</u>
12	P-672	<u>C-RING</u>
13	P-596	<u>WASHER</u>
14	P-471	<u>LOCK NUT</u>
15	P-36257	<u>OPERATING LINK</u> - FOR 360 PRO INK "METERING" SYSTEM. ATTACHES TO ITEM #19, PAGE 28.
16	P-613	<u>WASHER</u>
17	P-711	<u>RETAINING RING</u>
18	P-36259	<u>RATCHET LEVER</u> - (11 POSITION) SEE ITEM #53, PAGE 47.
19	P-6007	<u>SPRING ANCHOR</u>
20	P-8011	<u>SHOULDER SCREW</u>
21	P-36965	<u>SPRING</u>
22	P-36355	<u>RATCHET LOCK</u>
23	P-487	<u>NUT</u>
24	P-36263	<u>RATCHET EXTENSION</u> - GOES THROUGH ITEM #18, THIS PAGE.
25	P-429	<u>TAPER PIN</u>
25A	P-36239	<u>RATCHET</u> - IF PURCHASED SEPARATELY, USE TAPER PIN P-430, REAMER P-1547 & REAMER TOOL P-1546.
26	P-36260	<u>ROLLER BEARING</u> - NON-OPERATORS SIDE. INCLUDES ITEM #11, THIS PAGE
27	P-36261	<u>SHIM</u>
28	P-36262	<u>ROLLER SEAL</u>
29	P-36765	<u>INK FOUNTAIN ROLLER</u>
30	P-36946	<u>SCREW</u>
31	P-36273	<u>ROLLER BEARING</u> - OPERATORS SIDE. 360 PRO - FOR 11 POSITION OLD DESIGN.
	P-36275	<u>ROLLER BEARING</u> - OPERATORS SIDE.
32	P-1225	<u>BUSHING</u>
33	P-1222	<u>BUSHING</u>
34	P-36097	<u>INK FOUNTAIN ASSEMBLY</u> - 360 PRO. A.B.DICK STYLE. (COMPLETE). SEE NOTE AT BOTTOM OF PAGE.
35	P-36091	<u>INK FOUNTAIN</u> - (ONLY) NOT AVAILABLE SEPARATELY AT THIS TIME.
36	P-8014	<u>SHOULDER SCREW</u>
37	P-36227	<u>MID SECTION</u> - NOT AVAILABLE SEPARATELY AT THIS TIME.
38	P-36226	<u>END CAP</u> - SOLD SEPARATELY. SAME FOR OPERATORS OR NON-OPERATORS SIDE.
39	P-82	<u>SCREW</u>
40	P-36095	<u>INK BLADE</u>
41	P-4400	<u>TENSION WIRE</u>
42	P-1570	<u>INK FOUNTAIN ADJUSTING SCREW</u> - 2-1/4" LONG.
43	P-471	<u>NUT</u>
44	P-1546	<u>REAMER TOOL</u>
45	P-1547	<u>REAMER</u>
46	P-36281	<u>INK FOUNTAIN ASSEMBLY &amp; ROLLER KIT</u> - 360 PRO - NOT ILLUSTRATED, INCLUDES ITEMS #29, #34 & #28 THIS PAGE. (SEE NOTE).
47	P-36805	<u>INK FOUNTAIN ASSEMBLY</u> - 360 PRO. OUR STYLE. (COMPLETE)
48	P-36807	<u>INK FOUNTAIN</u> - (ONLY).
49	P-98792	<u>END CAP</u> - SAME FOR OPERATORS SIDE AND NON-OPERATORS SIDE.
50	P-36795	<u>MID-SECTION</u>
51	P-262	<u>SCREW</u>
52	P-118	<u>SCREW</u>
53	P-36082	<u>BLADE CLAMP</u>
54	P-36233	<u>BLADE</u>
55	P-36084	<u>TENSION WIRE</u>
56	P-1570	<u>INK FOUNTAIN ADJUSTING SCREW</u>

**NOTE:** When replacing ink fountains keep in mind that a worn ink fountain roller may cause leakage on the sides of the fountain. To eliminate this problem we offer you a kit that includes an ink fountain assembly (item #34, this page) a new fountain roller (item #29, this page) & 2 roller seals (item #28 this page). SEE ITEM #46.

**DRAWING #29C**  
**INK FOUNTAIN (METERING) UNIT - 9800**

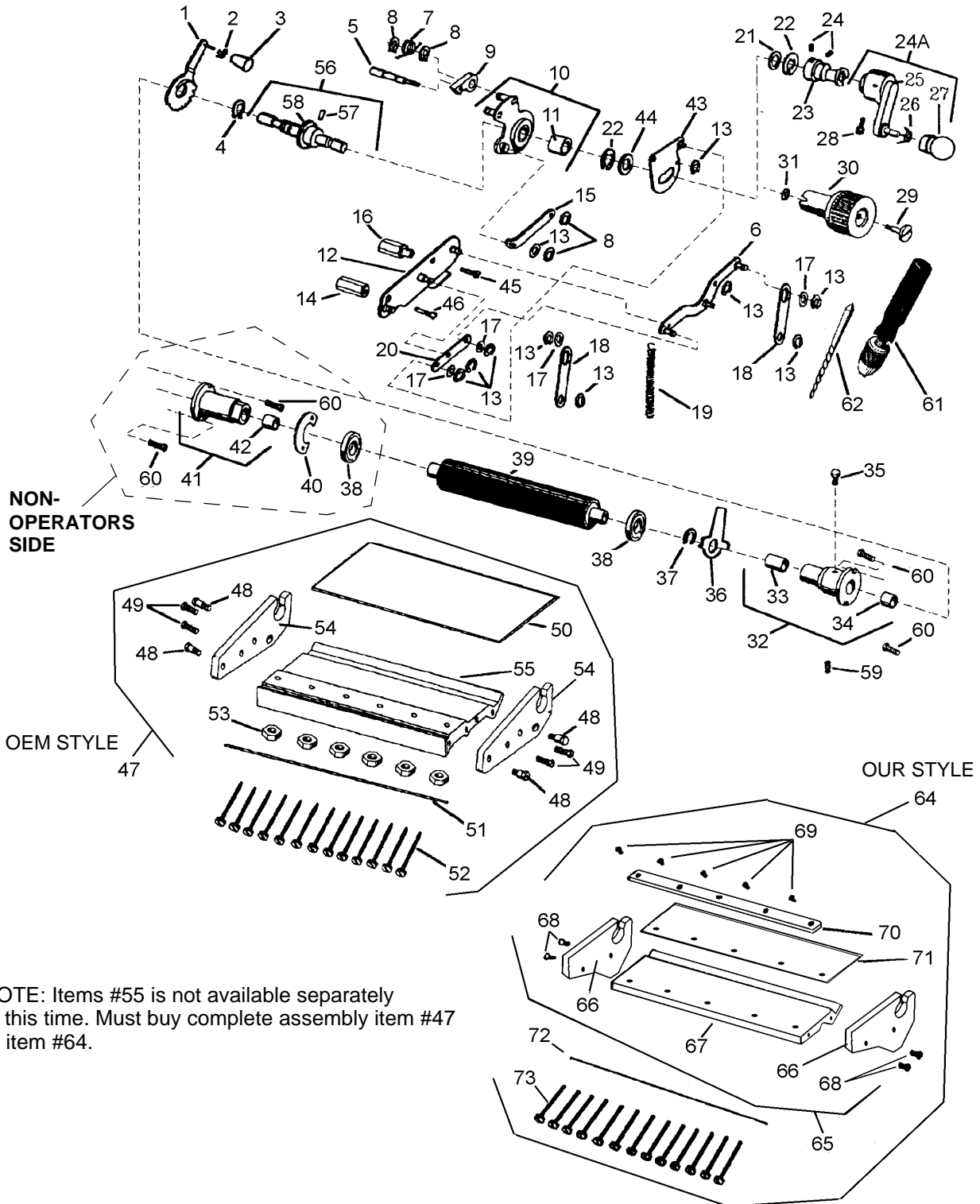

**PAGE #29C**  
**INK FOUNTAIN (METERING) UNIT - 9800**

KEY #	PART#	DESCRIPTION
1	P-98259	<u>RATCHET LEVER</u> - 11 POSITION, 9800 ONLY.
2	P-36410	<u>LOCK SPRING</u>
3	P-36062	<u>ALUMINUM HANDLE</u>
4	P-711	<u>RETAINING RING</u>
5	P-3010	<u>PAWL DEFLECTOR PIN</u>
6	P-98897	<u>LEVER ASSEMBLY</u>
7	P-36248	<u>SPRING</u>
8	P-700	<u>RETAINING RING</u>
9	P-98251	<u>PAWL</u>
10	P-98362	<u>LEVER ASSEMBLY</u>
11	P-1219	<u>BUSHING</u>
12	P-98312	<u>BRACKET</u>
13	P-667	<u>C-RING</u>
14	P-7022	<u>STUD</u>
15	P-36257	<u>OPERATING LINK</u> - ATTACHES TO ITEM #19 PAGE 28.
16	P-7021	<u>STUD</u>
17	P-577	<u>WASHER</u>
18	P-98288	<u>LINK</u>
19	P-98264	<u>SPRING</u>
20	P-98309	<u>LEVER</u>
21	P-617	<u>WASHER</u>
22	P-672	<u>C-RING</u>
23	P-98125	<u>RATCHET</u>
24	P-25	<u>SET SCREW</u>
24A	P-98402	<u>INK FOUNTAIN HAND CRANK ASSEMBLY</u> - QP, QPC & PRO.
25	P-98403	<u>INK FOUNTAIN HAND CRANK ONLY</u> - QP, QPC & PRO.
26	P-36959	<u>LOCK SPRING</u>
27	P-36062	<u>HANDLE</u>
28	P-43	<u>SCREW</u>
29	P-8056	<u>SHOULDER SCREW</u>
30	P-98242	<u>INK FOUNTAIN KNOB</u> - TRAY DELIVERY & CHAIN DELIVERY.
31	P-1495	<u>VINYL SPACER</u>
32	P-36273	<u>HOUSING ASSEMBLY</u> - OPERATORS SIDE. INK FOUNTAIN ROLLER.
33	P-1225	<u>BUSHING</u>
34	P-1222	<u>BUSHING</u>
35	P-36946	<u>SCREW</u>
36	P-98322	<u>LOCK OUT LEVER</u> - FOR INK DUCTOR, ITEM #47 PAGE 28.
37	P-1753	<u>CRESCENT RING</u>
38	P-36262	<u>ROLLER SEAL</u>
39	P-98035	<u>INK FOUNTAIN ROLLER</u>
40	P-36261	<u>BUSHING SHIM</u>
41	P-36260	<u>HOUSING ASSEMBLY</u> - NON-OPERATORS SIDE. INK FOUNTAIN ROLLER.
42	P-1221	<u>BUSHING</u>
43	P-98865	<u>PLATE</u>
44	P-617	<u>WASHER</u>
45	P-124	<u>SCREW</u>
46	P-272	<u>SCREW</u>
47	P-98097	<u>INK FOUNTAIN ASSEMBLY (METERING)</u> - 9800. <i>SEE NOTE AT BOTTOM OF PAGE.</i>
48	P-8014	<u>SHOULDER SCREW</u>
49	P-82	<u>SCREW</u>
50	P-98095	<u>BLADE</u>
51	P-37084	<u>WIRE</u>
52	P-1571	<u>SCREW</u>
53	P-471	<u>NUT</u>
54	P-36226	<u>END CAP</u> - SOLD SEPARATELY. SAME FOR OPERATORS & NON-OPERATORS SIDE.
55	P-98227	<u>MID-SECTION</u> - NOT AVAILABLE SEPARATELY AT THIS TIME.
56	P-98263	<u>RATCHET EXTENSION</u>
57	P-429	<u>TAPER PIN</u>
58	P-36239	<u>RATCHET</u> - IF PURCHASED SEPARATELY USE TAPER PIN P-430, REAMER P-1547 & REAMER TOOL P-1546.
59	P-8	<u>SET SCREW</u>
60	P-257	<u>SCREW</u> - FOR MOUNTING HOUSINGS ITEMS #32 & #41 THIS PAGE.
61	P-1546	<u>REAMER TOOL</u>
62	P-1547	<u>REAMER BIT</u>
63	P-98279	<u>INK FOUNTAIN ASSEMBLY &amp; ROLLER KIT</u> - 9800 TRAY DEL. & CHAIN DEL. NOT ILLUSTRATED... <i>SEE NOTE.</i>
64	P-98805	<u>INK FOUNTAIN ASSEMBLY</u> - 9800 PRO. OUR STYLE. (COMPLETE)
65	P-98807	<u>INK FOUNTAIN</u> - (ONLY).
66	P-98792	<u>END CAP</u> - SAME FOR OPERATORS SIDE AND NON-OPERATORS SIDE.
67	P-37795	<u>MID-SECTION</u>
68	P-262	<u>SCREW</u>
69	P-118	<u>SCREW</u>
70	P-37082	<u>BLADE CLAMP</u>
71	P-37233	<u>BLADE</u>
72	P-37084	<u>TENSION WIRE</u>
73	P-1570	<u>INK FOUNTAIN ADJUSTING SCREW</u>
		 <b>NOTE:</b> When replacing ink fountains keep in mind that a worn ink fountain roller may cause leakage on the edges of the fountain. To eliminate this problem we offer you a kit that includes an ink fountain assembly (item #47 & a new fountain roller #39 & 2 roller seals #38, this page.

**DRAWING #30**  
**ROLLER KITS**

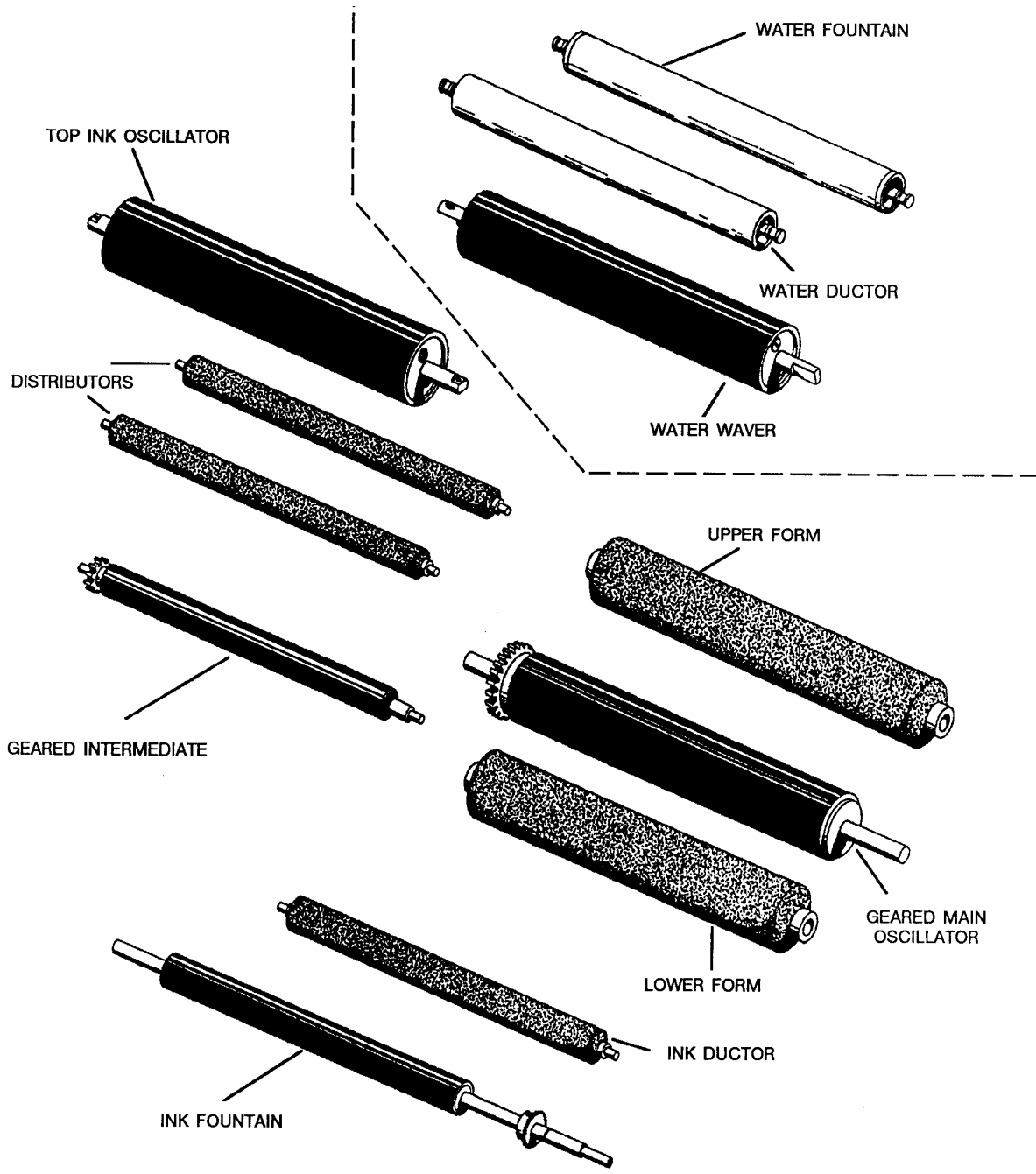

FOR LOCATIONS OF ROLLERS SEE PAGE 27



INDICATES METAL ROLLER



INDICATES HARD RUBBER



INDICATES SOFT RUBBER



**PAGE #30**  
**ROLLER KITS - (CONTINUES ON NEXT PAGE)**

KEY #	PART#	DESCRIPTION
1	P-5001	<u>SOFT RUBBER INK ROLLER KIT - 360 OLD STYLE</u> CONSISTS OF 5 ROLLERS 1 EA. P-36030 DUCTOR 2 EA. P-36021 DISTRIBUTOR 2 EA. P-36010 UPPER FORM
	P-5021	<u>SOFT RUBBER INK ROLLER KIT - 375/9800</u> CONSISTS OF 5 ROLLERS 1 EA. P-37030 DUCTOR 2 EA. P-37021 DISTRIBUTOR 1 EA. P-37010 UPPER FORM 1 EA. P-37011 LOWER FORM
2	P-5002	<u>COMPLETE INK ROLLER KIT - 360 OLD STYLE</u> CONSISTS OF 9 ROLLERS 1 EA. P-36030 DUCTOR 2 EA. P-36021 DISTRIBUTOR 2 EA. P-36010 UPPER FORM 1 EA. P-36035 FOUNTAIN 1 EA. P-36029 INTERMEDIATE 1 EA. P-360820 TOP OSCILLATOR 1 EA. P-360830 GEARED MAIN OSCILLATOR
3	P-5003	<u>COMPLETE INK &amp; WATER ROLLER KIT - 360 OLD STYLE</u> CONSISTS OF 12 ROLLERS 1 EA. P-5002 COMPLETE INK ROLLER KIT 1 EA. P-5007 COMPLETE WATER ROLLER KIT
4	P-5004	<u>SOFT RUBBER INK ROLLER KIT - 360 NEW STYLE</u> CONSISTS OF 5 ROLLERS 1 EA. P-36030 DUCTOR 2 EA. P-36021 DISTRIBUTOR 1 EA. P-36011 LOWER FORM 1 EA. P-36010 UPPER FORM
5	P-5005	<u>HARD RUBBER INK ROLLER KIT - 360 OLD &amp; NEW STYLE</u> CONSISTS OF 4 ROLLERS 1 EA. P-36035 FOUNTAIN 1 EA. P-36029 INTERMEDIATE 1 EA. P-360820 TOP OSCILLATOR 1 EA. P-360830 GEARED MAIN OSCILLATOR
	P-5022	<u>HARD RUBBER INK ROLLER KIT - 375/9800</u> CONSISTS OF 4 ROLLERS 1 EA. P-37035 FOUNTAIN 1 EA. P-37029 INTERMEDIATE 1 EA. P-370820 TOP OSCILLATOR 1 EA. P-370830 GEARED MAIN OSCILLATOR
6	P-5006	<u>COMPLETE INK ROLLER KIT - 360 NEW STYLE</u> CONSISTS OF 9 ROLLERS 1 EA. P-5004 SOFT RUBBER ROLLER KIT 1 EA. P-5005 HARD RUBBER ROLLER KIT
	P-5019	<u>COMPLETE INK ROLLER KIT - 375/9800</u> CONSISTS OF 9 ROLLERS 1 EA. P-5021 SOFT RUBBER ROLLER KIT 1 EA. P-5022 HARD RUBBER ROLLER KIT
7	P-5007	<u>COMPLETE WATER ROLLER KIT - 360 OLD &amp; NEW STYLE</u> CONSISTS OF 3 ROLLERS 1 EA. P-360850 OSCILLATING WAVER 1 EA. P-36050 DUCTOR 1 EA. P-36364 FOUNTAIN
8	P-5008	<u>COMPLETE INK &amp; WATER ROLLER KIT - 360 NEW STYLE</u> CONSISTS OF 12 ROLLERS 1 EA. P-5006 COMPLETE INK ROLLER KIT 1 EA. P-5007 COMPLETE WATER ROLLER KIT
9	P-5009	<u>SOFT RUBBER INK ROLLER KIT - 350 OLD STYLE</u> CONSISTS OF 5 ROLLERS 1 EA. P-35030 DUCTOR 2 EA. P-35021 DISTRIBUTOR 2 EA. P-35010 UPPER FORM

**DRAWING #30A**  
**ROLLER KITS**

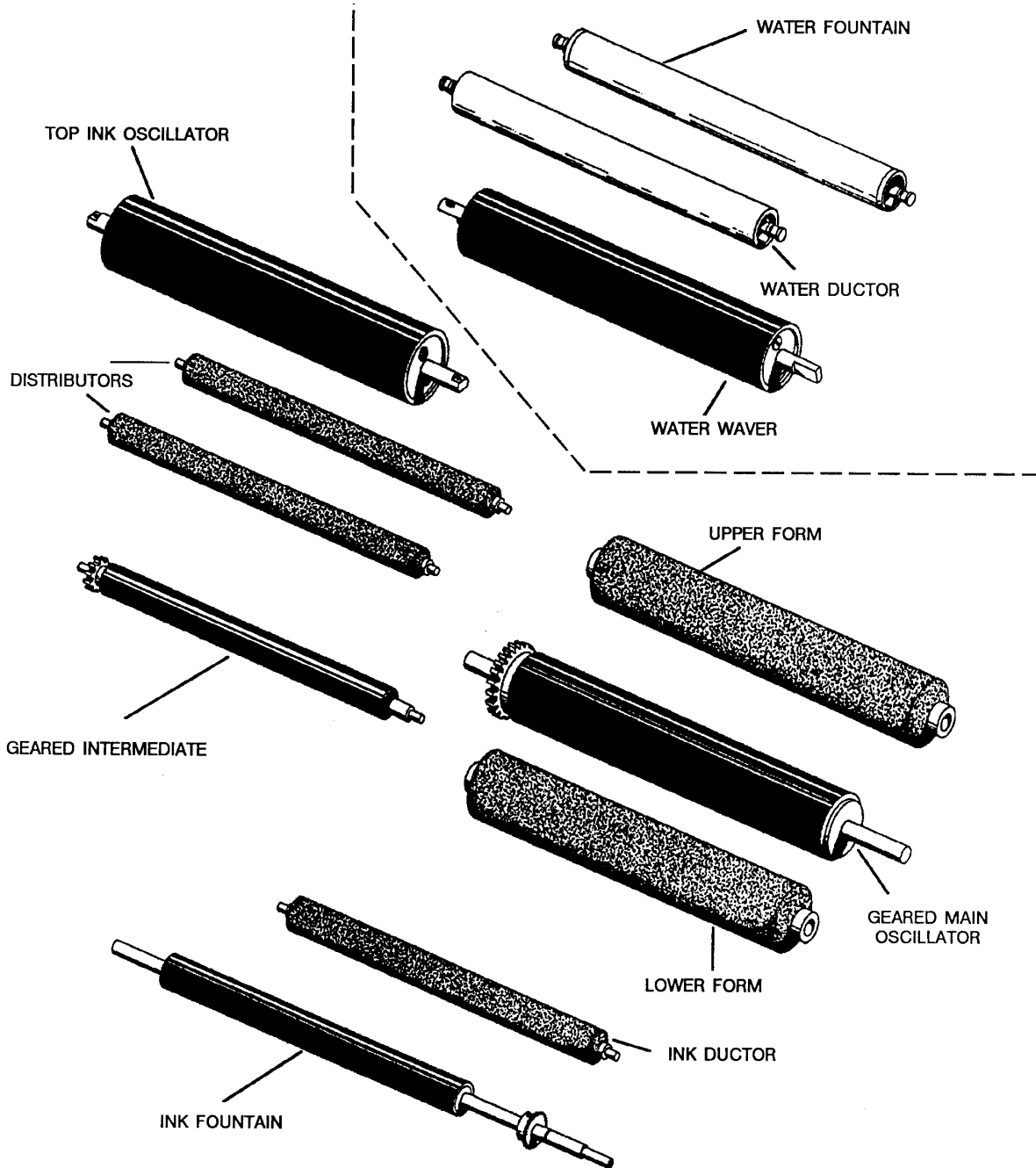

FOR LOCATIONS OF ROLLERS SEE PAGE 27

○ INDICATES METAL ROLLER

● INDICATES HARD RUBBER

⊙ INDICATES SOFT RUBBER

**PAGE #30A**  
**ROLLER KITS - (CONTINUED FROM LAST PAGE)**

KEY #	PART#	DESCRIPTION
10	P-5010	<u>HARD RUBBER INK ROLLER KIT - 350 OLD STYLE</u> CONSISTS OF 4 ROLLERS 1 EA. P-35035 FOUNTAIN 1 EA. P-35029 INTERMEDIATE 1 EA. P-350820 TOP OSCILLATOR 1 EA. P-350830 GEARED MAIN OSCILLATOR
11	P-5011	<u>COMPLETE INK ROLLER KIT - 350 OLD STYLE</u> CONSISTS OF 9 ROLLERS 1 EA. P-5009 SOFT RUBBER ROLLER KIT 1 EA. P-5010 HARD RUBBER ROLLER KIT
12	P-5012	<u>COMPLETE WATER ROLLER KIT - 350 OLD &amp; NEW STYLE</u> CONSISTS OF 3 ROLLERS 1 EA. P-350850 WAVER OSCILLATOR 1 EA. P-35050 DUCTOR 1 EA. P-36364 FOUNTAIN
	P-5020	<u>COMPLETE WATER ROLLER KIT - 375/9800</u> CONSISTS OF 3 ROLLERS 1 EA. P-370850 WAVER OSCILLATOR 1 EA. P-37080 DUCTOR 1 EA. P-37364 FOUNTAIN
13	P-5013	<u>SOFT RUBBER INK ROLLER KIT - 350 NEW STYLE</u> CONSISTS OF 5 ROLLERS 1 EA. P-35030 DUCTOR 2 EA. P-35021 DISTRIBUTOR 1 EA. P-35010 UPPER FORM 1 EA. P-35011 LOWER FORM
14	P-5014	<u>HARD RUBBER INK ROLLER KIT - 350 NEW STYLE</u> CONSISTS OF 4 ROLLERS 1 EA. P-35035 FOUNTAIN 1 EA. P-35029 INTERMEDIATE 1 EA. P-350820 TOP OSCILLATOR 1 EA. P-350830 GEARED MAIN OSCILLATOR
15	P-5015	<u>COMPLETE INK ROLLER KIT - 350 NEW STYLE</u> CONSISTS OF 9 ROLLERS 1 EA. P-5013 SOFT RUBBER INK ROLLER KIT 1 EA. P-5014 HARD RUBBER ROLLER KIT
16	P-5016	<u>COMPLETE INK &amp; WATER ROLLER KIT - 350 OLD STYLE</u> CONSISTS OF 12 ROLLERS 1 EA. P-5009 SOFT RUBBER ROLLER KIT 1 EA. P-5010 HARD RUBBER ROLLER KIT 1 EA. P-5012 COMPLETE WATER ROLLER KIT
17	P-5017	<u>COMPLETE INK &amp; WATER ROLLER KIT - 350 NEW STYLE</u> CONSISTS OF 12 ROLLERS 1 EA. P-5012 COMPLETE WATER ROLLER KIT 1 EA. P-5013 SOFT RUBBER ROLLER KIT 1 EA. P-5014 HARD RUBBER ROLLER KIT
18	P-5018	<u>COMPLETE INK WATER ROLLER KIT - 375/9800</u> CONSISTS OF 12 ROLLERS 1 EA. P-5020 COMPLETE WATER ROLLER KIT 1 EA. P-5021 SOFT RUBBER ROLLER KIT 1 EA. P-5022 HARD RUBBER ROLLER KIT

**DRAWING #31**  
**UPPER EJECTOR ROLLER ASSEMBLY - (CHUTE DELIVERY)**

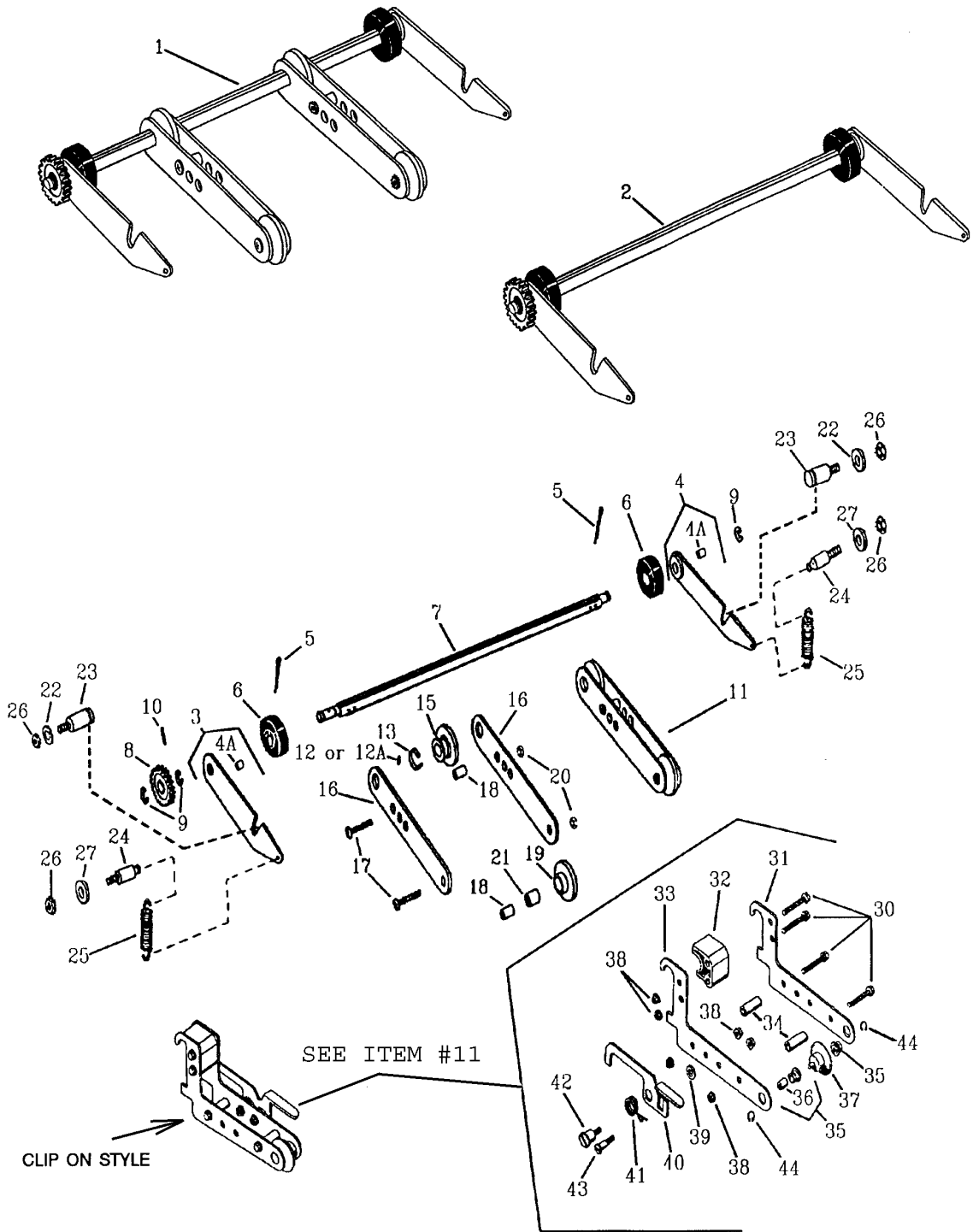

**PAGE #31**  
**UPPER EJECTOR ROLLER ASSEMBLY - (CHUTE DELIVERY)**

KEY #	PART#	DESCRIPTION
1	P-36616 P-37616	<u>GEAR DRIVEN EJECTOR ROLLER ASSEMBLY</u> - COMPLETE ASSEMBLY AS SHOWN. ADJUSTABLE TO 350 - 360. <u>GEAR DRIVEN EJECTOR ROLLER ASSEMBLY</u> - COMPLETE ASSEMBLY AS SHOWN. 375/9800
2	P-36582 P-37582	<u>ADJUSTABLE ROLLER ASSEMBLY</u> - AS SHOWN. ADJUSTABLE TO 350 - 360. ITEMS #3 THRU #10, THIS PAGE. <u>ADJUSTABLE ROLLER ASSEMBLY</u> - AS SHOWN. 375/9800. ITEMS #3 THRU #10, THIS PAGE.
3	P-36586	<u>ARM</u> - NON-OPERATOR SIDE.
4	P-36584	<u>ARM</u> - OPERATOR SIDE.
4A	P-802	<u>BUSHING</u>
5	P-342	<u>COTTER PIN</u>
6	P-36590	<u>HOLD DOWN ROLLER</u>
7	P-36594 P-37594	<u>SHAFT</u> - "UNIVERSAL" (BY MOVING COTTER PINS AND ROLLERS YOU CAN ADJUST TO 350 OR 360). <u>SHAFT</u>
8	P-36596	<u>GEAR</u> - RUNS WITH ITEM #10, PAGE 12.
9	P-668	<u>C-RING</u>
10	P-373	<u>ROLL PIN</u>
11	P-36602	<u>EJECTOR ROLLER ARM KIT</u> - SLIDES ON SHAFT - NOT CLIP ON STYLE ( <i>SEE NOTE</i> ).
12	P-839	<u>FRICITION PIN</u> - 5/16" LONG. USE WITH P-36588 ITEM #13.
12A	P-1507	<u>FRICITION PIN</u> - 3/8" LONG USE WITH P-36608 ITEM #13.
13	P-36588 P-36608	<u>CLIP</u> - 3/4" O.D. USE WITH P-839 ITEM #12. <u>CLIP</u> - 15/16" O.D. OLD STYLE. USE WITH P-1507 ITEM #12A.
15	P-36592	<u>ADJUSTABLE ROLLER</u>
16	P-36598	<u>ARM</u> - CONTAINS 2.
17	P-220	<u>SCREW</u>
18	P-1403	<u>SPACER</u> - SLEEVE.
19	P-36600	<u>LOWER ROLLER</u>
20	P-471	<u>KEPS NUT</u>
21	P-773	<u>BEARING</u>
22	P-592	<u>SPACER</u>
23	P-6019	<u>CRADLE ARM PIVOT</u>
24	P-6016 P-6017 P-6018	<u>SPRING ANCHOR</u> <u>SPRING ANCHOR</u> - 369 OPERATORS SIDE. <u>SPRING ANCHOR</u> - 369 NON-OPERATORS SIDE.
25	P-36604	<u>TENSION SPRING</u>
26	P-487	<u>NUT</u>
27	P-598	<u>WASHER</u>
30	P-85	<u>SCREW</u>
31	P-36611	<u>ARM</u> - OPERATORS SIDE.
32	P-36614	<u>SUPPORT BLOCK</u>
33	P-36612	<u>ARM</u> - NON-OPERATORS SIDE.
34	P-1404	<u>SPACER</u> - SLEEVE.
35	P-36613	<u>BEARING HUB</u>
36	P-1331	<u>BUSHING</u>
37	P-36621	<u>ROLLER</u>
38	P-472	<u>NUT</u>
39	P-570	<u>WASHER</u> - SPACER.
40	P-36607 P-36609	<u>HOLD DOWN LATCH LEVER</u> - NON-OPERATORS SIDE. <u>HOLD DOWN LATCH LEVER</u> - OPERATORS SIDE.
41	P-36620 P-36618	<u>SPRING</u> - NON-OPERATORS SIDE. <u>SPRING</u> - OPERATORS SIDE.
42	P-8018	<u>SHOULDER SCREW</u>
43	P-8014	<u>SHOULDER SCREW</u>
44	P-716	<u>RETAINING RING</u>

**NOTE: "CLIP ON" ARM IS NOT AVAILABLE AS AN ASSEMBLY. INDIVIDUAL PARTS ARE AVAILABLE.  
"SLIDE ON" ARM IS AVAILABLE AS AN ASSEMBLY.**

**DRAWING #32**  
**LOWER EJECTOR ROLLER ASSEMBLY - (CHUTE DELIVERY)**

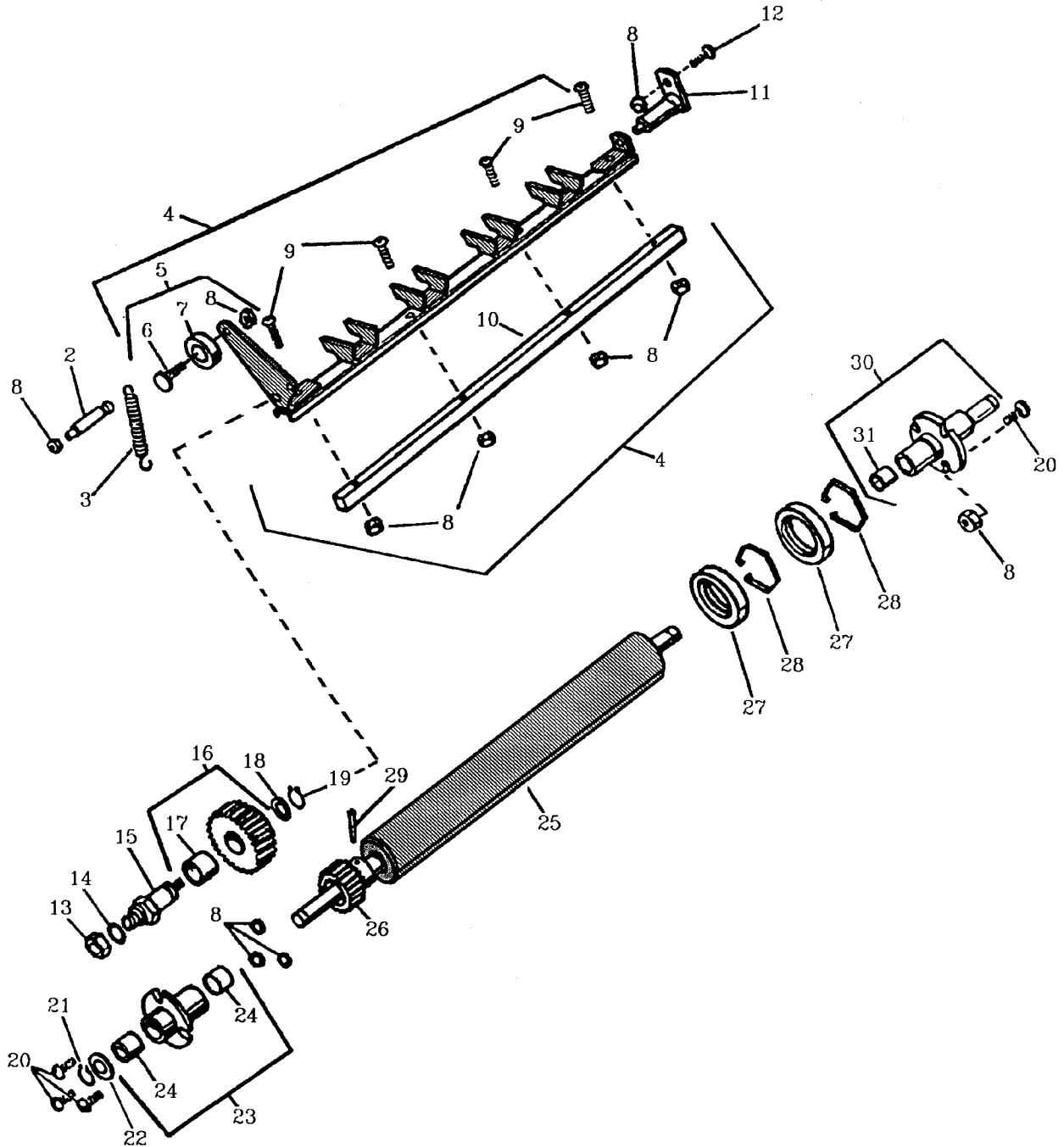

**PAGE #32**  
**LOWER EJECTOR ROLLER & STRIPPER ASSEMBLY - (CHUTE DELIVERY)**

KEY #	PART#	DESCRIPTION
2	P-6020	<u>SPRING ANCHOR</u> - MOUNTS TO INSIDE NON-OPERATORS SIDE FRAME. 360 - 369
3	P-36574	<u>TENSION SPRING</u> - CONNECTS TO ITEM #2 & ITEM #4 THIS PAGE.
4	P-36558	<u>STRIPPER CHANNEL ASSEMBLY</u> - ITEMS #5,#6,#7,#8,#9 & #10.
5	P-36622	<u>STRIPPER CHANNEL &amp; CAM ASSEMBLY</u>
	P-37622	<u>STRIPPER CHANNEL &amp; CAM ASSEMBLY</u>
6	P-1600	<u>SCREW &amp; NUT</u> - NUT IS ITEM #8, THIS PAGE. P-471 (OPTIONAL - FOR REPLACEMENT ONLY)
	P-319	<u>RIVET</u> - COMES WITH COMPLETE ASSEMBLY
7	P-765	<u>BEARING</u> - (CAM)
8	P-471	<u>NUT</u>
9	P-267	<u>SCREW</u>
10	P-36626	<u>STRIPPER CHANNEL SUPPORT BAR</u>
	P-37626	<u>STRIPPER CHANNEL SUPPORT BAR</u>
11	P-36628	<u>PIVOT</u> - GOES THROUGH SIDE FRAME (OPERATORS SIDE)
12	P-263	<u>SCREW</u>
13	P-500	<u>NUT</u>
14	P-634	<u>LOCKWASHER</u>
15	P-36630	<u>IDLER GEAR STUD</u> - MOUNTS INSIDE OF SIDE FRAME AND STRIPPER CHANNEL, ITEM #4, THIS PAGE.
16	P-36632	<u>IDLER GEAR ASSEMBLY</u> - OPERATED BY GEAR ITEM #10, PAGE 12 & OPERATES ITEM #26, THIS PAGE.
17	P-1222	<u>BUSHING</u>
18	P-614	<u>WASHER</u>
19	P-705	<u>RETAINING RING</u>
20	P-936	<u>SCREW</u> - (NEW STYLE) HEX HEAD
	P-263	<u>SCREW</u> - PHILLIPS HEAD
21	P-703	<u>RETAINING RING</u>
22	P-604	<u>WASHER</u>
23	P-36640	<u>HOUSING ASSEMBLY</u>
24	P-822	<u>BUSHING</u>
25	P-36634	<u>DELIVERY ROLLER &amp; GEAR</u>
	P-37634	<u>DELIVERY ROLLER &amp; GEAR</u>
26	P-36636	<u>GEAR</u> - OPERATED BY ITEM #16, THIS PAGE & OPERATES GEAR ITEM #23, PAGE 44.
	P-38636	<u>GEAR</u> - OPERATED BY GEAR ITEM #16, THIS PAGE & OPERATES GEAR ITEM #23 PAGE 44.
27	P-36642	<u>ADJUSTABLE COLLAR</u> - SLIDES ONTO ROLLER #25, THIS PAGE. #19 PAGE 31 RIDES ON THESE COLLARS.
28	P-36644	<u>FRICTION SPRING</u> - FITS INTO COLLAR ITEM #27, THIS PAGE.
29	P-382	<u>ROLL PIN</u>
30	P-36646	<u>STUD ASSEMBLY</u> - FOR CHUTE DELIVERY
	P-36638	<u>STUD ASSEMBLY</u> - FOR CHAIN DELIVERY
31	P-822	<u>BUSHING</u>

**DRAWING #33**  
**RECEIVING TRAY ASSEMBLY - (CHUTE DELIVERY)**

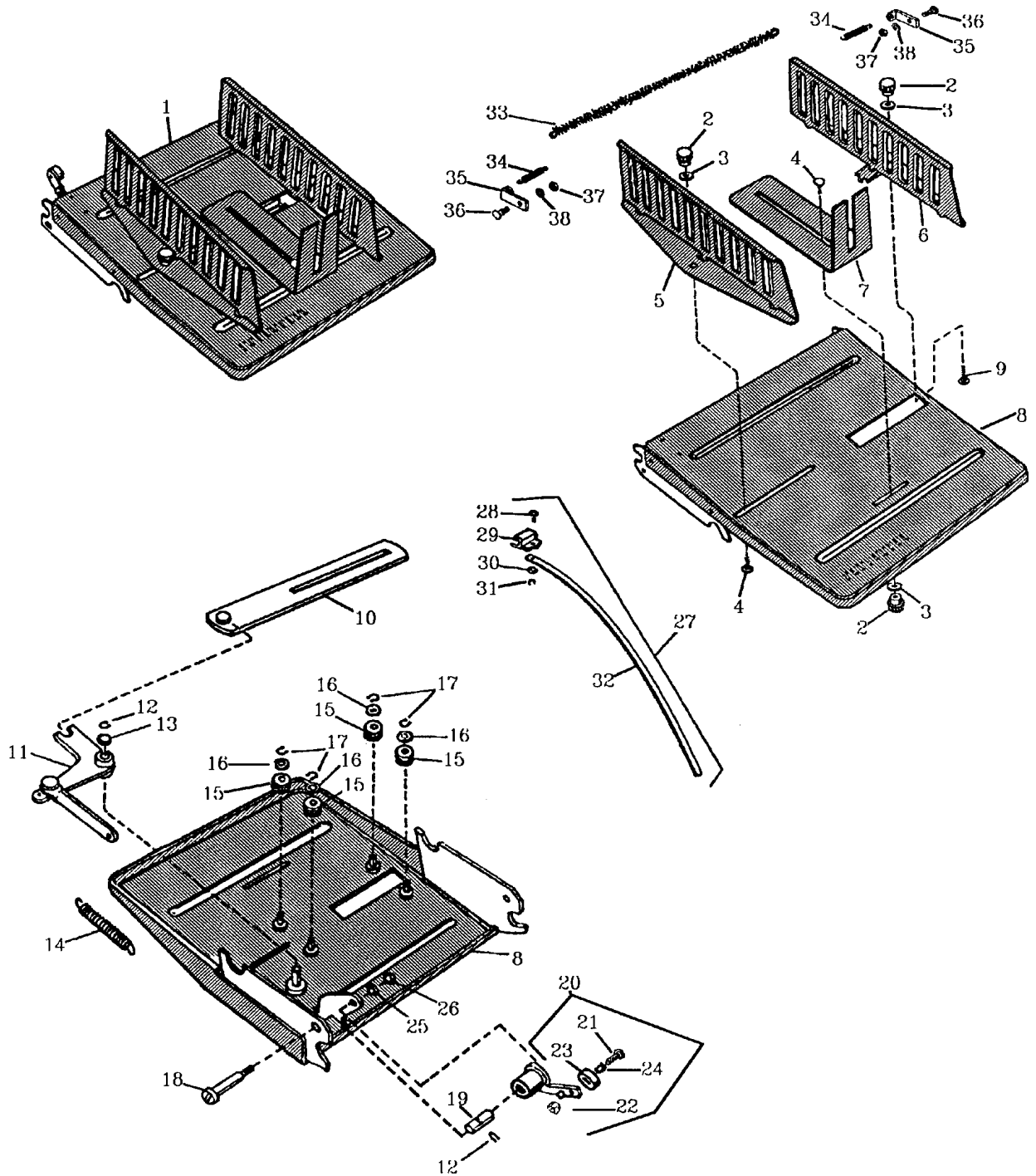



**PAGE #33**  
**RECEIVING TRAY ASSEMBLY - (CHUTE DELIVERY)**

KEY #	PART#	DESCRIPTION
1	P-36670	<u>RECEIVING TRAY ASSEMBLY</u> - RESTS ON TIE BAR, ITEM #11, PAGE 49.
	P-37670	<u>RECEIVING TRAY ASSEMBLY</u> - RESTS ON TIE BAR, ITEM #11, PAGE 49.
2	P-541	<u>KNOB</u> - 3 PER ASSEMBLY
3	P-1055	<u>WASHER</u>
	P-105	<u>SCREW</u>
5	P-36672	<u>PAPER GUIDE ASSEMBLY</u> - FOR NON-OPERATORS SIDE.
6	P-36674	<u>PAPER GUIDE ASSEMBLY</u> - FOR OPERATORS SIDE.
7	P-36676	<u>PAPER BACK STOP</u>
8	P-36648	<u>RECEIVING TRAY</u>
	P-37648	<u>RECEIVING TRAY</u>
9	P-107	<u>SCREW</u> - ATTACHES TO ITEM #6, P-36674 THIS PAGE.
10	P-36678	<u>SLIDE</u> - 350/360
	P-37678	<u>SLIDE</u> - 375/9800
11	P-36650	<u>CRANK &amp; LINK ASSEMBLY</u>
12	P-703	<u>RETAINING RING</u>
13	P-603	<u>WASHER</u>
14	P-36660	<u>SPRING</u>
15	P-36680	<u>CAM</u>
16	P-586	<u>WASHER</u>
17	P-698	<u>RETAINING RING</u>
18	P-36682	<u>SCREW</u>
19	P-36652	<u>BUSHING</u>
20	P-36656	<u>CAM ROLLER &amp; LEVER ASSEMBLY</u> - OPERATES WITH CAM ITEM #30, PAGE 44.
21	P-1600	<u>SCREW &amp; NUT ASSEMBLY</u> - INCLUDES ITEM #22, P-471 THIS PAGE.
22	P-471	<u>NUT</u>
23	P-1455	<u>CAM ROLLER</u>
24	P-1379	<u>BUSHING</u>
25	P-570	<u>WASHER</u>
26	P-469	<u>NUT</u>
27	P-36662	<u>TRAY BAIL ASSEMBLY</u> - (PAPER RETAINER ASSEMBLY) - CLIPS ONTO ITEM #27, PAGE 46.
28	P-36664	<u>STUD</u>
29	P-36666	<u>BRACKET</u>
30	P-559	<u>WASHER</u>
31	P-661	<u>SNAP RING</u>
32	P-36668	<u>TRAY BAIL</u> - (PAPER RETAINER)
33	P-36502	<u>TINSEL</u> - READY TO HANG BETWEEN SPRINGS ITEM #34, THIS PAGE.
	P-36658	<u>TINSEL</u> - SOLD AS 10 FT. LENGTHS.
	P-36654	<u>TINSEL</u> - SOLD AS 1 FT. LENGTHS.
	P-36673	<u>TINSEL</u> - SOLD AS 72 FT. LENGTHS.
34	P-35257	<u>SPRING</u>
35	P-36657	<u>SPRING CLIP BRACKET</u> - ATTACHES TO SIDE FRAME BEHIND EJECTOR ROLLER.
36	P-105	<u>SCREW</u>
37	P-478	<u>NUT</u>
38	P-635	<u>WASHER</u>

**DRAWING #34**  
**DRIVE SHAFT & CLUTCH PULLEY ASSEMBLY**

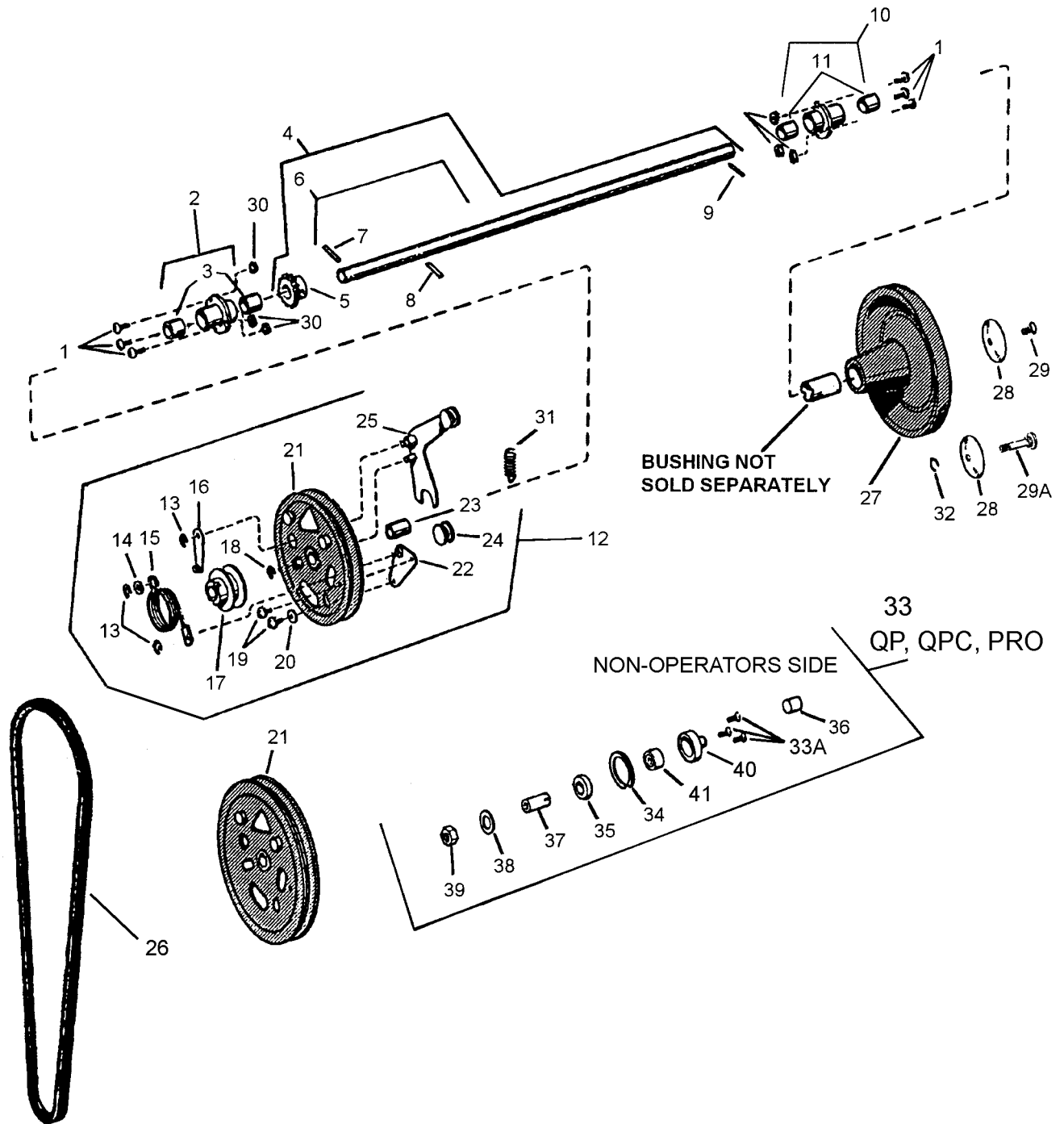

**PAGE #34**  
**DRIVE SHAFT & CLUTCH PULLEY ASSEMBLY**

KEY #	PART#	DESCRIPTION
1	P-263	<u>SCREW</u>
2	P-36487	<u>HOUSING ASSEMBLY</u> - N.O.S. 1/2" SHAFT - 350, 360. SEE ITEM #33 AND RELATED PARTS ON THIS PAGE FOR 9800 QPC, QP & PRO.
	P-37487	<u>HOUSING ASSEMBLY</u> - N.O.S. 1/2" SHAFT - 375 & 9800 TD & CD. SEE ITEM #33 AND RELATED PARTS ON THIS PAGE FOR 9800 QPC, QP & PRO.
3	P-1221	<u>BUSHING</u> - 350, 360, 369, 375. FOR 1/2" SHAFT.
	P-1237	<u>BUSHING</u> - 9805 - 9820. FOR 1/2" SHAFT. FITS BOTH SIDES OF SHAFT
4	P-36577	<u>DRIVE SHAFT &amp; GEAR ASSEMBLY</u> - DRIVE SHAFT, DRIVE GEAR & PINS P-401 & P-355.
5	P-36581	<u>DRIVE GEAR</u> - 350, 360 & 375. OPERATES GEAR ITEM #7 PAGE 13. (1/2" I.D.).
	P-38581	<u>DRIVE GEAR</u> - 9800 & 385. OPERATES GEAR ITEM #7 PAGE 13. (5/8" I.D.).
6	P-36583	<u>DRIVE SHAFT ASSEMBLY</u> - DRIVE SHAFT & ROLL PIN P-401. (1/2" O.D.).
	P-37583	<u>DRIVE SHAFT ASSEMBLY</u> - 375. (1/2" O.D.).
	P-98388	<u>DRIVE SHAFT</u> - 9800 QP, QPC & PRO. SHAFT ONLY - PIN NOT INCLUDED. THREADED AT ONE END. (5/8" O.D.).
	P-98583	<u>DRIVE SHAFT ASSEMBLY</u> - 9800. DRIVE SHAFT & ROLL PIN P-401. NOT THREADED. (1/2" O.D.).
7	P-401	<u>ROLL PIN</u> - FOR CLUTCH. 350, 360, 375.
	P-403	<u>ROLL PIN</u> - FOR CLUTCH. 9800 With 5/8" SHAFTS & 385.
8	P-355	<u>SPIRAL PIN</u> - FOR GEAR.
9	P-385	<u>ROLL PIN</u> - FOR HAND WHEEL.
	P-393	<u>ROLL PIN</u> - FOR HAND WHEEL, 9800 SHAFT ONLY.
10	P-36585	<u>HOUSING ASSEMBLY</u> - OPERATORS SIDE. 350, 360, 375. (1/2" I.D. WITH BUSHING).
	P-37585	<u>HOUSING ASSEMBLY</u> - OPERATORS SIDE. 375, 9800 O.S. (1/2" I.D. WITH BUSHING).
	P-98585	<u>HOUSING ASSEMBLY</u> - OPERATORS SIDE. 9800 QP, QPC, & PRO. (5/8" I.D. WITH SLEEVE).
11	P-1225	<u>BUSHING</u> - (NEED 1 ONLY FOR 1/2" INCH SHAFT.)
	P-1260	<u>BUSHING</u> - (NEED 1 PER HOUSING PLUS 1 OF P-1262 FOR 5/8" SHAFT.)
	P-1262	<u>BUSHING</u> - (NEED 1 PER HOUSING PLUS 1 OF P-1260 FOR 5/8" SHAFT.)
12	P-36597	<u>CLUTCH PULLEY ASSEMBLY</u> - 6" DIA. (REGULAR) (1/2" I.D. WITH BUSHING).
	P-36589	<u>CLUTCH PULLEY ASSEMBLY</u> - 8" DIA. (SPECIAL) FOR SLOWER SPEED CONTROL. USE BELT P-1693, #26. (1/2" I.D.).
	P-98597	<u>CLUTCH PULLEY ASSEMBLY</u> - 6" DIA. (REGULAR). (5/8" I.D. WITH BUSHING).
13	P-667	<u>C-RING</u>
14	P-577	<u>WASHER</u>
15	P-36591	<u>CLUTCH SPRING</u>
16	P-36593	<u>CLUTCH SPRINGLINK</u>
17	P-36595	<u>CLUTCH PINION SPRING HOLDER</u> - 350, 360 & 375.
	P-98595	<u>CLUTCH PINION SPRING HOLDER</u> - 9800.
18	P-669	<u>C-RING</u>
19	P-256	<u>SCREW</u>
20	P-569	<u>WASHER</u>
21	P-36587	<u>CLUTCH PULLEY ONLY</u> - 6" DIAMETER. (REGULAR).
	P-36599	<u>CLUTCH PULLEY ONLY</u> - 8" DIAMETER. (SPECIAL). FOR SLOWER SPEED CONTROL USE BELT P-1693.
	P-98587	<u>CLUTCH PULLEY ONLY</u> - 6" DIAMETER. (REGULAR).
22	P-36601	<u>SPRING ADJUSTMENT PLATE</u>
23	P-1223	<u>BUSHING</u> - 1/2" I.D.)
	P-1342	<u>BUSHING</u> - FOR P-98587. (5/8" I.D.)
24	P-36603	<u>WEIGHT</u>
25	P-36605	<u>LEVER</u>
26	P-1691	<u>50" DRIVE BELT</u> - 115V, 60Hz. (FOR 56 OR 56Z FRAME MOTORS) CHAIN DELIVERY, SEE ITEM #32, PAGE 1.
	P-1690	<u>49" DRIVE BELT</u> - 115V, 60Hz. (FOR 48 FRAME MOTORS) CHUTE DELIVERY, SEE ITEM #32, PAGE 1.
	P-1693	<u>53" DRIVE BELT</u> - FOR PRESSES WITH 8" DIAMETER PULLEY. SEE ITEM #3,2 PAGE 1.
	P-1692	<u>51" DRIVE BELT</u> - (230V, 50Hz.) SEE ITEM #32, PAGE 1.
	P-1694	<u>51" DRIVE BELT</u> - (115V, 60Hz.) SEE ITEM #51, PAGE 1A.
	P-4917	<u>50" DRIVE BELT</u> - CONNECTS TO ITEM #42 PAGE 1B.
27	P-36615	<u>HANDWHEEL</u> - (BUSHING FOR HANDWHEEL NOT AVAILABLE SEPARATELY).
	P-98615	<u>HANDWHEEL</u> - (BUSHING FOR HANDWHEEL NOT AVAILABLE SEPARATELY).
28	P-36617	<u>DISC</u> - 2" DIA. 350, 360, 375 & 385.
	P-98617	<u>DISC</u> - 4-1/2" DIA. 9800 ONLY.
29	P-1000	<u>SCREW</u>
29A	P-8047	<u>SHOULDER SCREW</u> - 15/16" LONG FOR 9800 QP, QPC & PRO. NEEDS RETAINING RING P- 685 ITEM #32.
	P-8048	<u>SHOULDER SCREW</u> - 9/16" LONG. NEEDS RETAINING RING P-685 ITEM #32.
30	P-471	<u>KEPS NUT</u>
31	P-35098	<u>SPRING</u> - USE WITH OLD STYLE CLUTCH PULLEY ONLY.
32	P-685	<u>RETAINING RING</u> - EXTERNAL. USE WITH ITEM #29 SCREW.
33	P-98385	<u>HOUSING ASSEMBLY</u> - COMPLETE FOR 9800 PRO. N.O.S.
33A	P-897	<u>SCREW</u>
34	P-1827	<u>RETAINING RING</u> - INTERNAL.
35	P-98390	<u>SPACER</u> - FOR 5/8" SHAFT.
36	P-98395	<u>SLEEVE</u> - QP, QPC & PRO. FOR 5/8" SHAFT.
37	P-98398	<u>SLEEVE</u> - FOR INSIDE OF P-98597. FOR 5/8" SHAFT.
38	P-613	<u>WASHER</u>
39	P-514	<u>NUT</u>
40	P-98487	<u>HOUSING ASSEMBLY</u> - N.O.S. - 9800 QPC, QP & PRO ONLY. SEE ITEM #2 THIS PAGE FOR 350, 360 & 375.
41	P-783	<u>BEARING</u> - FOR 5/8" SHAFT.

**NOTE:** OUR OVERSIZED CLUTCH PULLEY ALSO INCLUDES INSTALLATION INSTRUCTIONS AND ONE OF EACH;  
(53" DRIVE BELT P-1693, WASHER P-1800, SCREW P-1013)

**DRAWING #35**  
**BUCKLE ADJUSTING MECHANISM & COUNTER OPERATING LEVER**

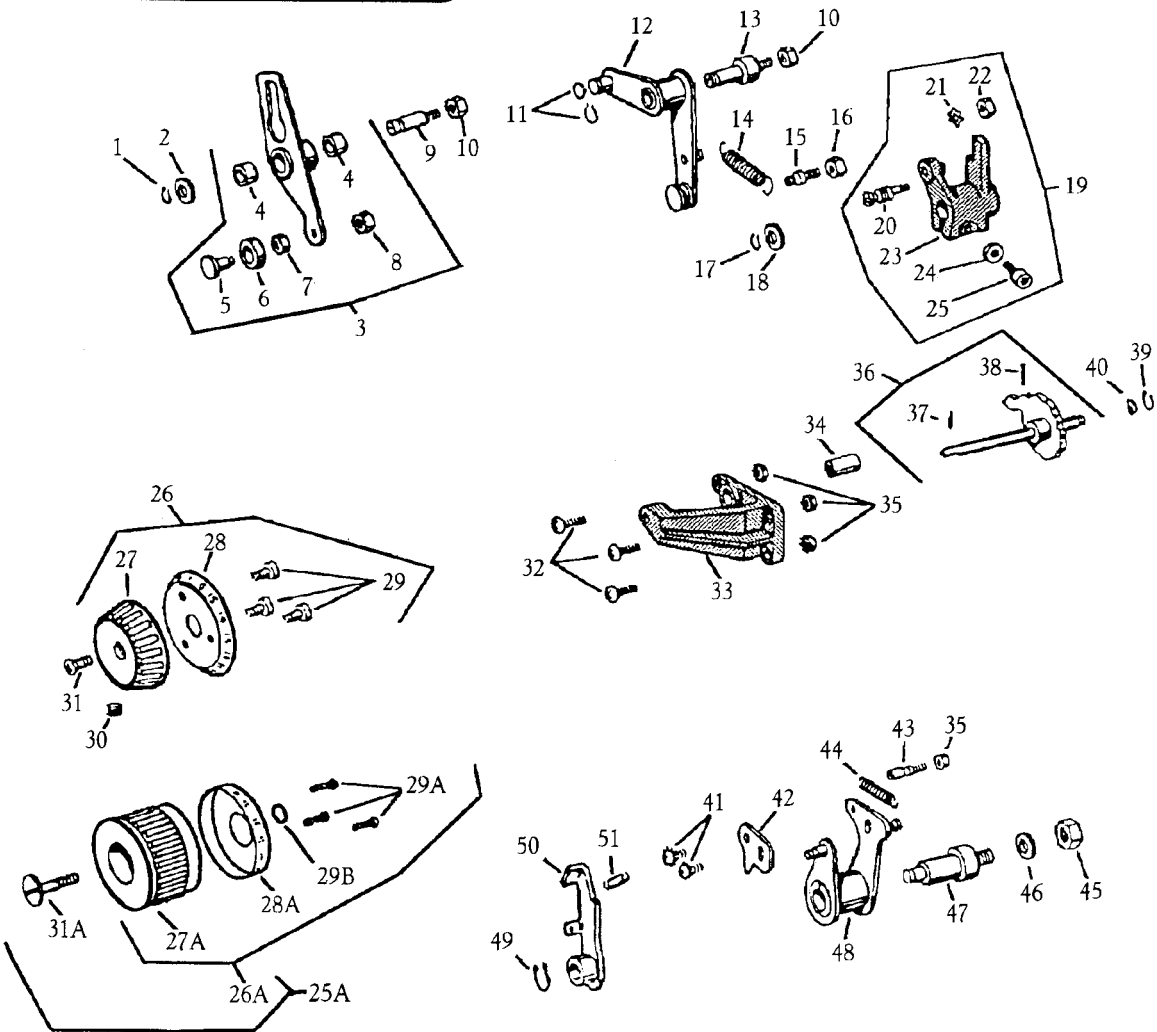
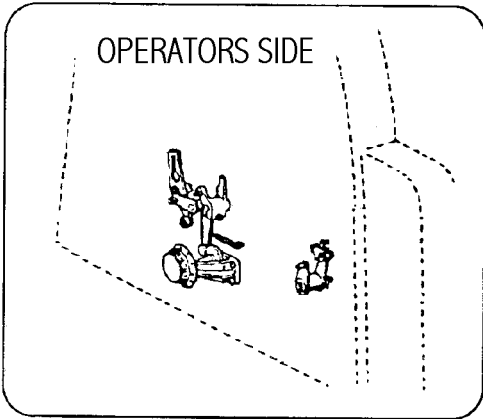

**PAGE #35**  
**BUCKLE ADJUSTING MECHANISM & COUNTER OPERATING LEVER**

KEY #	PART#	DESCRIPTION
1	P-704	<u>SNAP RING</u>
2	P-611	<u>WASHER</u>
3	P-36709	<u>FORWARDING LEVER ASSEMBLY</u> - RIDES ON CAM ASSEMBLY ITEM #13 PAGE 44 AND CONNECTS TO LINK ITEM #16 PAGE 38.
4	P-1203	<u>BUSHING</u>
5	P-1600	<u>RIVET</u> - INCLUDES NUT P-469.
6	P-1455	<u>CAM</u>
7	P-1379	<u>BUSHING</u>
8	P-469	<u>NUT</u>
9	P-7003	<u>STUD</u>
10	P-487	<u>NUT</u>
11	P-703	<u>SNAP RING</u>
12	P-36690	<u>HUB ASSEMBLY</u> - CONNECTS TO LINK ITEM #15 PAGE 38.
13	P-9005	<u>SHOULDER STUD</u>
14	P-36213	<u>SPRING</u>
15	P-6007	<u>SPRING ANCHOR</u>
16	P-471	<u>NUT</u>
17	P-699	<u>RETAINING RING</u>
18	P-596	<u>WASHER</u>
19	P-36698	<u>COUNTER OPERATING LEVER ASSEMBLY</u> - MOUNTS ONTO SHAFT ITEM #20 PAGE 41 AND OPERATES WITH LEVER ITEM #49 PAGE 47 & LINK ITEM #15 PAGE43.
20	P-6021	<u>ECCENTRIC SPRING ANCHOR</u>
21	P-632	<u>LOCKWASHER</u>
22	P-464	<u>NUT</u>
23	P-36704	<u>COUNTER OPERATING LEVER</u>
24	P-583	<u>WASHER</u>
25	P-55	<u>SCREW</u>
25A	P-98700	<u>BUCKLE ADJUSTING KNOB ASSEMBLY COMPLETE</u> - 9800.
26	P-36702	<u>BUCKLE ADJUSTING KNOB ASSEMBLY</u>
26A	P-98702	<u>BUCKLE ADJUSTING KNOB ASSEMBLY</u> - CONSISTS OF ITEMS #27A, #28A & #29A.
27	NO #	<u>BUCKLE ADJUSTING KNOB</u> - NOT SOLD SEPARATELY FOR 350, 360 & 375. SEE P-36702.
27A	P-98183	<u>BUCKLE ADJUSTING KNOB</u> - 9800.
28	P-36708	<u>NUMBER DIAL</u> - 350, 360 & 375.
28A	P-98708	<u>NUMBER DIAL</u> - 9800.
29	P-969	<u>TAPPING SCREW</u>
29A	P-1041	<u>DRIVE SCREW</u>
29B	P-1495	<u>O-RING</u>
30	P-11	<u>SET SCREW</u>
31	P-300	<u>SCREW</u> - NOT USED ON 9800 HANDLES.
31A	P-1493	<u>SCREW</u> - 9800 HANDLES ONLY.
32	P-264	<u>SCREW</u>
33	P-36710	<u>CAM HOUSING ASSEMBLY</u> - PLASTIC.
34	P-817	<u>BUSHING</u> - NOT NEEDED WITH THE PLASTIC HOUSING ASSEMBLY. (USE ONLY ON OLD STYLE CASTINGS).
35	P-471	<u>NUT</u>
36	P-36694	<u>CAM SHAFT ASSEMBLY</u>
37	P-379	<u>ROLL PIN</u>
38	P-428	<u>TAPER PIN</u>
39	P-700	<u>RETAINING RING</u>
40	P-1815	<u>SPRING WASHER</u>
41	P-254	<u>SCREW</u>
42	P-36714	<u>PLATE</u>
43	P-6023	<u>SPRING ANCHOR</u>
44	P-36716	<u>TENSION SPRING</u> - ITEMS #43 & #48 THIS PAGE.
45	P-506	<u>NUT</u>
46	P-634	<u>WASHER</u>
47	P-9008	<u>STUD</u> - TIP OF STUD IS USED TO LATCH ITEM #45 PAGE 39.
48	P-36722	<u>DOUBLE LEVER ASSEMBLY</u> - CONNECTS TO LINK ITEM #11 PAGE 39.
49	P-703	<u>SNAP RING</u>
50	P-36720	<u>LEVER LATCH</u> - LATCHES ON ITEM #34 PAGE 39.
51	P-36266	<u>TENSION SPRING</u> - ATTACHES TO ITEMS #48 & #50 THIS PAGE.

**DRAWING #36**  
**GAP CONTROL & GAP CONTROL INDICATORS**  
**(FOR MASTER & IMPRESSION CYLINDERS)**

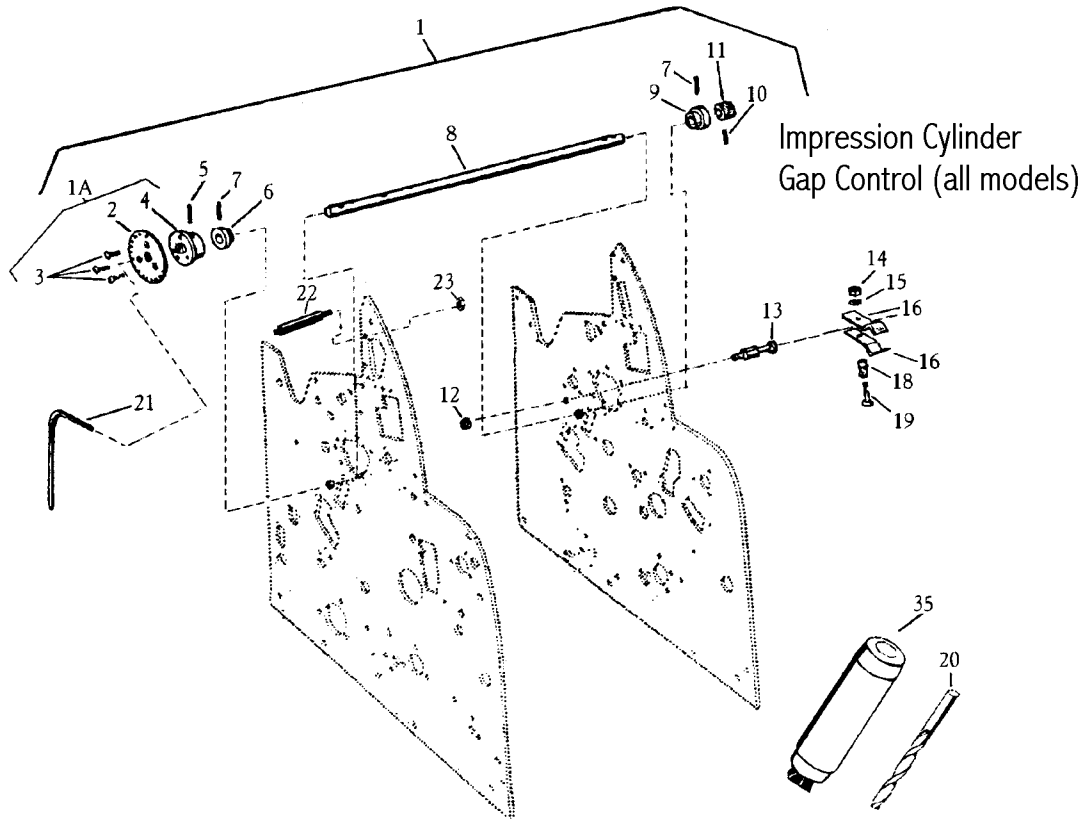

**Master Cylinder Gap Control**  
**(9800 models)**

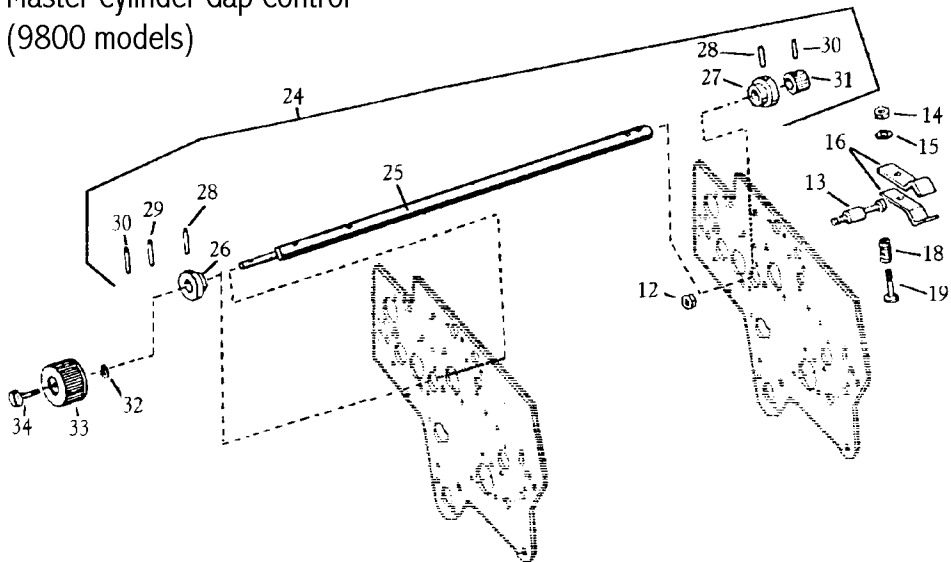

## GAP CONTROL &amp; GAP CONTROL INDICATOR (FOR MASTER &amp; IMPRESSION CYLINDERS)

KEY #	PART#	DESCRIPTION
<b>GAP CONTROL FOR IMPRESSION CYLINDER ON 350, 360, 375 &amp; 9800</b>		
1	P-36689	<u>GAP CONTROL SHAFT ASSEMBLY</u> - 350, 360.
	P-37689	<u>GAP CONTROL SHAFT ASSEMBLY</u> - 375
	P-98689	<u>GAP CONTROL SHAFT ASSEMBLY</u> - 9800 STD., 9800, 1-1.
1A	P-36688	<u>DIAL ASSEMBLY</u> - 350, 360 & 375.
	P-98688	<u>DIAL ASSEMBLY</u> - 9800 ONLY.
2	P-36687	<u>GAP CONTROL DIAL</u> - 350, 360, 375 & 9800.
3	P-114	<u>SCREW</u> - USE 3.
4	P-36691	<u>GAP CONTROL HUB</u> - 350, 360 & 375.
	P-98691	<u>GAP CONTROL HUB</u> - 9800 ONLY.
5	P-403	<u>ROLL PIN</u>
6	P-36693	<u>CAM</u> - OPERATORS SIDE. RIDES ON TOP OF PIN ITEM #1 PAGE 41.
7	P-386	<u>ROLL PIN</u>
8	P-36695	<u>SHAFT</u> - 350, 360.
	P-37695	<u>SHAFT</u> - 375.
	P-98695	<u>SHAFT</u> - 9800 STD., 9800, 1-1.
9	P-36697	<u>CAM</u> - (NON-OPERATORS SIDE) RIDES ON TOP OF PIN ITEM #1, PAGE 41.
10	P-380	<u>ROLL PIN</u>
11	P-36699	<u>DRAG LOCK</u> - (PLASTIC) PILOT HOLE ONLY. MUST HAVE PROPER TOOLS TO INSTALL. DRILL BIT P-1589 & REAMER TOOL P-1546.
12	P-487	<u>LOCKNUT</u>
13	P-9006	<u>PIVOT ANCHOR</u>
14	P-469	<u>NUT</u> - OPTIONAL.
	P-521	<u>NYLOCK NUT</u> - OPTIONAL.
15	P-569	<u>WASHER</u>
16	P-36703	<u>CLAMP</u>
18	P-36707	<u>SPRING</u>
19	P-8019	<u>SCREW</u>
20	P-1589	<u>DRILL BIT</u>
21	P-5912	<u>ALLEN WRENCH</u> - FOR GAP CONTROL ITEM #1 THIS PAGE.
22	P-6027	<u>SPRING ANCHOR</u> - CONNECTS TO ITEM #24 PAGE 37.
23	P-471	<u>NUT</u>
<b>GAP CONTROL FOR THE MASTER CYLINDER ON 9800 ONLY</b>		
24	P-98693	<u>GAP CONTROL SHAFT ASSEMBLY</u> - MASTER CYLINDER.
25	P-98697	<u>SHAFT</u>
26	P-36693	<u>CAM</u> - OPERATORS SIDE.
27	P-36697	<u>CAM</u> - NON-OPERATORS SIDE.
28	P-386	<u>ROLL PIN</u>
29	P-832	<u>ROLL PIN</u>
30	P-380	<u>ROLL PIN</u>
31	P-36699	<u>DRAG LOCK</u> - (PLASTIC) PILOT HOLE ONLY. MUST HAVE PROPER TOOLS TO INSTALL. DRILL BIT P-1589 & REAMER TOOL P-1546.
32	P-1495	<u>SPACER</u>
33	P-98031	<u>KNOB</u>
34	P-8045	<u>SCREW</u>
35	P-1546	<u>REAMER TOOL</u>

**DRAWING #37**  
**SINGLE LEVER CONTROL**

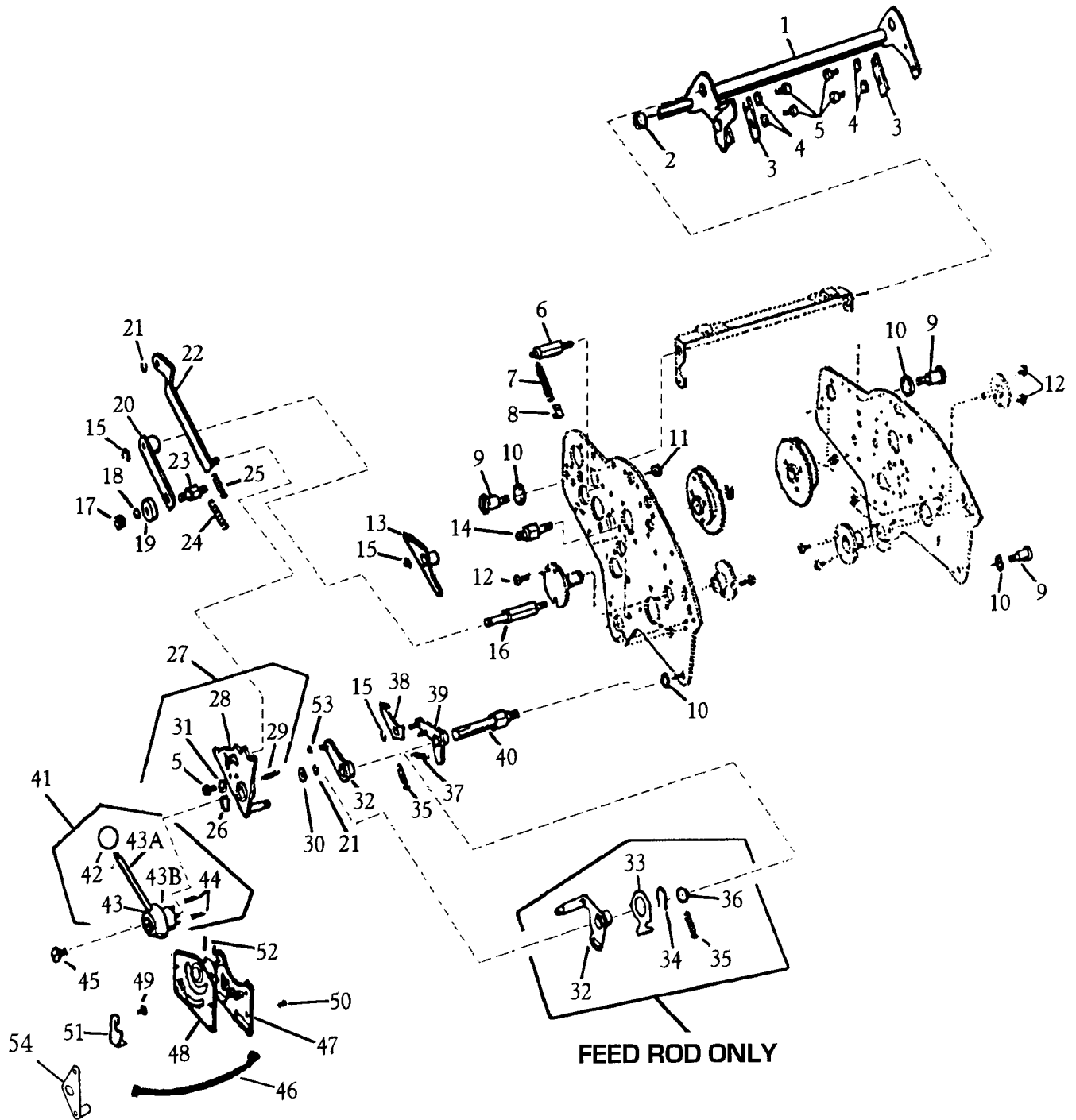



**PAGE #37**  
**SINGLE LEVER CONTROL**

KEY #	PART#	DESCRIPTION
1	P-36846	<u>LEVER &amp; SHAFT ASSEMBLY</u> - GOES THROUGH FRAME AND IS OPERATED BY ITEM #13, THIS PAGE.
	P-37846	<u>LEVER &amp; SHAFT ASSEMBLY</u> - GOES THROUGH FRAME AND IS OPERATED BY ITEM #13, THIS PAGE.
	P-98846	<u>LEVER &amp; SHAFT ASSEMBLY</u> - GOES THROUGH FRAME AND IS OPERATED BY ITEM #13, THIS PAGE.
2	P-1484	<u>SPACER</u>
3	P-36842	<u>ADJUSTMENT SLIDE</u> - SEE ITEM #18A & #19A, PAGE 18 FOR STOP.
4	P-566	<u>WASHER</u>
5	P-895	<u>SCREW</u>
6	P-6030	<u>SPRING ANCHOR</u>
7	P-36832	<u>TENSION SPRING</u>
8	P-36560	<u>SPRING HOOK</u> - SEE ITEM 5, PAGE 45.
9	P-8009	<u>SHOULDER SCREW</u> - 350 S.N.196799,360 S.N.197056 AND BELOW. SEE PAGE 45.
	P-8012	<u>SHOULDER SCREW</u> - 350 S.N.196800,360 S.N.197057 AND ABOVE.INCLUDES PRO MODELS. SEE PAGE 45.
10	P-647	<u>LOCKWASHER</u>
11	P-471	<u>NUT</u>
12	P-271	<u>SCREW</u>
13	P-36836	<u>LEVER</u> - WATER LOCK OUT. SEE ITEM #1, THIS PAGE.
14	P-9031	<u>STUD</u>
15	P-668	<u>SNAP RING</u>
16	P-36806	<u>PIVOT STUD</u> - SEE ITEM #20, THIS PAGE. MOUNTS ON ITEM #7, PAGE 45.
17	P-469	<u>NUT</u>
18	P-625	<u>LOCKWASHER</u>
19	P-765	<u>CAM ROLLER</u> - RIDES ON CAM #28.
20	P-36808	<u>DETENT LEVER</u> - MOUNTS TO STUD #16, THIS PAGE.
21	P-669	<u>SNAP RING</u>
22	P-36820	<u>CONTROL LINK</u> - CONNECTS TO LEVER #46, PAGE 23.
23	P-6028	<u>SPRING ANCHOR</u>
24	P-36810	<u>TENSION SPRING</u> - CONNECTS TO ITEM #23, THIS PAGE & ITEM #22, PAGE 36.
25	P-36814	<u>TENSION SPRING</u> - LIGHT TENSION. CONNECTS TO ITEM #22 AND #28, THIS PAGE.
	P-36816	<u>TENSION SPRING</u> - HEAVY TENSION. CONNECTS TO ITEM #22 AND #28, THIS PAGE.
26	P-705	<u>RETAINING RING</u>
27	P-36823	<u>SEQUENCE CAM ASSEMBLY</u>
28	P-36824	<u>SEQUENCE CAM</u>
29	P-6029	<u>SPRING ANCHOR</u> - SCREWS INTO ITEM #28, THIS PAGE AND ATTACHES TO ITEM #25, THIS PAGE.
30	P-598	<u>WASHER</u>
31	P-1483	<u>CAM</u> - ECCENTRIC.
32	P-36828	<u>FEED LEVER</u> - SEE FEED CABLE. ITEM #11, PAGE 38.
	P-36854	<u>FEED LEVER</u> - SEE FEED ROD. SEE ITEM #33, THIS PAGE.
33	P-36852	<u>LEVER</u> - FEED ROD. SLIDES OVER ITEM #32, THIS PAGE.
34	P-689	<u>RETAINING RING</u>
35	P-36619	<u>SPRING</u> - CONNECTS TO ITEM #33, THIS PAGE.
36	P-1831	<u>WASHER</u>
37	P-36818	<u>TENSION SPRING</u> - CONNECTS TO ITEM #38 & #39, THIS PAGE.
38	P-36830	<u>FEED LEVER</u> - (OVER TRAVEL) CONNECTS TO CABLE #11, PAGE 38.
	P-98830	<u>FEED LEVER</u> - (OVER TRAVEL) CONNECTS TO CABLE #11, PAGE 38.
39	P-36834	<u>IMAGE CONTROL LEVER</u>
	P-98834	<u>IMAGE CONTROL LEVER</u>
40	OBSOLETE	<u>CONTROL LEVER SHAFT</u> - 350 S.N. 196799, 360 S.N. 197056 AND BELOW. SEE NOTE!
	P-36804	<u>CONTROL LEVER SHAFT</u> - 350 S.N. 196800, 360 S.N. 197057 AND ABOVE, INCLUDES PRO MODELS
41	P-36856	<u>OPERATION CONTROL LEVER</u> - FITS INTO ITEM #28, THIS PAGE. SEE ITEM #56, PAGE 47.
	P-98856	<u>OPERATION CONTROL LEVER</u> - FITS INTO ITEM #28, THIS PAGE. SEE ITEM #56, PAGE 47.
42	P-36858	<u>KNOB</u> - ALL MODELS.
43	P-36860	<u>LEVER</u>
	P-98860	<u>LEVER</u>
43A	P-36849	<u>HANDLE SHAFT</u> - ALL MODELS.
43B	P-36850	<u>BASE HUB</u> - 350, 360 & 375.
	P-98850	<u>BASE HUB</u> - 9800 ONLY.
44	P-354	<u>SPIRAL PIN</u> - ALL MODELS.
45	P-1024	<u>SCREW</u>
	P-8049	<u>SHOULDER SCREW</u> - 9800.
46	P-4027	<u>CABLE ASSEMBLY</u> - 9800.
47	P-4028	<u>P.C.BOARD</u> - 9800 OLD STYLE.
	P-9751	<u>P.C. BOARD</u> - 9800 NEW STYLE - HALL EFFECT.
48	P-98820	<u>SENSOR PLATE</u> - 9800 OLD STYLE.
	P-9818	<u>SENSOR PLATE</u> - 9800 NEW STYLE - HALL EFFECT.
49	P-215	<u>SCREW</u>
50	P-235	<u>SCREW</u>
51	P-98654	<u>SENSOR BLADE</u> - 9800 OLD STYLE.
52	P-8	<u>SET SCREW</u>
53	P-666	<u>SNAP RING</u>
54	P-98828	<u>MAGNET AND ARM ASSEMBLY</u> - 9800 NEW STYLE. HALL EFFECT.
		<b>NOTE:</b> MUST BUY NEW SHAFT P-36804, TIE BAR P-36635, & SCREW P-8012. DRILL OUT SIDE FRAME TO MATCH NEW SHAFT P-36804.

**DRAWING #38**  
**FEED CONTROL AND RELATED PARTS**

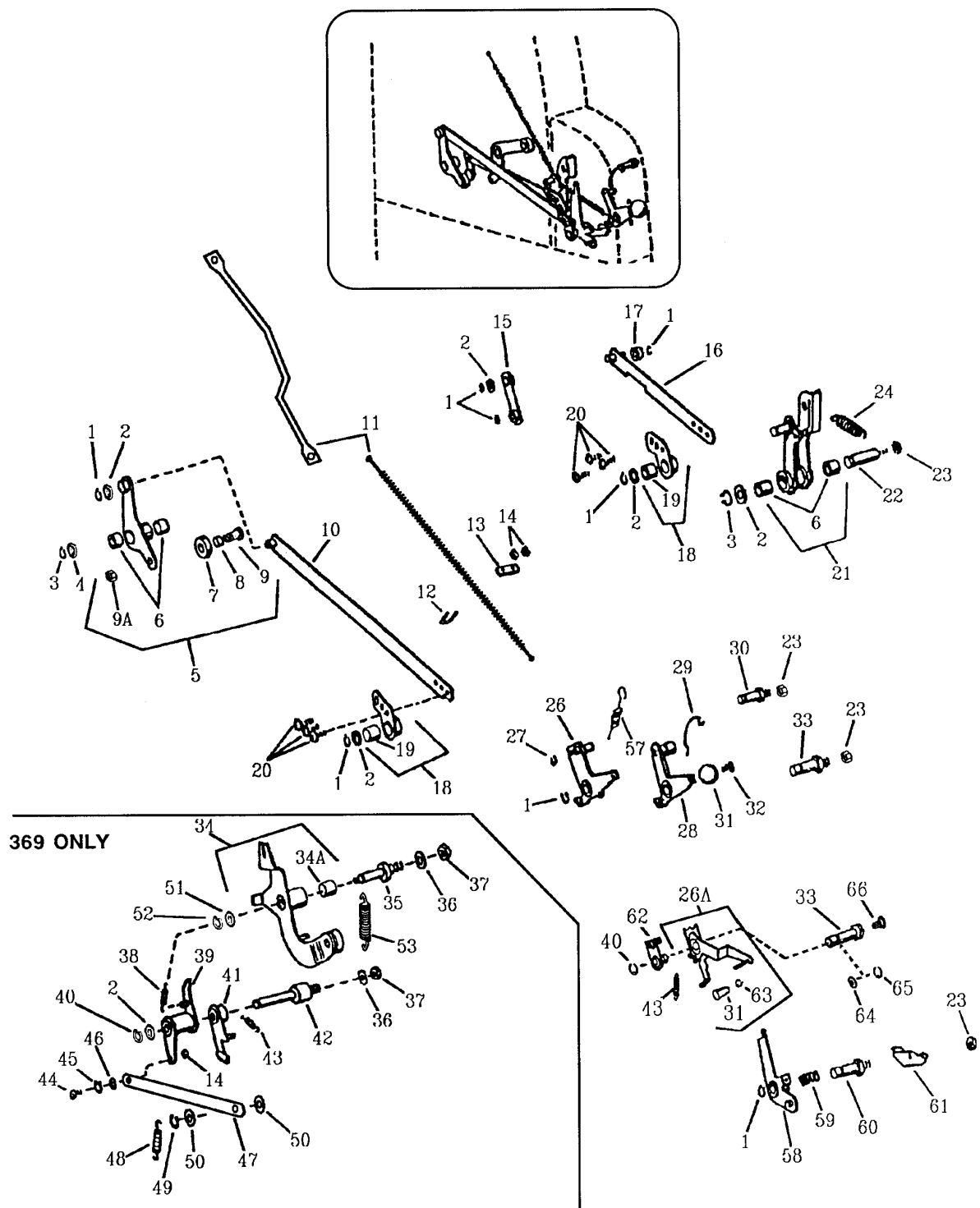

**PAGE #38**  
**FEED CONTROL & RELATED PARTS**

KEY #	PART#	DESCRIPTION
1	P-703	<u>RETAINING RING</u>
2	P-603	<u>WASHER</u>
3	P-704	<u>RETAINING RING</u>
4	P-611	<u>WASHER</u>
5	P-36885	<u>CAM LEVER ASSEMBLY</u> - RIDES ON CAM. ITEM #19 PAGE 44.
6	P-1203	<u>BUSHING</u>
7	P-1455	<u>ROLLER</u>
8	P-1379	<u>BUSHING</u>
9	P-1392	<u>SCREW &amp; NUT</u>
9A	P-474	<u>NUT</u>
10	P-36889	<u>MASTER LINK</u>
11	P-36891	<u>CABLE</u> - (NEEDED WITH OPERATION CONTROL LEVER) CONNECTS TO LEVER ITEM #32 PAGE 37 & ITEM #26 THIS PAGE.
	P-36863	<u>FEED ROD</u> - CONNECTS TO ITEM #32 PAGE 37 & ITEM #62 THIS PAGE
12	P-36893	<u>U-CLAMP</u> - (NEEDED WITH OPERATION CONTROL LEVER)
13	P-36895	<u>CABLE TIE CLAMP</u> - (NEEDED WITH OPERATION CONTROL LEVER)
14	P-471	<u>NUT</u>
15	P-36897	<u>LINK</u> - CONNECTS TO HUB ASSEMBLY ITEM #12 PAGE 35.
16	P-36899	<u>LINK ASSEMBLY</u> - CONNECTS TO LEVER ITEM #3 PAGE 35.
17	P-1476	<u>ROLLER</u>
18	P-36901	<u>ADJUSTING HINGE</u> - ATTACHES TO LEVER ITEM #24 PAGE 9.
19	P-822	<u>BUSHING</u>
20	P-278	<u>SCREW</u>
21	P-36903	<u>DOUBLE LEVER ASSEMBLY</u> - INCLUDES P-1203, BUSHING. CONTACTS CAM ITEM #6 PAGE 9.
22	P-7003	<u>STUD</u>
23	P-487	<u>NUT</u>
24	P-36032	<u>SPRING</u> - ATTACHES TO STUD ITEM #2, PAGE 7.
26	P-36905	<u>PAPER FEED LEVER</u> - (USED WITH OPERATION CONTROL LEVER).
26A	P-98905	<u>PAPER FEED LEVER</u> - (USED WITH OPERATION CONTROL LEVER) - 9800 - INCLUDES ITEM #31 & ITEM #63.
27	P-666	<u>RETAINING RING</u>
28	P-36907	<u>PAPER FEED LEVER</u> - (MANUAL)
29	P-36909	<u>LOOP SPRING</u> - 350, 360 & 375.
	P-98909	<u>LOOP SPRING</u> - 9800.
30	P-6033	<u>SPRING ANCHOR</u> - 350, 360 & 375.
	P-6047	<u>SPRING ANCHOR</u> - 9800 ONLY.
31	P-36270	<u>KNOB</u> - ROUND
	P-36062	<u>KNOB</u> - TAPERED
32	P-993	<u>SCREW</u>
33	P-9034	<u>STUD</u> - GOES THROUGH ITEM #28 THIS PAGE & ITEM #11 ATTACHES TO IT - EXTERNAL THREADS FOR ALL BUT 9800
	P-8050	<u>STUD</u> - GOES THROUGH ITEM #26 THIS PAGE & ITEM #11 ATTACHES TO IT - INTERNAL THREADS FOR 9800
34	P-36915	<u>CAM LEVER</u> - 369 PRESS.
34A	P-814	<u>BUSHING</u>
35	P-6034	<u>SPRING ANCHOR</u>
36	P-1595	<u>WASHER</u>
37	P-497	<u>NUT</u>
38	P-36921	<u>SPRING</u>
39	P-36923	<u>LATCH</u>
40	P-670	<u>C-RING</u>
41	P-36925	<u>CYCLE COUNT LEVER</u>
42	P-9036	<u>STUD</u>
43	P-36929	<u>SPRING</u>
44	P-36931	<u>SCREW</u>
45	P-669	<u>C-RING</u>
46	P-595	<u>WASHER</u>
47	P-36933	<u>LINK</u>
48	P-36266	<u>SPRING</u>
49	P-699	<u>C-RING</u>
50	P-596	<u>WASHER</u>
51	P-598	<u>WASHER</u>
52	P-669	<u>C-RING</u>
53	P-36918	<u>SPRING</u>
57	P-36943	<u>LEVER LINK SPRING</u> - CONNECTS TO ITEM #33 & ITEM #58 THIS PAGE.
58	P-36945	<u>LATCH</u> - (350, 360, 360 PRO, & 369 PRESSES)
	P-36947	<u>LATCH</u> - (369 PRESSES ONLY)
	P-98945	<u>LATCH</u> - (9800 PRESSES ONLY) - USED WITH P-36921 SPRING.
59	P-36949	<u>SPRING</u>
	P-36921	<u>SPRING</u> - USED WITH P-98945 LATCH ITEM #58.
60	P-9035	<u>STUD</u>
61	P-36935	<u>PAPER WEIGHT REST</u>
62	P-98907	<u>LEVER ASSEMBLY</u> - 9800
63	P-36410	<u>SPRING</u>
64	P-621	<u>WASHER</u>
65	P-673	<u>C-RING</u>
66	P-91	<u>SCREW</u>

**DRAWING #39**  
**POWER LINK, FEED MECHANISM & TABLE RELEASE LEVER**

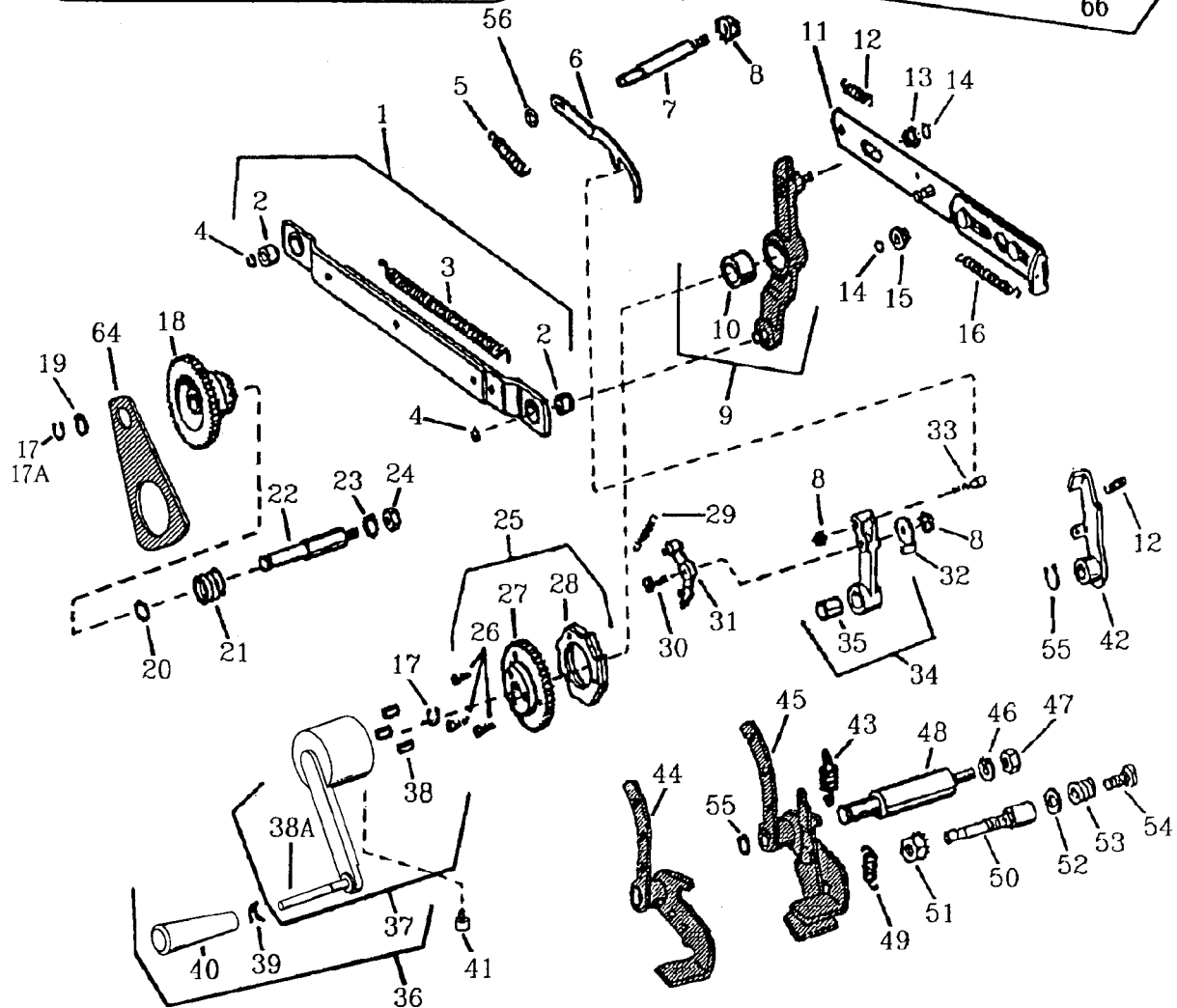
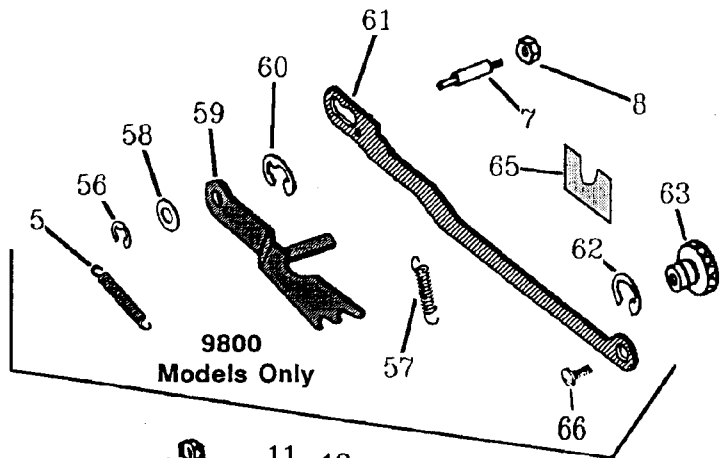
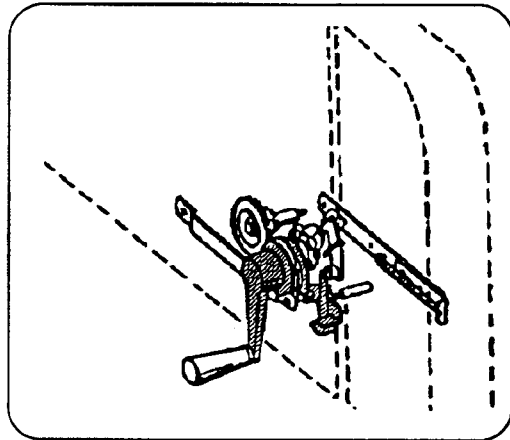

**PAGE #39**  
**POWER LINK, FEED MECHANISM & TABLE RELEASE LEVER**

KEY #	PART#	DESCRIPTION
1	P-36919	<u>POWER LINK ASSEMBLY</u> - CONNECTS TO LEVER ITEM #20, PAGE 44 & LEVER ITEM #9 THIS PAGE.
2	P-812	<u>BUSHING</u>
3	P-36985	<u>SPRING</u> - ATTACHES TO ITEM #1 THIS PAGE. 1 FOR EACH END.
4	P-669	<u>C-RING</u>
5	P-36660	<u>SPRING</u> - ATTACHES TO ITEM #32 THIS PAGE.
6	P-36944	<u>STOP GUIDE</u> - LATCHES ONTO ITEM #33 THIS PAGE.
	P-98944	<u>STOP GUIDE</u> - LATCHES ONTO ITEM #33 THIS PAGE.
7	P-6037	<u>SPRING ANCHOR</u> - ATTACHES TO SIDE FRAME.
8	P-487	<u>KEPS NUT</u>
9	P-36927	<u>ARM ASSEMBLY</u> - CENTER HOLE TO SHAFT ITEM #4 PAGE 8.
10	P-1269	<u>BUSHING</u>
11	P-36941	<u>LINK</u> - FOR BLOWER TUBE CONTROL. ATTACHES TO LEVER ITEM #2 PAGE 6 & ITEM #48 PAGE 35.
12	P-36266	<u>SPRING</u> - ATTACHES TO ITEMS #48 & #50 PAGE 35.
13	P-1369	<u>BUSHING</u>
14	P-698	<u>RETAINING RING</u>
15	P-1370	<u>BUSHING</u>
16	P-36327	<u>SPRING</u>
17	P-705	<u>RETAINING RING</u> - FOR 360 PRO. FOR P-9041.
17A	P-729	<u>RETAINING RING</u> - FOR 350, 360 & 369. FOR P-9040.
18	P-36452	<u>MITER &amp; SPUR GEAR</u> - FOR 350, 360, 360 PRO & 369. RUNS WITH ITEM #18 PAGE 8.
19	P-1382	<u>WASHER</u> - FOR 360 PRO.
20	P-1057	<u>SPACER</u>
21	P-36454	<u>SPRING</u>
22	P-9040	<u>STUD</u> - FOR 350, 360 & 369.
	P-9041	<u>STUD</u> - FOR 360 PRO, MUST HAVE P-1382 WASHER.
	P-7016	<u>STUD</u> - FOR 9800 ONLY.
23	P-634	<u>EXTERNAL LOCKWASHER</u>
24	P-506	<u>NUT</u>
25	P-36975	<u>GEAR &amp; RATCHET ASSEMBLY</u> - ATTACHES TO SHAFT ASSEMBLY ITEM #4 PAGE 8.
	P-98975	<u>GEAR &amp; RATCHET ASSEMBLY</u> - ATTACHES TO SHAFT ASSEMBLY ITEM #4 PAGE 8.
26	P-44	<u>ALLEN HEAD CAP SCREW</u>
27	P-36974	<u>GEAR</u>
28	P-36973	<u>RATCHET</u> - 350, 360, 360 PRO, 369& 375.
	P-98973	<u>RATCHET</u> - 9800.
29	P-36718	<u>SPRING</u> - CONNECTS TO ITEM #31 & #33 THIS PAGE.
30	P-8027	<u>SHOULDER SCREW</u>
31	P-36937	<u>PAWL</u> - 350, 360, 360 PRO, 369& 375.
	P-98937	<u>PAWL</u> - 9800.
32	P-36939	<u>SPRING ANCHOR CLIP</u>
33	P-6038	<u>SPRING ANCHOR STUD</u>
34	P-36979	<u>LATCH ARM ASSEMBLY</u> - LATCHES ITEM #42 THIS PAGE. ATTACHES TO SHAFT ITEM #4 PAGE 8.
35	P-1244	<u>BUSHING</u>
36	P-36955	<u>HAND CRANK ASSEMBLY</u> - 350, 360 & 375. SEE ITEM #4 PAGE 8. SEE ITEM #58 PAGE 47.
	P-98955	<u>HAND CRANK ASSEMBLY</u> - 9800. SEE ITEM #4 PAGE 8. SEE ITEM #27 PAGE 47A.
	P-38955	<u>HAND CRANK ASSEMBLY</u> - 385. SEE ITEM #4 PAGE 8. SEE ITEM #58 PAGE 47.
37	P-36957	<u>CRANK ASSEMBLY</u> - 350, 360 & 375. ATTACHES TO SHAFT ITEM #4 PAGE 8.
	P-98957	<u>CRANK ASSEMBLY</u> - 9800. ATTACHES TO SHAFT ITEM #4 PAGE 8.
	P-38957	<u>CRANK ASSEMBLY</u> - 385. ATTACHES TO SHAFT ITEM #4 PAGE 8.
38	P-410	<u>ROLL PIN</u> - 350, 360, 375 & 385. 3 PER HAND CRANK ASSEMBLY.
	P-412	<u>ROLL PIN</u> - 9800 ONLY. 3 PER HAND CRANK ASSEMBLY.
38A	P-36962	<u>HAND HOLDER SHAFT</u>
39	P-36959	<u>LOCK SPRING</u>
40	P-36961	<u>ALUMINUM HANDLE</u> - 350, 360, 375 & 385.
	P-98961	<u>STEEL HANDLE</u> - 9800.
41	P-36946	<u>SCREW</u>
42	P-36720	<u>LEVER LATCH</u> - SEE ITEM #48 PAGE 35.
43	P-36965	<u>SPRING</u> - ATTACHES TO ITEM #45 THIS PAGE - TOP & BOTTOM.
44	P-36967	<u>RELEASE LEVER</u> - (MANUAL) OLD STYLE.
45	P-36969	<u>RELEASE LEVER</u> - (SELF LOCKING) LATCHES TO ITEM #47 PAGE 35.
	P-37969	<u>RELEASE LEVER</u> - (SELF LOCKING) LATCHES TO ITEM #47 PAGE 35.
46	P-629	<u>SPLIT LOCKWASHER</u>
47	P-506	<u>NUT</u>
48	P-9038	<u>STUD-C-RING ANCHOR</u>
49	P-36787	<u>SPRING</u> - ATTACHES ITEM #47 TO #50 THIS PAGE.
50	P-6035	<u>SPRING ANCHOR STUD</u>
51	P-507	<u>KEPS NUT</u>
52	P-613	<u>WASHER</u>
53	P-36786	<u>SPRING</u>
54	P-36784	<u>SCREW</u>
55	P-703	<u>RETAINING RING</u>
56	P-670	<u>C-RING</u>
57	P-36918	<u>SPRING</u>
58	P-1752	<u>WASHER</u>
59	P-98927	<u>PAWL</u> - FEED TABLE REGULATOR - 9800 ONLY. TAKES THE PLACE OF ITEM #6 THIS PAGE.
60	P-672	<u>C-RING</u>
61	P-98985	<u>LINK</u> - (SECOND DESIGN)
	P-98454	<u>LINK</u> - (FIRST DESIGN)
62	P-1753	<u>CRESENT RING</u>
63	P-98919	<u>KNOB</u> - REGULATES RATE OF FEED TABLE (LOCATED INSIDE FRAME)
64	P-37452	<u>BRACE</u>
65	P-98710	<u>DECAL</u> - "HIGH & LOW" (LOCATED INSIDE FRAME)
66	P-8017	<u>SHOULDER SCREW</u>

**DRAWING #40**  
**IMPRESSION CYLINDER CONTROL, POWER LEVER & FEED SOLENOID**

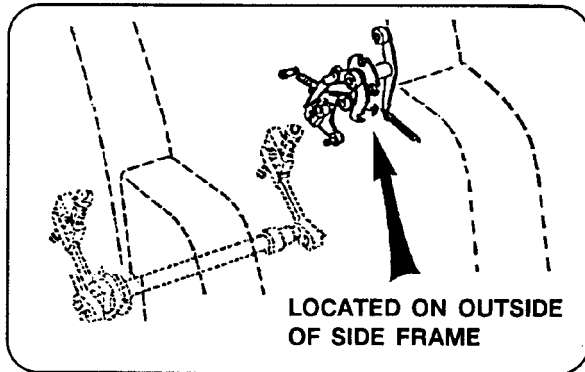

Items #27 & #39 - #46  
 used on 9815 - 9850

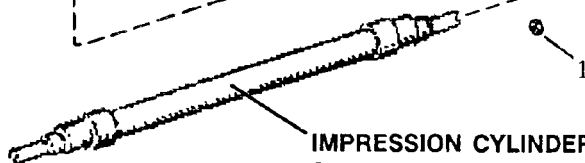
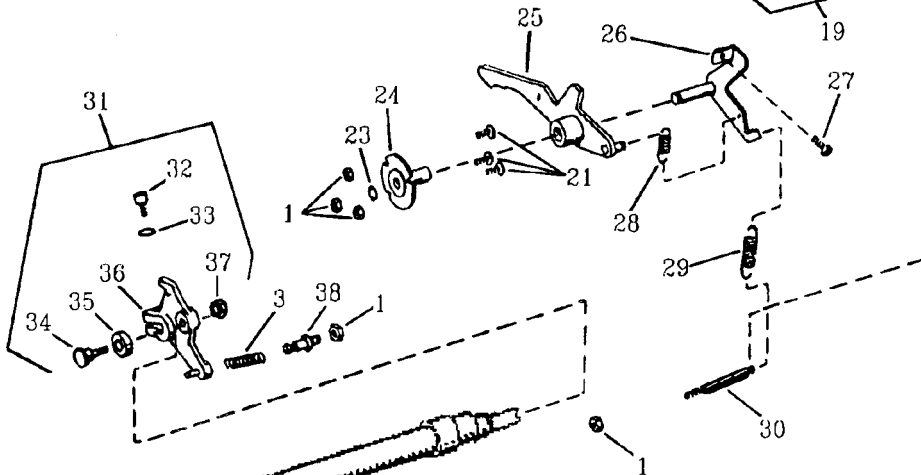
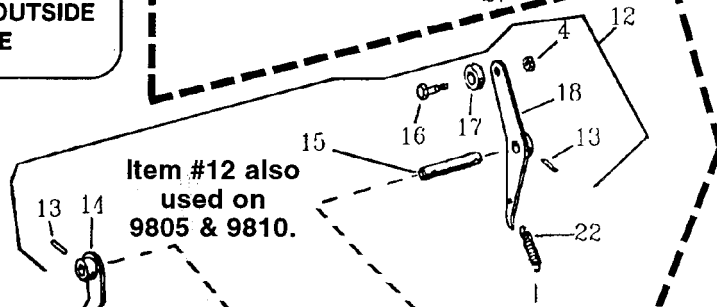
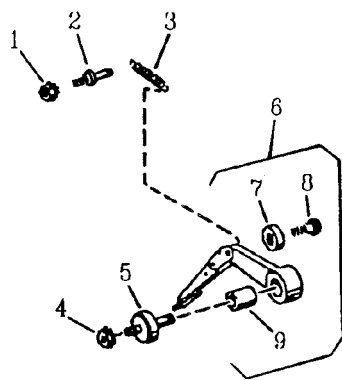
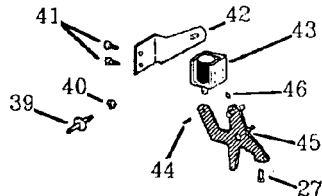

**IMPRESSION CYLINDER SHAFT.**  
 SEE PAGE 12 FOR IMPRESSION CYLINDER,  
 AND PAGE 41 FOR IMPRESSION CYLINDER SUPPORT ARMS.

## IMPRESSION CYLINDER CONTROL, POWER LEVER &amp; FEED SOLENOID

KEY #	PART#	DESCRIPTION
1	P-471	<u>KEPS NUT</u>
2	P-6022	<u>SPRING ANCHOR</u>
3	P-36032	<u>SPRING</u>
4	P-487	<u>NUT</u>
5	P-9007	<u>STUD</u>
6	P-36715	<u>LEVER ASSEMBLY</u>
7	P-1463	<u>CAM ROLLER</u> - FOR CAM SEE ITEM #16, PAGE 14.
8	P-8020	<u>SHOULDER SCREW</u>
9	P-826	<u>BUSHING</u>
10	P-604	<u>WASHER</u>
11	P-670	<u>C-RING</u>
12	P-36839	<u>FEELER LEVER ASSEMBLY</u>
13	P-349	<u>SPRING PIN</u>
14	P-36719	<u>FEELER LEVER</u> - NOT SOLD SEPARATELY, SEE P-36839.
15	P-36721	<u>SHAFT</u> - NOT SOLD SEPARATELY, SEE P-36839.
16	P-8021	<u>SHOULDER SCREW</u> - NOT SOLD SEPARATELY, SEE P-36839.
17	P-1465	<u>CAM ROLLER</u> - FOR CAM SEE PAGE 14, ITEM #16.
18	P-36725	<u>LOCK LEVER</u> - NOT SOLD SEPARATELY, SEE P-36839.
19	P-36727	<u>HOUSING ASSEMBLY</u>
20	P-820	<u>BUSHING</u>
21	P-81	<u>SCREW</u>
22	P-36729	<u>SPRING</u>
23	P-700	<u>RETAINING RING</u>
24	P-36731	<u>HOUSING</u>
25	P-36733	<u>LEVER LATCH</u>
	P-98733	<u>LEVER LATCH</u>
26	P-36735	<u>LEVER LATCH ADJUSTMENT</u>
27	P173	<u>SCREW</u>
28	P-36737	<u>SPRING</u>
29	P-36739	<u>SPRING</u>
	P-98739	<u>SPRING</u>
30	P-6024	<u>SPRING ANCHOR</u>
31	P-36743	<u>POWER LEVER ASSEMBLY</u>
32	P-57	<u>SCREW</u>
33	P-635	<u>WASHER</u>
34	P-8022	<u>ECCENTRIC SHOULDER SCREW</u>
35	P-1462	<u>CAM ROLLER</u>
36	P-36747	<u>POWER LEVER</u>
37	P-489	<u>KEPS NUT</u>
38	P-6010	<u>SPRING ANCHOR</u>
	P-6049	<u>SPRING ANCHOR</u> - 9800
39	P-6048	<u>SPRING ANCHOR</u> - 9800
40	P-472	<u>NUT</u>
41	P-204	<u>SCREW</u>
42	P-98731	<u>BRACKET</u> - 9800
43	P-4029	<u>SOLENOID</u> - 9800 (TAKES THE PLACE OF ITEM #12 ON THIS PAGE.)
44	P-3008	<u>PIN</u> - 9800
45	P-98735	<u>LEVER LATCH ADJUSTMENT</u> - 9800
46	P-508	<u>O-RING</u>

**DRAWING #41**  
**IMPRESSION CYLINDER SUPPORT ARMS & CYLINDER SHAFT**

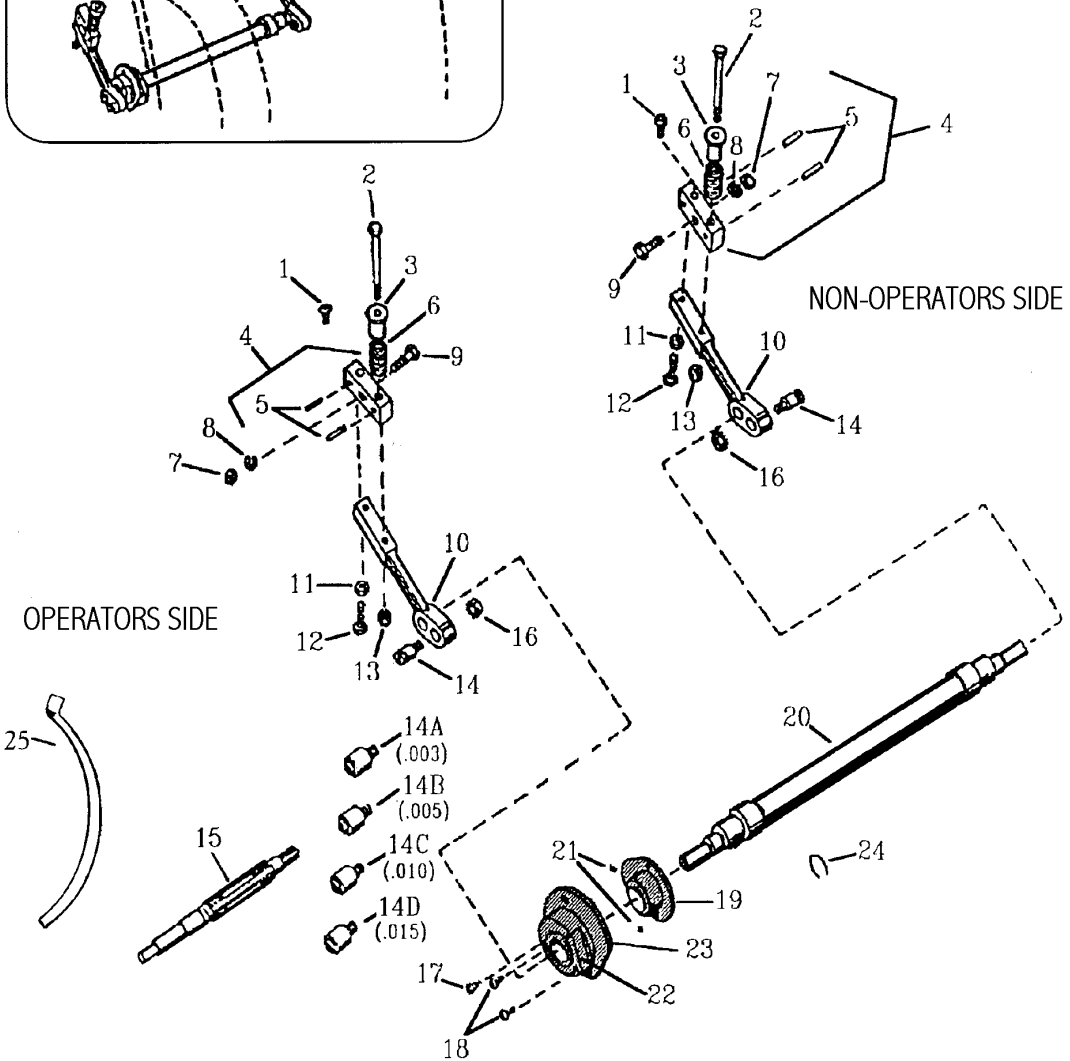
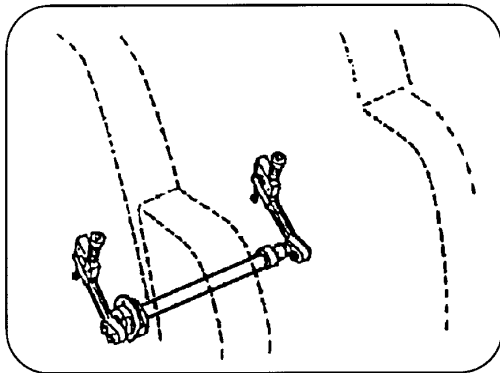

**SEE PAGE #12 FOR IMPRESSION CYLINDER**  
**AND SEE PAGE #40 FOR IMPRESSION CYLINDER LEVERS AND LATCH.**



**PAGE #41**  
**IMPRESSION CYLINDER SUPPORT ARMS & CYLINDER SHAFT**

KEY #	PART#	DESCRIPTION
1	P-36749	<u>PIN</u> - USED ON BLOCKS FOR MACHINES WITH GAP CONTROL. CAM ITEMS #6 & #9, PAGE 36 SIT ON THESE PINS.
2	P-1044	<u>HEX HEAD BOLT</u>
3	P-36717	<u>SPRING GUIDE</u>
	P-98717	<u>SPRING GUIDE</u> - USE WITH P-98759 SPRING.
4	P-36753	<u>BLOCK ASSEMBLY</u> - FOR MACHINES WITHOUT GAP CONTROL, MOUNTS TO SIDE FRAME.
	P-36755	<u>BLOCK ASSEMBLY</u> - FOR MACHINES WITH GAP CONTROL, MOUNTS TO SIDE FRAME.
5	P-403	<u>ROLL PIN</u>
6	P-36757	<u>PRESSURE SPRING</u> - NEEDED FOR MACHINES WITHOUT GAP CONTROL
	P-36759	<u>PRESSURE SPRING</u> - NEEDED FOR MACHINES WITH GAP CONTROL
	P-98759	<u>PRESSURE SPRING</u> - 375 & 9800 - NEEDED FOR MACHINES WITH GAP CONTROL
7	P-506	<u>NUT</u>
8	P-629	<u>SPLIT LOCKWASHER</u>
9	P-958	<u>HEX HEAD SHOULDER BOLT</u>
10	P-36761	<u>SUPPORT ARM</u> - NEEDED FOR MACHINES WITHOUT GAP CONTROL, 5/8" DIA. FOR STUD, ITEM #14
	P-36763	<u>SUPPORT ARM</u> - NEEDED FOR MACHINES WITH GAP CONTROL, 3/4" DIA. FOR STUD, ITEM #14
11	P-492	<u>NUT</u>
12	P-953	<u>SUPPORT BOLT</u>
13	P-524	<u>LOCKNUT</u> - (NYLOCK)
14	P-9009	<u>PIVOT STUD</u> - FOR MACHINES WITHOUT GAP CONTROL
	P-9010	<u>PIVOT STUD</u> - FOR MACHINES WITH GAP CONTROL
14A	P-9011	<u>PIVOT STUD</u> - (THREE THOUSANDTHS .003 OVERSIZE, MUST HAVE PROPER TOOLS ITEM #15 THIS PAGE P-1576, FOR WORN SUPPORT ARMS.
14B	P-9012	<u>PIVOT STUD</u> - (FIVE THOUSANDTHS .005 OVERSIZE, MUST HAVE PROPER TOOLS ITEM #15 THIS PAGE P-1576, FOR WORN SUPPORT ARMS.
14C	P-9013	<u>PIVOT STUD</u> - (TEN THOUSANDTHS .010 OVERSIZE, MUST HAVE PROPER TOOLS ITEM #15 THIS PAGE P-1576, FOR WORN SUPPORT ARMS.
14D	P-9014	<u>PIVOT STUD</u> - (FIFTEEN THOUSANDTHS .015 OVERSIZE, MUST HAVE PROPER TOOLS ITEM #15 THIS PAGE P-1576, FOR WORN SUPPORT ARMS.
15	P-1576	<u>ADJUSTABLE REAMER</u>
16	P-507	<u>KEPS NUT</u>
17	P-8023	<u>SHOULDER SCREW</u>
18	P-262	<u>SCREW</u>
19	P-36783	<u>CAM</u> - FOR OPERATING STRIPPER FINGERS (NOT NEEDED WITH CHAIN DELIVERY), SEE ITEM #50, PAGE 12.
	P-37783	<u>CAM</u> - FOR OPERATING STRIPPER FINGERS (NOT NEEDED WITH CHAIN DELIVERY), SEE ITEM #50, PAGE 12.
20P	P-36781	<u>IMPRESSION CYLINDER SHAFT</u> - SEE ITEM #19, PAGE 35.
	P-37781	<u>IMPRESSION CYLINDER SHAFT</u> - SEE ITEM #19, PAGE 35.
21	P-27	<u>SET SCREW</u>
22	P-36779	<u>CAM</u> - FOR OPERATING GRIPPER SHAFT (CHUTE DELIVERY), SEE ITEM #21, PAGE 12.
	P-36730	<u>CAM ASSEMBLY</u> - FOR OPERATING GRIPPER SHAFT (CHAIN DELIVERY), SEE ITEM #21, PAGE 12.
	P-37779	<u>CAM ASSEMBLY</u> - FOR OPERATING GRIPPER SHAFT (CHUTE DELIVERY), SEE ITEM #21, PAGE 12.
	P-98730	<u>CAM ASSEMBLY</u> - FOR OPERATING GRIPPER SHAFT (CHAIN DELIVERY), SEE ITEM #21, PAGE 12.
23	P-36744	<u>CAM PLATE</u> - CHAIN DELIVERY - SEE ITEM 21 PAGE 12. (BLOCK IS NOT SOLD SEPARATELY).
24	P-1330	<u>CRESCENT RING</u>
25	P-5950	<u>GUAGE</u> - FOR IMPRESSION CYLINDER ARM ADJUSTMENT.
26	P-5948	<u>CYLINDER SHAFT PULLER</u> - FOR IMPRESSION & MASTER CYLINDER SHAFT. SEE PAGE 42.
<p><b>NOTE:</b> IF YOUR CYLINDER SUPPORT ARMS ARE WORN, YOU CAN EASILY REPLACE JUST THE STUD. USING AN ADJUSTABLE REAMER BORE OUT THE HOLE AND INSERT THE NEXT SIZE STUD. IT'S SIMPLE AND SAVES YOU MONEY!</p>		

**DRAWING #42**  
**MASTER CYLINDER SUPPORT ARMS & SHAFT**

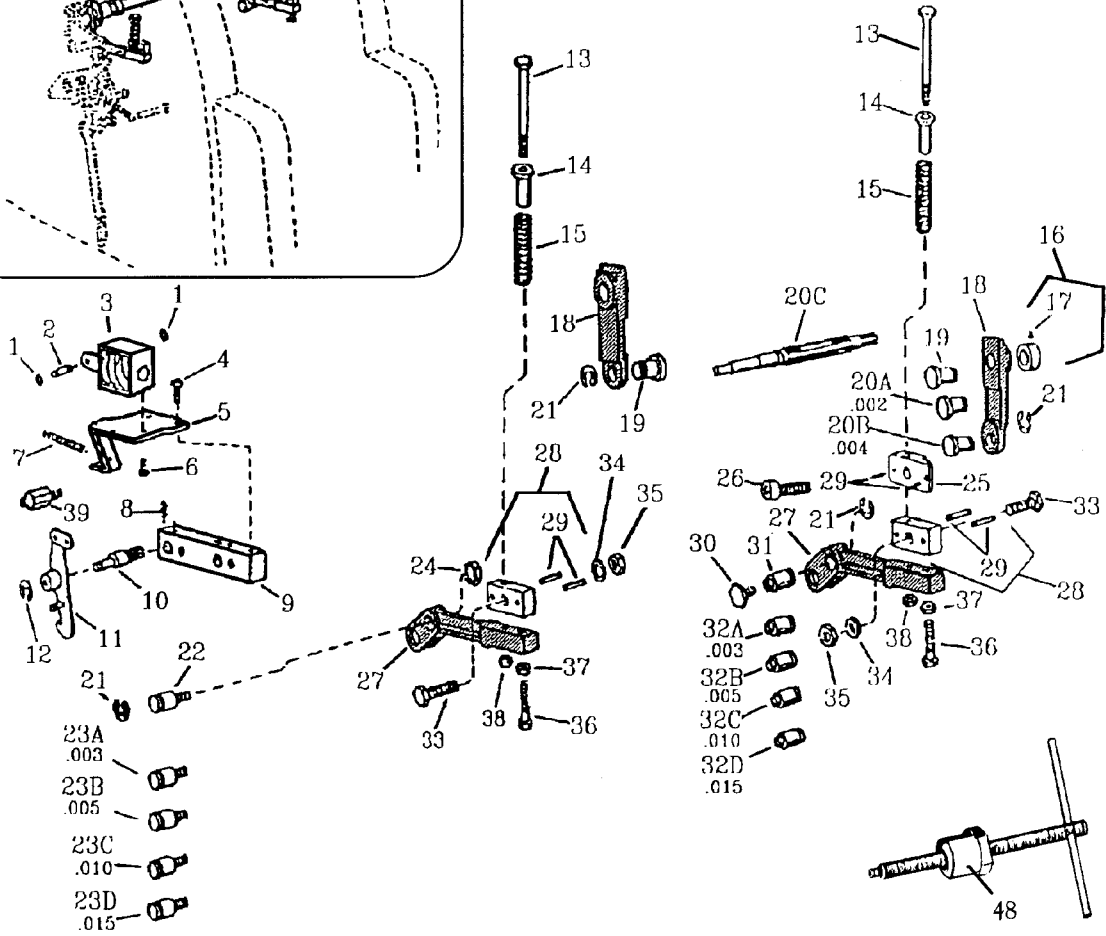
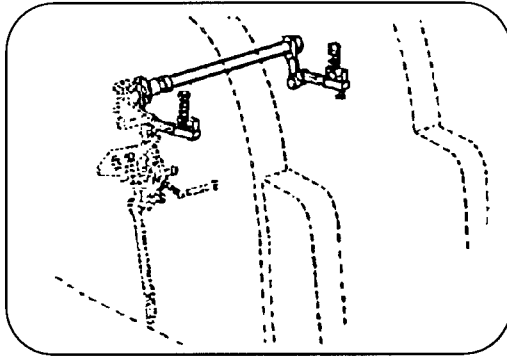

OPERATORS SIDE

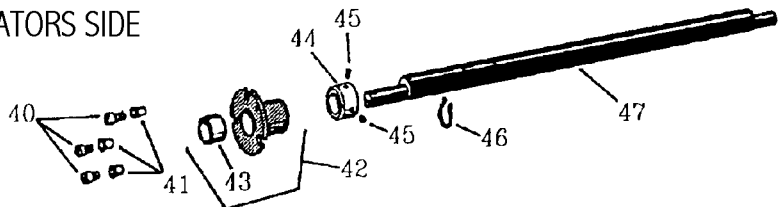

NON-OPERATORS SIDE

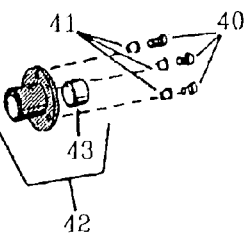

**SEE PAGES 15, 16, 17, & 17A FOR MASTER CYLINDER  
 AND PAGES 42 & 43 FOR MASTER CYLINDER SUPPORT ARMS, POWER LEVER & LATCH.**

**PAGE #42**  
**MASTER CYLINDER SUPPORT ARMS & SHAFT**

KEY #	PART#	DESCRIPTION
1	P-552	<u>RUBBER O-RING</u>
2	P-3075	<u>PIVOT PIN</u> - (369 ARMS ONLY) - CONNECTS TO ITEM #11, THIS PAGE.
3	P-36855	<u>SOLENOID</u> - (115V. 60HZ. 369 ARMS ONLY).
4	P-257	<u>SCREW</u>
5	P-36751	<u>SOLENOID MOUNT</u> - (369 ARMS ONLY).
6	P-235	<u>SCREW</u>
7	P-36791	<u>SPRING</u> - (369 ARMS ONLY) - CONNECTS TO ITEMS #11 & 5, THIS PAGE.
8	P-25	<u>SET SCREW</u>
9	P-36793	<u>RIGHT HAND PRESSURE BLOCK</u> - (369 ARMS ONLY) - MOUNTS TO SIDE FRAME.
10	P-9016	<u>ECCENTRIC STUD</u> - (369 ARMS ONLY).
11	P-36797	<u>LEVER LATCH</u> - (369 ARMS ONLY)
12	P-668	<u>C-RING</u>
13	P-1044	<u>CONNECTING BOLT</u>
14	P-36717	<u>SPRING GUIDE</u>
15	P-36757	<u>SPRING</u>
16	P-743	<u>COLLAR</u>
17	P-8	<u>SET SCREW</u>
18	P-36801	<u>UPPER SUPPORT ARM</u> - CONNECTS TO ITEM #47 THIS PAGE. ONE ON EACH END.
	P-37801	<u>UPPER SUPPORT ARM</u> - CONNECTS TO ITEM #47 THIS PAGE. ONE ON EACH END.
19	P-9018	<u>PIVOT STUD</u>
20A	P-9019	<u>PIVOT STUD</u> - 2 THOUSANDTHS .002 OVERSIZED. <i>SEE NOTE.</i>
20B	P-9020	<u>PIVOT STUD</u> - 4 THOUSANDTHS .004 OVERSIZED. <i>SEE NOTE.</i>
20C	P-1550	<u>ADJUSTABLE REAMER</u> - FOR ARMS WITH 1/2" DIA. HOLES. SIZE RANGE: 15/32" - 17/32".
	P-5951	<u>ADJUSTABLE REAMER</u> - FOR ARMS WITH 9/16" DIA. HOLES. SIZE RANGE: 17/32" - 19/32".
21	P-672	<u>C-RING</u>
22	P-9021	<u>PIVOT STUD</u> - FOR OLD STYLE SUPPORT ARMS WITH 1/2" HOLE.
23A	P-9022	<u>PIVOT STUD</u> - 3 THOUSANDTHS .003 OVERSIZED. <i>SEE NOTE.</i>
23B	P-9023	<u>PIVOT STUD</u> - 5 THOUSANDTHS .005 OVERSIZED. <i>SEE NOTE.</i>
23C	P-9024	<u>PIVOT STUD</u> - 10 THOUSANDTHS .010 OVERSIZED. <i>SEE NOTE.</i>
23D	P-9025	<u>PIVOT STUD</u> - 15 THOUSANDTHS .015 OVERSIZED. <i>SEE NOTE.</i>
24	P-496	<u>LOCKNUT</u>
25	P-36831	<u>PRESSURE BLOCK</u> - (369 ARMS ONLY)
26	P-1583	<u>ALLEN HEAD CAP SCREW</u> - NEEDED ONLY ON 369 PRESSES.
27	P-36833	<u>LOWER SUPPORT ARM</u> - AVAILABLE ONLY WITH 9/16" HOLE.
28	P-36753	<u>PRESSURE BLOCK ASSEMBLY</u> - MOUNTS TO SIDE FRAME.
	P-98753	<u>PRESSURE BLOCK ASSEMBLY</u> - MOUNTS TO SIDE FRAME. 9800 QP, QPC & PRO.
29	P-401	<u>ROLL PIN</u> - 350, 360 & 375 BLOCK.
	P-406	<u>ROLL PIN</u> - 9800 BLOCK.
30	P-36835	<u>SCREW</u> - USE WITH ITEMS #31 TO #32. FOR 1/2" HOLE.
	P-8041	<u>SCREW</u> - USE WITH ITEMS #31 TO #32D & P-36833. FOR 9/16" HOLE.
31	P-9026	<u>PIVOT STUD</u> - FOR ARMS WITH 1/2" HOLE. USE WITH P-36835.
	P-9047	<u>PIVOT STUD</u> - FOR ARMS WITH 9/16" HOLE. USE WITH P-8041 & P-36833.
32A	P-9027	<u>PIVOT STUD</u> - 3 THOUSANDTHS .003 OVERSIZED. FOR ARMS WITH 1/2" HOLE. USE WITH P-36835. <i>SEE NOTE.</i>
	P-9048	<u>PIVOT STUD</u> - 3 THOUSANDTHS .003 OVERSIZED. FOR ARMS WITH 9/16" HOLE. USE WITH P-8041 & P-36833. <i>SEE NOTE.</i>
32B	P-9028	<u>PIVOT STUD</u> - 5 THOUSANDTHS .005 OVERSIZED. FOR ARMS WITH 1/2" HOLE. USE WITH P-36835. <i>SEE NOTE.</i>
	P-9049	<u>PIVOT STUD</u> - 5 THOUSANDTHS .005 OVERSIZED. FOR ARMS WITH 9/16" HOLE. USE WITH P-8041 & P-36833. <i>SEE NOTE.</i>
32C	P-9029	<u>PIVOT STUD</u> - 10 THOUSANDTHS .010 OVERSIZED. FOR ARMS WITH 1/2" HOLE. USE WITH P-36835. <i>SEE NOTE.</i>
	P-9050	<u>PIVOT STUD</u> - 10 THOUSANDTHS .010 OVERSIZED. FOR ARMS WITH 9/16" HOLE. USE WITH P-8041 & P-36833. <i>SEE NOTE.</i>
32D	P-9030	<u>PIVOT STUD</u> - 15 THOUSANDTHS .015 OVERSIZED. FOR ARMS WITH 1/2" HOLE. USE WITH P-36835. <i>SEE NOTE.</i>
	P-9051	<u>PIVOT STUD</u> - 15 THOUSANDTHS .015 OVERSIZED. FOR ARMS WITH 9/162" HOLE. USE WITH P-8041 & P-36833. <i>SEE NOTE.</i>
33	P-958	<u>HEX HEAD BOLT</u>
34	P-629	<u>SPLIT LOCKWASHER</u> - NOT NEEDED IF USED WITH P-506 FLANGED HEX NUT.
35	P-506	<u>HEX NUT</u> - USE WITH ITEM #34 THIS PAGE OR USE P-505.
	P-505	<u>HEX NUT</u> - FLANGED.
36	P-953	<u>SHOULDER BOLT</u>
37	P-492	<u>HEX NUT</u>
38	P-524	<u>LOCKNUT</u> - NYLOCK.
39	P-6031	<u>SPRING ANCHOR</u> - USE ONLY ON 369 PRESSES.
40	P-133	<u>SCREW</u>
41	P-36851	<u>SPACER</u>
42	P-36853	<u>HOUSING ASSEMBLY</u> - 350 & 360. (S/N 197057 & ABOVE).
	OBSOLETE	<u>HOUSING ASSEMBLY</u> - 350 & 360. (S/N 197056 & BELOW).
	P-37853	<u>HOUSING ASSEMBLY</u> - 375 & 9800.
43	P-1305	<u>BUSHING</u> - NEW STYLE FOR 350, 360. (S/N 197057 & ABOVE).
	P-1362	<u>BUSHING</u> - OLD STYLE FOR 350, 360. (S/N 197056 & BELOW).
	P-1363	<u>BUSHING</u> - 375, 9800.
44	P-1485	<u>COLLAR</u>
45	P-27	<u>SET SCREW</u>
46	P-709	<u>RETAINING RING</u>
47	P-36857	<u>MASTER CYLINDER SHAFT</u> - 350, 360 & 369. SUPPORT ARM ITEM #18 THIS PAGE, ITEM #1, PAGE 43. GOES THROUGH ITEMS #1 ON PAGE 15, 16 & 17.
	P-98857	<u>MASTER CYLINDER SHAFT</u> - 9800. SUPPORT ARM ITEM #18 THIS PAGE, ITEM #1, PAGE 43. GOES THROUGH ITEMS #1 ON PAGE 15, 16 & 17.
48	P-5948	<u>CYLINDER SHAFT PULLER</u> - FOR MASTER & IMPRESSION CYLINDER. SEE PAGE 41.
<p><u>NOTE:</u> - IF YOUR CYLINDER SUPPORT ARMS ARE WORN, YOU CAN EASILY REPLACE JUST THE STUD USING AN ADJUSTABLE REAMER P-1550. BORE OUT THE HOLE AND INSERT THE NEXT SIZE STUD. IT'S SIMPLE AND SAVES YOU MONEY! SEE PAGE 15, 16, 17 &amp; 17A FOR MASTER CYLINDER.</p>		

**DRAWING #43**  
**MASTER CYLINDER POWER LEVER & LATCH**

OPERATORS SIDE  
ONLY

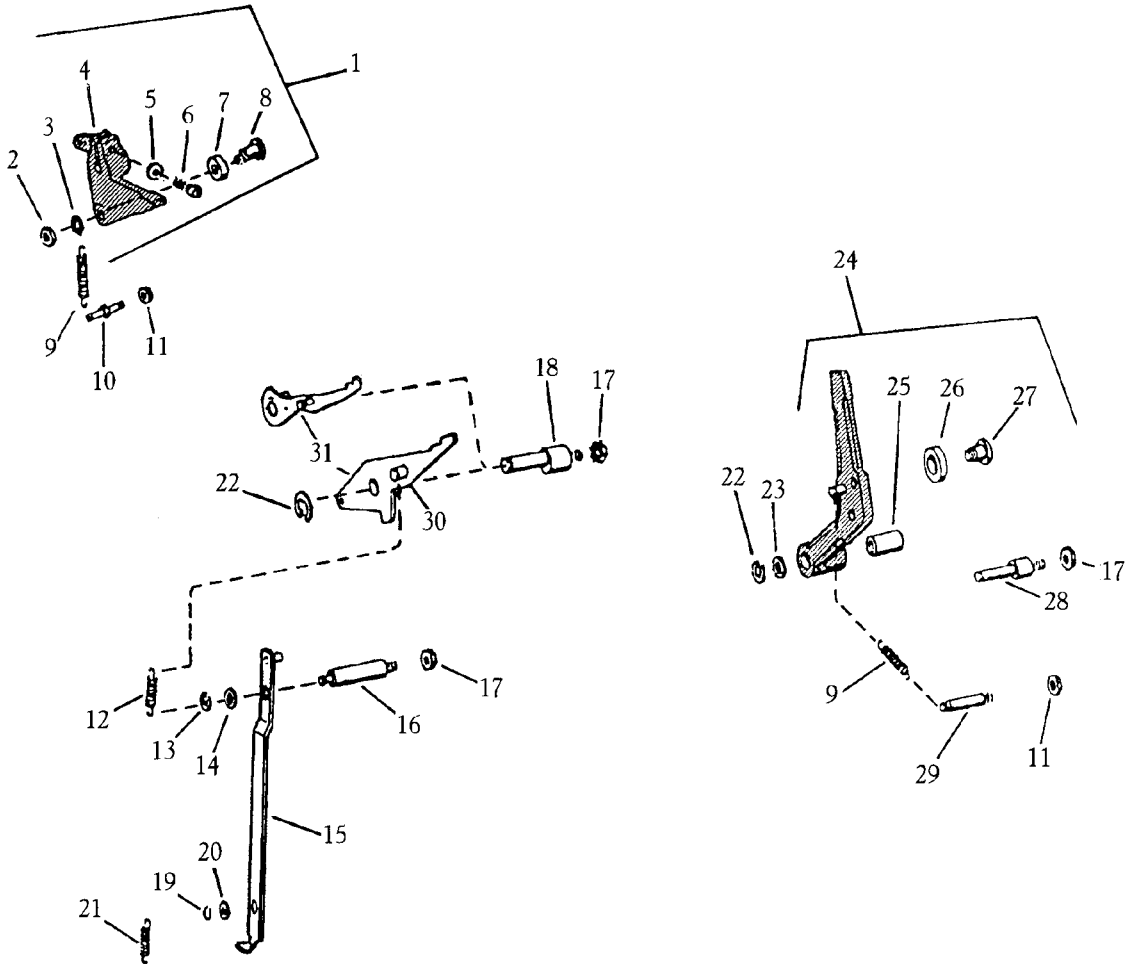
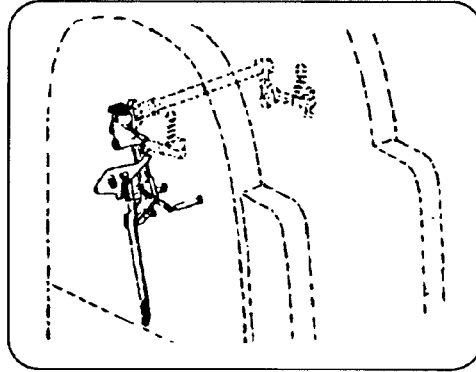

**PAGE #43**  
**MASTER CYLINDER POWER LEVER & LATCH**

KEY #	PART#	DESCRIPTION
1	P-36827	<u>LEVER ASSEMBLY</u> - 350 & 360 - ATTACHES TO ITEM #47, PAGE 42.
	P-37827	<u>LEVER ASSEMBLY</u> - 375 - ATTACHES TO ITEM #47, PAGE 42.
	P-98827	<u>LEVER ASSEMBLY</u> - 9800 - ATTACHES TO ITEM #47, PAGE 42.
2	P-486	<u>NUT</u>
3	P-635	<u>LOCKWASHER</u>
4	P-36861	<u>LEVER</u>
	P-37861	<u>LEVER</u>
	P-98861	<u>LEVER</u>
5	P-583	<u>WASHER</u>
6	P-57	<u>CAP SCREW</u>
7	P-1462	<u>CAM ROLLER</u> - RIDES ON LEVER #24.
8	P-8022	<u>ECCENTRIC SHOULDER SCREW</u>
9	P-36032	<u>SPRING</u> - SEE ITEM #39, PAGE 46 & ITEM #4, THIS PAGE.
9A	P-36213	<u>SPRING</u> - (STRONGER TENSION FOR 369 PRESSES)
	P-37213	<u>SPRING</u>
10	P-6010	<u>SPRING ANCHOR</u> - SEE ITEM #39, PAGE 46.
11	P-471	<u>LOCK NUT</u>
12	P-36798	<u>SPRING</u>
13	P-668	<u>C-RING</u>
14	P-586	<u>WASHER</u>
15	P-36865	<u>LINK</u> - BOTTOM END CONNECTS TO LEVER ITEM #19, PAGE 35.
	P-36869	<u>LINK</u> - 369 MODELS
16	P-6025	<u>SPRING ANCHOR</u>
	P-6050	<u>SPRING ANCHOR</u> - 9800 ONLY
17	P-487	<u>KEPS NUT</u>
18	P-9032	<u>ECCENTRIC STUD</u> - MOUNTS INTO SIDE FRAME. SEE ITEM #40, PAGE 46.
19	P-699	<u>RETAINING RING</u>
20	P-596	<u>WASHER</u>
21	P-36266	<u>SPRING</u>
22	P-670	<u>C-RING</u>
23	P-604	<u>WASHER</u>
24	P-36875	<u>POWER LEVER ASSEMBLY</u>
25	P-826	<u>BUSHING</u>
26	P-1463	<u>CAM ROLLER</u> - FOR CAM SEE ITEM #33, PAGE 14
27	P-8020	<u>SHOULDER SCREW</u>
28	P-9033	<u>PIVOT STUD</u> - MOUNTS INTO SIDE FRAME.
29	P-6024	<u>SPRING ANCHOR</u>
30	P-36881	<u>LATCH</u> - 350/360/375/9800 FOR OPERATING ARM SEE ITEM #9, PAGE 14
31	P-36883	<u>LATCH</u> - 369 FOR OPERATING ARM SEE ITEM #9, PAGE 14

**DRAWING #44**  
**BUCKLE & CAM SHAFT ASSEMBLY**

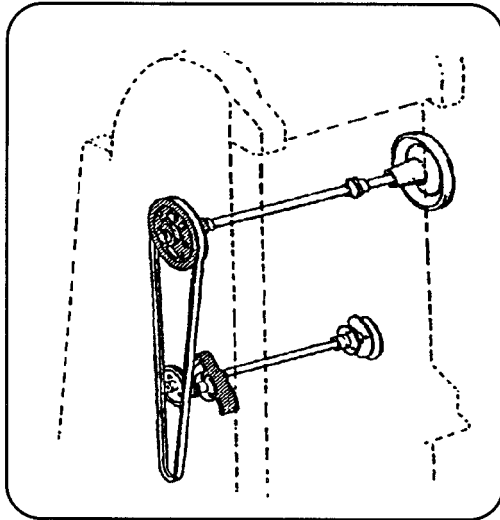

**OPERATORS SIDE**

**NON-OPERATORS SIDE**

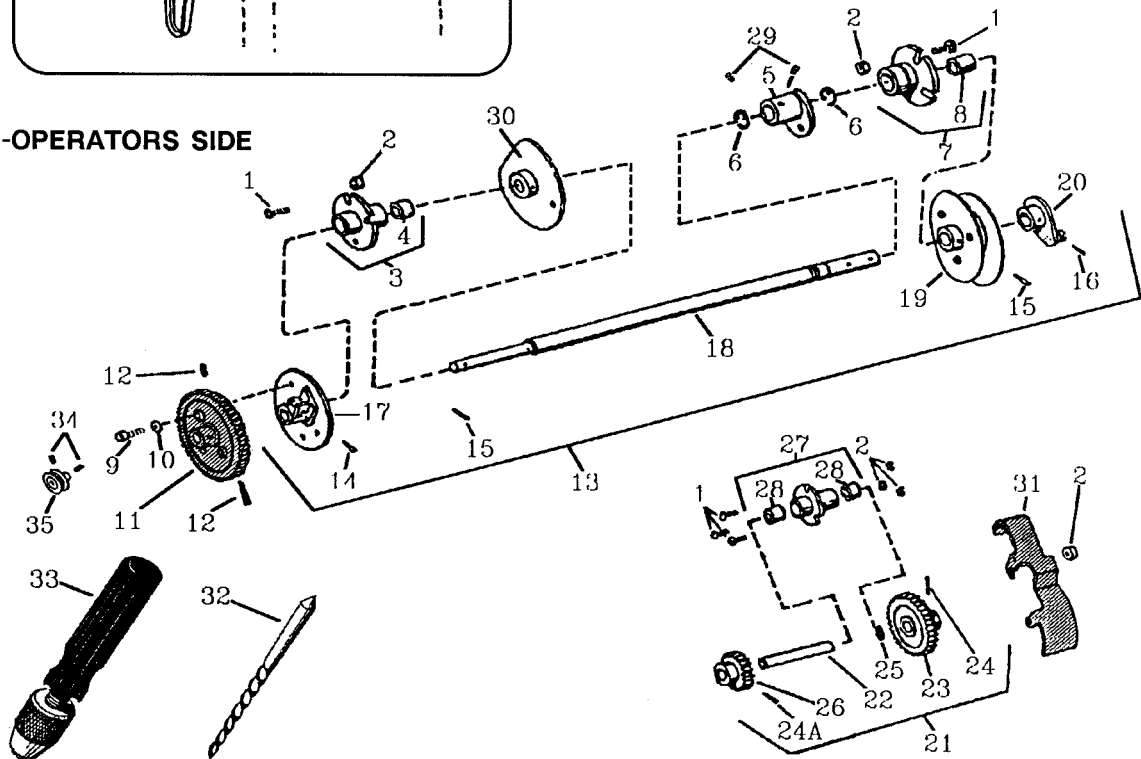

**PAGE #44**  
**BUCKLE & CAM SHAFT ASSEMBLY**

KEY #	PART#	DESCRIPTION
1	P-263	<u>SCREW</u>
2	P-471	<u>NUT</u>
3	P-36724	<u>HOUSING ASSEMBLY</u> - NON OPERATORS SIDE.
4	P-828	<u>BUSHING</u>
5	P-36732	<u>CAM ASSEMBLY</u> - CHAIN DELIVERY ONLY, SEE ITEM #30, THIS PAGE FOR CHUTE DELIVERY.
6	P-673	<u>E-RING</u> - NEEDED FOR CHAIN DELIVERY.
7	P-36726	<u>HOUSING ASSEMBLY</u> - (NEW STYLE) OPERATORS SIDE. OLD STYLE WITH BUSHING IS OBSOLETE. NEW STYLE HAS NO BUSHING. BUSHING IS AVAILABLE SEPARATELY FOR OLD STYLE ONLY.
8	P-1264	<u>BUSHING</u>
9	P-277	<u>SCREW</u>
10	P-590	<u>WASHER</u>
11	P-36728	<u>GEAR</u> - OPERATED BY GEAR, ITEM #21 THIS PAGE.
12	P-13	<u>SCREW</u>
13	P-36738	<u>CAM &amp; SHAFT ASSEMBLY</u> - CHAIN DEL. - (DOES NOT COME WITH #5, THIS PAGE. MUST ORDER SEPARATELY)
	P-37738	<u>CAM &amp; SHAFT ASSEMBLY</u> - CHAIN DEL. - (DOES NOT COME WITH #5, THIS PAGE. MUST ORDER SEPARATELY)
	P-98736	<u>CAM &amp; SHAFT ASSEMBLY</u> - CHUTE DEL. - (COMES WITH #30, THIS PAGE.)
	P-98738	<u>CAM &amp; SHAFT ASSEMBLY</u> - CHAIN DEL. - (DOES NOT COME WITH #5, THIS PAGE. MUST ORDER SEPARATELY)
	P-98727	<u>CAM &amp; SHAFT ASSEMBLY</u> - CHUTE DEL. - HALL EFFECT (DOES NOT COME WITH #5, THIS PAGE, MUST ORDER SEPARATELY)
	P-98728	<u>CAM &amp; SHAFT ASSEMBLY</u> - CHAIN DEL. - HALL EFFECT (COMES WITH #30 THIS PAGE)
	P-36736	<u>CAM &amp; SHAFT ASSEMBLY</u> - CHUTE DEL. - (COMES WITH #30, THIS PAGE)
	P-37736	<u>CAM &amp; SHAFT ASSEMBLY</u> - CHUTE DEL. - (COMES WITH #30, THIS PAGE)
	P-36734	<u>CAM &amp; SHAFT ASSEMBLY</u> - (369)
14	P-434	<u>TAPER PIN</u>
15	P-436	<u>TAPER PIN</u>
16	P-443	<u>TAPER PIN</u>
17	P-36741	<u>CAM</u> - CHAIN DELIVERY & CHUTE DELIVERY, NOT SOLD SEPARATELY, SEE P-36736 OR P-36738, SEE ITEM #26, PAGE 5.
18	P-36723	<u>SHAFT</u> - 350-360
	P-37723	<u>SHAFT</u> - 375 (NOT SOLD SEPARATELY, USE P-37736 OR P-37738)
	P-98723	<u>SHAFT</u> - 9800 (NOT SOLD SEPARATELY, USE P-98736 OR P-98723)
19	P-36742	<u>DOUBLE CAM</u> - NOT SOLD SEPARATELY FOR 350 OR 360, SEE P-36734, P-36736, P-36738. OPERATES ITEM #1, PAGE 9, & ITEM 23A, PAGE 9. SEE ITEM #5, PAGE 38.
	NO#	<u>DOUBLE CAM</u> - NOT SOLD SEPARATELY FOR 375, P-37736, P-37738. OPERATES ITEM #1, PAGE 9, & ITEM 23A, PAGE 9. SEE ITEM #5, PAGE 38
	NO#	<u>DOUBLE CAM</u> - NOT SOLD SEPARATELY FOR 9800, P-98736, P-39838. OPERATES ITEM #1, PAGE 9, & ITEM 23A, PAGE 9. SEE ITEM #5, PAGE 38
	NO #	<u>TRIPLE CAM</u> - (369), NOT SOLD SEPARATELY, SEE P-36734.
20	NO #	<u>LEVER</u> - NOT SOLD SEPARATELY, SEE P-36734, P-36736, P-36738. CONNECTS TO ITEM #1, PAGE 39.
	NO #	<u>LEVER</u> - NOT SOLD SEPARATELY, P-37736, P-37738. CONNECTS TO ITEM #1, PAGE 39.
	NO #	<u>LEVER</u> - NOT SOLD SEPARATELY, P-98736, P-98738. CONNECTS TO ITEM #1, PAGE 39.
21	P-36752	<u>GEAR SHAFT ASSEMBLY</u> - 350, 360, 375 & 9800. CHUTE DELIVERY
	P-36754	<u>GEAR SHAFT ASSEMBLY</u> - 350, 360 & 375. CHAIN DELIVERY
	P-98754	<u>GEAR SHAFT ASSEMBLY</u> - 9800 CHAIN DELIVERY.
22	P-36750	<u>SHAFT</u> - CHUTE DELIVERY
	P-36746	<u>SHAFT</u> - CHAIN DELIVERY
23	P-36756	<u>GEAR</u> - CHUTE DELIVERY, SEE ITEM #26, PAGE 32.
	P-36758	<u>GEAR</u> - CHAIN DELIVERY, SEE ITEM #26, PAGE 32.
24	P-386	<u>ROLL PIN</u>
24A	P-428	<u>TAPER PIN</u>
25	P-1432	<u>SPECIAL SPACER</u> - NOT NEEDED FOR P-36754 CHAIN DELIVERY SHAFT ASSEMBLY.
26	P-36748	<u>GEAR</u> - CHUTE DELIVERY, OPERATES GEAR, ITEM #11, THIS PAGE. MUST HAVE PROPER TOOLS. HAND REAMER P-1546 & REAMER BIT P-1547.
	P-36745	<u>GEAR</u> - CHAIN DELIVERY, OPERATES WITH ITEM #11, THIS PAGE. MUST HAVE PROPER TOOLS. HAND REAMER P-1546 & REAMER BIT P-1547.
27	P-36640	<u>HOUSING ASSEMBLY</u> - ALL MODELS. CHUTE & CHAIN DELIVERY.
28	P-822	<u>BUSHING</u>
29	P-26	<u>SET SCREW</u> - NEEDED FOR CHAIN DELIVERY - 2 NEEDED.
30	NO #	<u>CAM</u> - CHUTE DELIVERY, NOT SOLD SEPARATELY, SEE P-36736, SEE ITEM #5, THIS PAGE FOR CHAIN DELIVERY CAM.
31	P-36740	<u>GUARD</u>
32	P-1546	<u>HAND REAMER</u>
33	P-1547	<u>REAMER BIT</u>
34	P-5	<u>SET SCREW</u>
35	P-1742	<u>PULLEY</u> - DRIVES ITEM #34, PAGE 52.

**DRAWING #45**  
**SIDE FRAMES (UPPER INK) & RELATED PARTS**

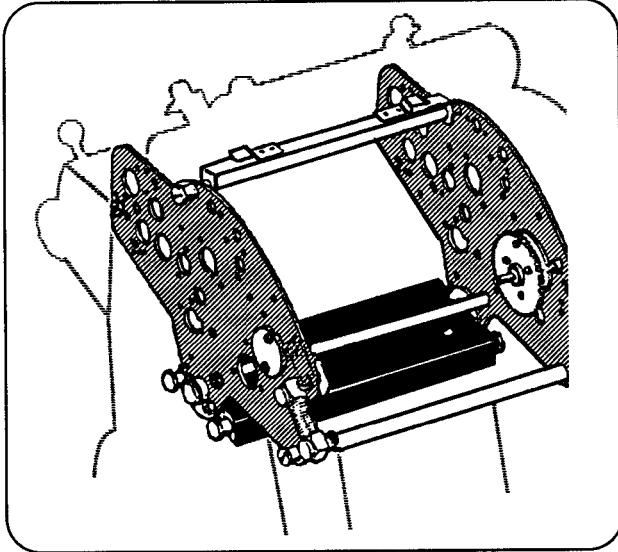

**NON-OPERATORS SIDE**

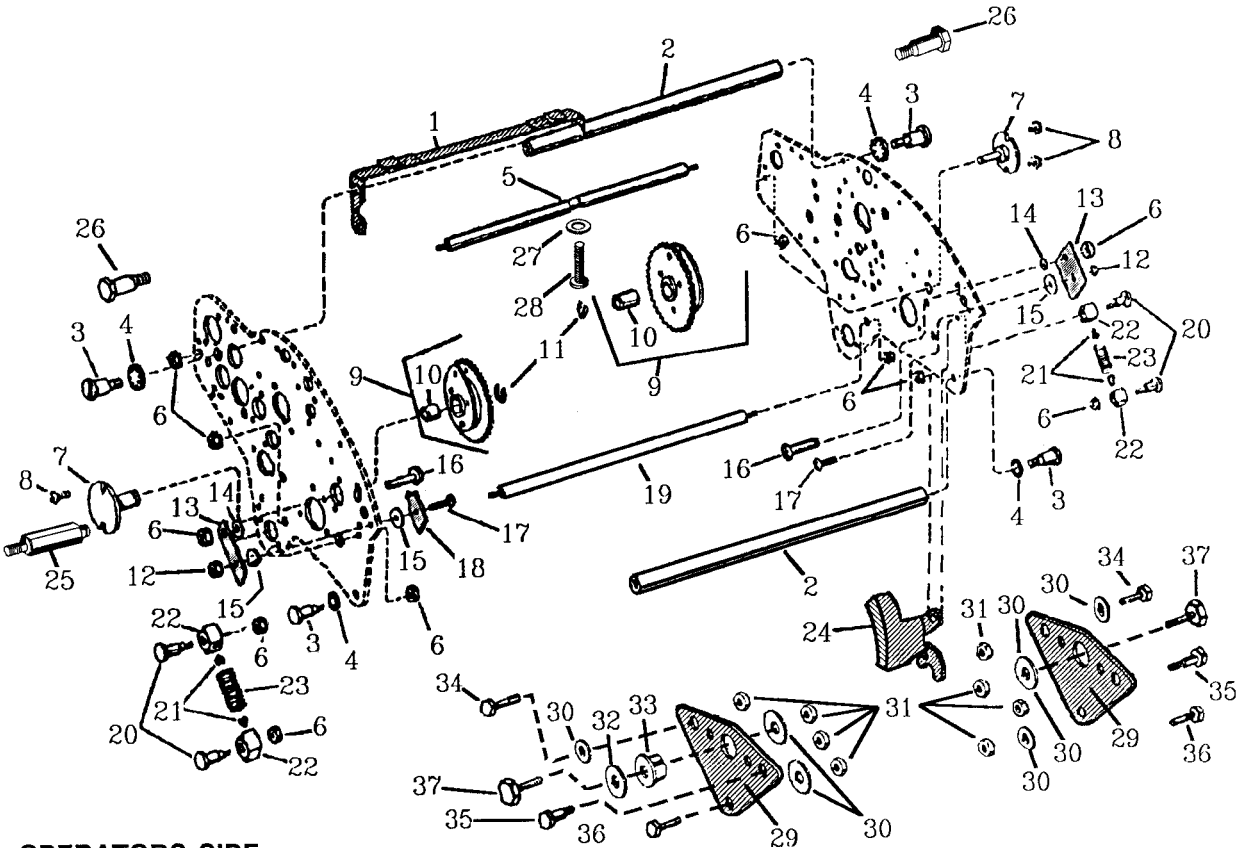

**OPERATORS SIDE**



**PAGE #45**  
**SIDE FRAMES (UPPER INK) & RELATED PARTS**

KEY #	PART#	DESCRIPTION
1	P-36862	<u>WAVER ROLLER REST ASSEMBLY</u>
	P-37862	<u>WAVER ROLLER REST ASSEMBLY</u>
2	P-36643	<u>TIE BAR</u> - OBSOLETE. USE TIE BAR P-36635 ITEM #2 THIS PAGE. MUST ALSO USE P-8012 SHOULDER SCREW ITEM #3 THIS PAGE. FRAME MUST ALSO BE DRILLED OUT TO 3/8" HOLE.
	P-98643	<u>TIE BAR</u> - UPPER SIDE FRAME.
	P-36864	<u>TIE BAR</u> - PRO MODELS WITH SAFETY GUARD FRAMES.
	P-36635	<u>TIE BAR</u> - UPPER SIDE FRAME (350 S/N 196800 - 360 S/N 197057 AND ABOVE - 369 S/N/ 232724 AND ABOVE).
	P-37635	<u>TIE BAR</u> - SAME AS ITEM #19 FOR 375.
3	P-8012	<u>SHOULDER SCREW</u> - (350 S/N 196800 - 360 S/N 197057 AND ABOVE. INCLUDES PRO MODELS. - 369 S/N 232724 AND ABOVE).
	P-8052	<u>SHOULDER SCREW</u>
4	P-647	<u>LOCKWASHER</u>
5	P-36641	<u>TIE BAR</u> - UPPER SIDE FRAME (350 S/N 196799 - 360 S/N 197056 AND BELOW).
	P-37641	<u>TIE BAR</u> - UPPER SIDE FRAME (INTERNAL THREADS) SEE SPRING ANCHOR CLIP, ITEM #39 PAGE 28.
	P-98641	<u>TIE BAR</u> - UPPER SIDE FRAME. SEE SPRING ANCHOR CLIP, ITEM #39 PAGE 28.
	P-36645	<u>TIE BAR</u> - UPPER SIDE FRAME (350 S/N 196800 - 360 S/N 197057 AND ABOVE) INCLUDES PRO MODELS.
6	P-489	<u>NUT</u>
7	P-36872	<u>STUD BEARING</u> SEE ITEM #16 PAGE 37.
8	P-271	<u>SCREW</u>
9	P-36360	<u>CAM &amp; GEAR ASSEMBLY</u> - OLD DESIGN HAS HUB ON CAM THAT FITS INTO THE FRAME. RUNS ON GEAR #15 PAGE 16 OR ITEM #46 PAGE 15 & CAM ROLLER ITEM #15 PAGE 20.
	P-36358	<u>CAM &amp; GEAR ASSEMBLY</u> - NEW DESIGN (NO HUB ON CAM, BOTH SIDES ARE FLAT) INCLUDES 369 MODELS. RUNS GEAR ITEM #15 PAGE 16 OR ITEM #46 PAGE 15 & CAM ROLLER ITEM #15 PAGE 20.
10	P-825	<u>BUSHING</u> - USED WITH P-36360 ITEM #9 THIS PAGE.
	P-824	<u>BUSHING</u> - USED WITH P-36358 ITEM #9 THIS PAGE.
11	P-670	<u>SNAP RING</u>
12	P-471	<u>KEPS NUT</u>
13	P-36882	<u>GUIDE</u> - OLD DESIGN. THIS DESIGN HAS 2 HOLES. MODELS USING THIS DESIGN NEED 1 PER SIDE.
	P-36884	<u>GUIDE</u> - NEW DESIGN. THIS DESIGN HAS 1 HOLE WITH A STUD PROTRUDING. MODELS USING THIS DESIGN NEED 4, 2 PER SIDE.
14	P-582	<u>WASHER</u>
15	P-1538	<u>WASHER</u> - USE WITH SCREW P-264 ITEM #17 THIS PAGE.
	P-582	<u>WASHER</u> - USE WITH SCREW P-944 ITEM #17 THIS PAGE.
16	P-277	<u>GUIDE SCREW</u>
17	P-264	<u>GUIDE SCREW</u> - FOR 350, 360 & OLD DESIGN PRO MODELS.
	P-944	<u>GUIDE SCREW</u> - NEW DESIGN PRO MODELS. USE P-487 NUT.
18	P-36886	<u>GUIDE</u> - USED WITH GUIDES P-36882. 1 PER SIDE.
19	P-36655	<u>TIE BAR</u> - UPPER SIDE FRAME (350 S/N 196799 - 360 S/N 197056 AND BELOW) FOR MACHINES WITHOUT GAP CONTROL
	P-36635	<u>TIE BAR</u> - UPPER SIDE FRAME (350 S/N 196800 - 360 S/N 197057 AND ABOVE. INCLUDES PRO MODELS) FOR MACHINES WITH GAP CONTROL.
	P-37635	<u>TIE BAR</u> - UPPER SIDE FRAME. FOR MACHINES WITH GAP CONTROL.
	P-36659	<u>TIE BAR</u> - UPPER SIDE FRAME (369 S/N 232723 AND BELOW).
	P-36645	<u>TIE BAR</u> - UPPER SIDE FRAME (369 S/N 232724 AND ABOVE).
20	P-8024	<u>ECCENTRIC SHOULDER SCREW</u> - USED WITH BLOCK P-36868 - 350 & 360.
	P-8025	<u>SHOULDER SCREW</u> - 369 ONLY. USED WITH BLOCK P-36870.
	P-8026	<u>SHOULDER SCREW</u> - FOR LOWER SPRING BLOCK ON 369 ONLY.
21	P-36874	<u>SCREW</u>
22	P-36868	<u>SPRING BLOCK</u> - USED WITH SCREW P-36866.
	P-36870	<u>SPRING BLOCK</u> - USED WITH SCREW P-36872. 369 MODELS.
23	P-36876	<u>COMPRESSION SPRING</u>
24	P-36878	<u>GEAR GUARD</u> - 350 & 360 MODEL S/N 269142 AND ABOVE. INCLUDES ALL PRO MODELS.
25	P-36806	<u>PIVOT STUD</u> - SEE ITEM #16 PAGE 37 OR ITEM #7 THIS PAGE.
26	P-8053	<u>SHOULDER SCREW</u> - 9800 MODEL TIE BARS ONLY.
27	P-1557	<u>THUMB NUT</u> - 9800 MODEL ONLY.
28	P-85	<u>SCREW</u>
29	P-37669	<u>MOUNTING PLATE</u> - USED IN PLACE OF TIE BAR ITEM #21 PAGE 46.
30	P-620	<u>WASHER</u>
31	P-505	<u>NUT</u>
32	P-621	<u>WASHER</u>
33	P-36331	<u>ECCENTRIC HOUSING KIT</u> - SEE ITEM #9 PAGE 46.
34	P-8054	<u>SHOULDER SCREW</u>
35	P-8055	<u>SHOULDER SCREW</u>
36	P-338	<u>BOLT</u>
37	P-36571	<u>SHOULDER BOLT</u>

**DRAWING #46**  
**SIDE FRAMES (UPPER & LOWER), TIE BARS & FRAME MOUNTS**

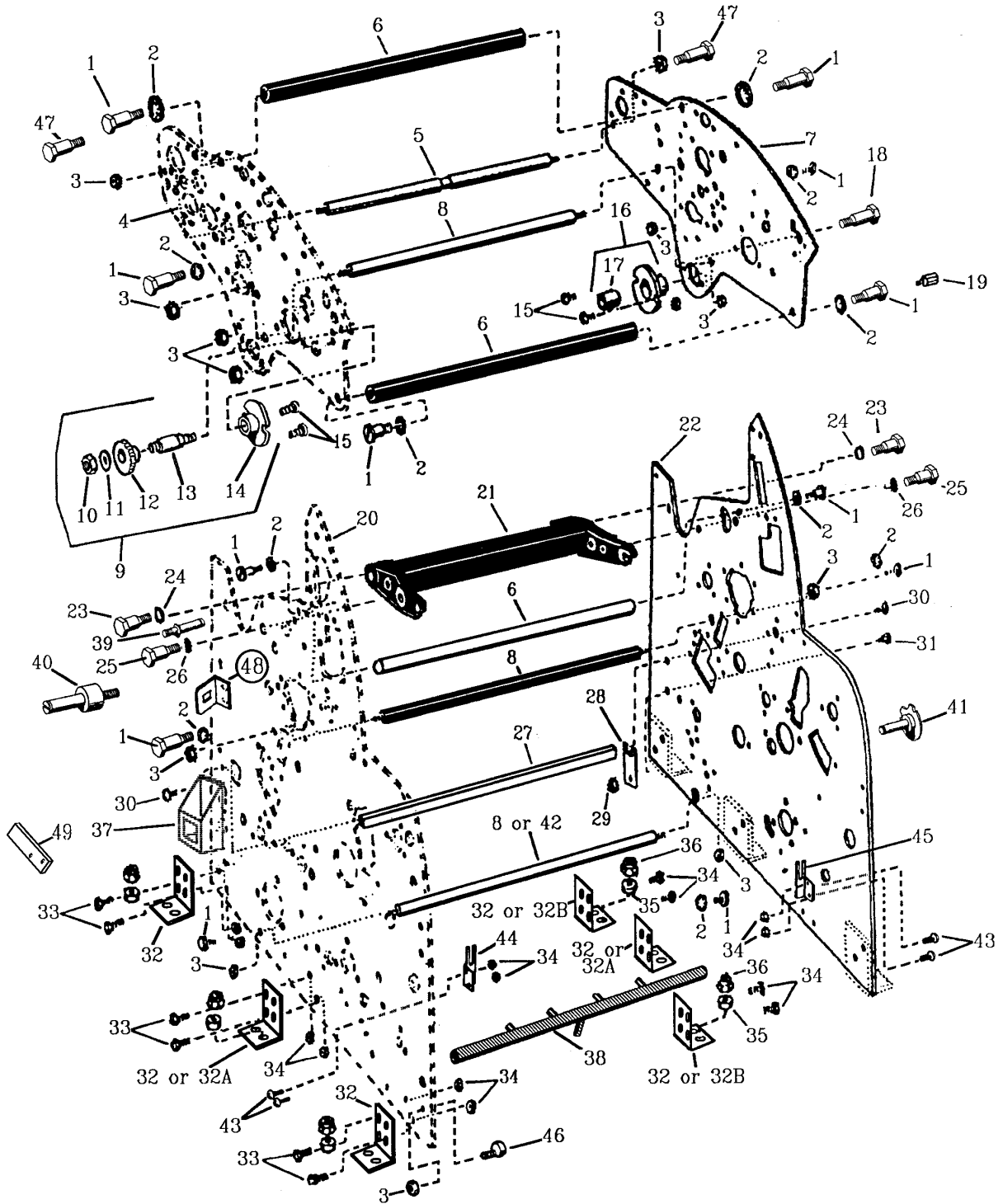

**PAGE #46**  
**SIDE FRAMES (UPPER & LOWER), TIE BARS & FRAME MOUNTS**

KEY #	PART#	DESCRIPTION
1	P-8012	<u>SHOULDER SCREW</u> - USE WITH TIE BAR P-36657 IF YOUR FRAME HAS A 3/8 IN. HOLE.
	P-8052	<u>SHOULDER SCREW</u> - FOR 9800 ONLY.
2	P-667	<u>LOCKWASHER</u> - USE WITH P-8009, ITEM #1, THIS PAGE.
3	P-487	<u>LOCK NUT</u>
4	P-35633	<u>UPPER SIDE FRAME</u> - (OPERATORS SIDE) FOR 350 S/N #196799, 360 S/N #197056. AND LOWER.
	OBSOLETE	<u>UPPER SIDE FRAME</u> - (OPERATORS SIDE) FOR 369 S/N #232723, AND LOWER.
	P-36633	<u>UPPER SIDE FRAME</u> - (OPERATORS SIDE) FOR 350 S/N #196800, AND 360 S/N #197057, AND HIGHER.
	P-37633	<u>UPPER SIDE FRAME</u> - (OPERATORS SIDE) FOR 375.
	P-36639	<u>UPPER SIDE FRAME</u> - (OPERATORS SIDE) FOR 369 S/N #232724, AND HIGHER.
	P-98633	<u>UPPER SIDE FRAME</u> - (OPERATORS SIDE) FOR 9800.
5	P-36641	<u>TIE BAR</u> - USE WITH P-35633 FOR 350. P-36633 FOR 360 & P-36635 FOR 369.
	P-37641	<u>TIE BAR</u> - USE WITH P-37633 & P-37635 FOR 375.
	P-36645	<u>TIE BAR</u> - USE WITH P-36647 FOR 350 & 360, & P-36639 FOR 369.
	P-98641	<u>TIE BAR</u> - USE WITH P-98633 & P-98635 FOR 9800, THIS PAGE.
6	P-36643	<u>TIE BAR</u> - OBSOLETE. USE P-36335 TIE BAR. ITEM #6. THIS PAGE & 8012 SHOULDER SCREW ITEM #1. THIS PAGE. FRAME MUST ALSO BE DRILLED OUT TO 3/8" HOLE.
	P-36635	<u>TIE BAR</u> - USE WITH P-36647 FOR 350 & 360, & P-36639 FOR 369.
	P-37635	<u>TIE BAR</u> - USE WITH P-37633 FOR 375 & P-98633 FOR 9800/P-37647 FOR 375 & P-98647 FOR 9800.
	P-98643	<u>TIE BAR</u> - USE WITH P-98633 FOR 9800, THIS PAGE.
7	P-36647	<u>UPPER SIDE FRAME</u> - (NON-OPERATORS SIDE) FOR 350 S/N #196799, AND 360 S/N #197056, AND LOWER.
	P-37647	<u>UPPER SIDE FRAME</u> - (NON-OPERATORS SIDE)
	P-36649	<u>UPPER SIDE FRAME</u> - (NON-OPERATORS SIDE) FOR 369 S/N #232723, AND LOWER.
	P-36651	<u>UPPER SIDE FRAME</u> - (NON-OPERATORS SIDE) FOR 350 S/N #196000, 360 S/N #197051, AND HIGHER.
	P-36639	<u>UPPER SIDE FRAME</u> - (NON-OPERATORS SIDE) FOR 369 S/N #232724, AND HIGHER.
	P-98647	<u>UPPER SIDE FRAME</u> - (NON-OPERATORS SIDE)
8	P-36655	<u>TIE BAR</u> - USE WITH P-35633 FOR 350, P-36633 FOR 360 (FOR MACHINES WITHOUT GAP CONTROL)
	P-37655	<u>TIE BAR</u> - USE WITH P-37671 & P-98671 FOR 375 & 9800.
	P-36635	<u>TIE BAR</u> - USE WITH P-36647 FOR 350 & 360 (FOR MACHINES WITH GAP CONTROL)
	P-37635	<u>TIE BAR</u> - USE WITH P-37633 FOR 375 & P-98633 FOR 9800/P-37647 FOR 375 & P-98647 FOR 9800, THIS PAGE.
	P-36659	<u>TIE BAR</u> - USE WITH (ITEM #4) FOR 369 OLD STYLE.
	P-36645	<u>TIE BAR</u> - USE WITH P-36639 (ITEM #7) FOR 369 NEW STYLE.
9	P-36631	<u>PIVOT &amp; HOUSING ASSEMBLY KIT</u> - MOST 369 PRESSES ARE EQUIPPED WITH A DIFFERENT STYLE HOUSING, BUSHING, BOLT AND WASHER. THIS STYLE KIT CAN BE USED ON ALL 350, 360, 369, AND PRO MODELS.
10	P-506	<u>NUT</u>
11	P-601	<u>WASHER</u> - (NOT AVAILABLE SEPARATELY FOR 369)
12	P-36629	<u>ECCENTRIC BUSHING</u> - (NOT AVAILABLE SPARATELY FOR 369)
13	P-36571	<u>PIVOT STUD</u>
14	P-36567	<u>ECCENTRIC HOUSING</u>
15	P-263	<u>SCREW</u>
16	P-36557	<u>HOUSING ASSEMBLY</u> - NEED 3 NUTS, P-471 IF YOU ARE REPLACING THE STYLE WITH THREADED INSERTS.
17	P-1261	<u>BUSHING</u>
18	P-8013	<u>SHOULDER BOLT</u>
19	P-36663	<u>SPECIAL COUPLING SCREW</u> - USE WITH P-36635 (ITEM #6) ON 369 ONLY.
	P-36665	<u>SPECIAL COUPLING SCREW</u> - USE WITH P-36643 (ITEM #6) ON 369 ONLY.
20	P-36667	<u>LOWER MACHINE FRAME</u> - (OPERATORS SIDE) FOR ALL 350, 360. 360 PRO & 369 PRESSES.
	P-37667	<u>LOWER MACHINE FRAME</u> - (OPERATORS SIDE) FOR 375.
	P-98667	<u>LOWER MACHINE FRAME</u> - (OPERATORS SIDE) FOR 9800 PRESSES.
21	P-36669	<u>UPPER &amp; LOWER CONNECTING TIE BAR</u> - SEE NOTE.
22	P-36671	<u>LOWER MACHINE FRAME</u> - (NON-OPERATORS SIDE) FOR ALL 350, 360, 360 PRO & 369 PRESSES.
	P-37671	<u>LOWER MACHINE FRAME</u> - (NON-OPERATORS SIDE) FOR 375 PRESSES.
	P-98671	<u>LOWER SIDE FRAME</u> - (OPERATORS SIDE) FOR 9800 PRESSES.
23	P-8015	<u>MOUNTING BOLT</u>
24	P-649	<u>LOCKWASHER</u>
25	P-8016	<u>MOUNTING BOLT</u>
26	P-639	<u>LOCKWASHER</u>
27	P-36677	<u>TIE BAR</u>
	P-37677	<u>TIE BAR</u>
20	P-36679	<u>LOCKING BRACKET</u>
29	P-462	<u>KEPS NUT</u>
30	P-273	<u>SCREW</u>
31	P-8017	<u>SHOULDER SCREW</u>
32	P-36683	<u>MOUNTING BRACKET</u> - FOR 350-360-375.
	P-98603	<u>MOUNTING BRACKET</u> - 9800 ONLY (OPERATORS SIDE)
32A	P-98681	<u>MOUNTING BRACKET</u> - 9800 ONLY (CENTER)
32B	P-98684	<u>MOUNTING BRACKET</u> - 9800 ONLY (NON-OPERATORS SIDE)
33	P-943	<u>SCREW</u> - SEE NOTE, PAGE 50 FOR MOUNTING LAMP BRACKET.
34	P-471	<u>NUT</u>
35	P-36615	<u>SPECIAL WASHER</u>
36	P-525	<u>LOCK NUT</u>
37	P-36047	<u>HOUSING</u> - SEE ITEM #54, PAGE 1.
30	P-36064	<u>HEADER SHAFT</u> - SEE ITEM #3, PAGE 4.
	P-37064	<u>HEADER SHAFT</u> - SEE ITEM #3. PAGE 4.
39	P-6010	<u>SPRING ANCHOR</u> - SEE ITEM #10, PAGE 43.
40	P-9032	<u>ECCENTRIC STUD</u> - SEE ITEM #18, PAGE 43.
41	P-36539	<u>BEARING STUD</u>
42	P-37655	<u>TIE BAR</u> - 375 & 9000
43	P-278	<u>SCREW</u>
44	P-36700	<u>GUARD</u>
45	P-36701	<u>GUARD</u>
46	P-7017	<u>HEIGHT REGULATOR SCREW</u> - FOR PILE HEIGHT REGULATOR CONTROL.
47	P-8053	<u>SHOULDER SCREW</u> - 9800 ONLY.
48	P-98492	<u>FEED SWITCH BRACKET</u>
49	P-36545	<u>NUT PLATE</u> - ATTACHES TO ITEM #32, BENEATH ITEM #37. <b>NOTE:</b> 375 & 9800 MODELS USE SUPPORT PLATES IN PLACE OF TIE BAR, ITEM #21, THIS PAGE. FOR DIAGRAM SEE PAGE 45.

**DRAWING #47**  
**COVERS - UPPER SIDE, FEED & INK COVERS & COUNTER ASSEMBLY**  
**350, 360, 375**

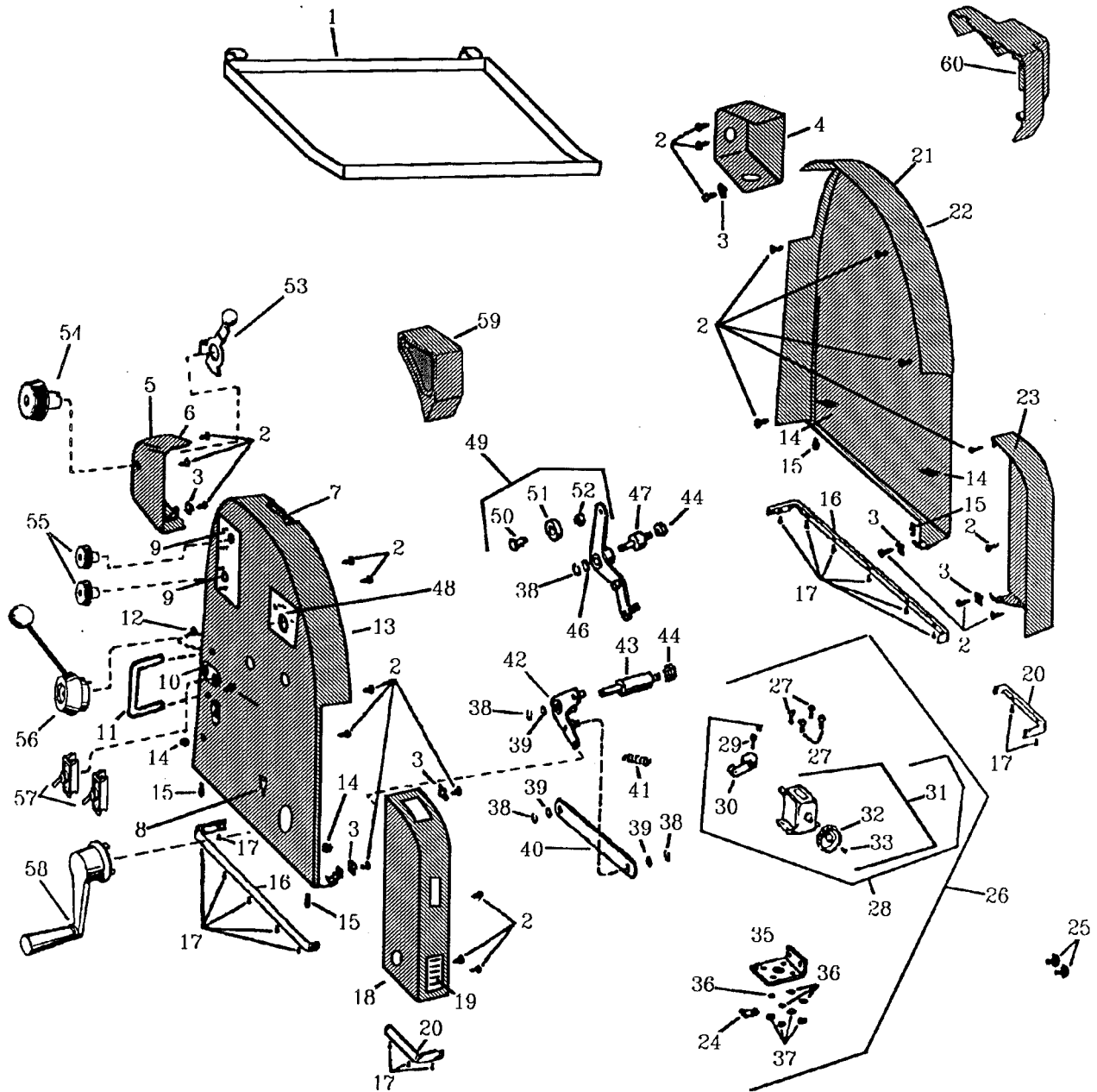

SEE PAGE 47A FOR 9800

## COVERS - UPPER SIDE, FEED &amp; INK COVERS &amp; COUNTER ASSEMBLY - 350, 360, 375

KEY #	PART#	DESCRIPTION
1	P-36982	<u>SPLASH PAN</u> - 369 MODELS S/N #45143 AND ABOVE
2	P-964	<u>SCREW</u>
3	P-530	<u>SPEED NUT</u>
4	P-36928	<u>INK COVER</u> - NON-OPERATORS SIDE - BROWN.
5	P-36892	<u>DECAL</u> - INK CONTROL - 5 POSITION. SEE NOTE .
	P-36912	<u>DECAL</u> - INK CONTROL - 11 POSITION, SEE NOTE.
6	P-36890	<u>INK COVER</u> - (OPERATORS SIDE) 5 POSITION LEVER - 350, 360, 369 - BROWN.
	P-36908	<u>INK COVER</u> - (OPERATORS SIDE) 11 POSITION LEVER - 360 PRO - BROWN.
7	P-36894	<u>DECAL</u> - WATER CONTROL, SEE NOTE.
8	P-36896	<u>DECAL</u> - BUCKLE ADJUSTING & WATER CONTROL, SEE NOTE.
9	P-36898	<u>DECAL</u> - FORM ROLL, ON & OFF, SEE NOTE.
10	P-36980	<u>SWITCH PLATE</u> - MOTOR & VACUUM W/AUTO POS.
	P-36902	<u>SWITCH PLATE</u> - OLD DESIGN, 220V. 50/60 HZ.
11	P-36904	<u>SWITCH GUARD</u> - 360, PRO, QP & QPC
12	P-205	<u>SCREW</u> - 2 NEEDED
13	OBSOLETE	<u>SIDE COVER</u> - OPERATOR SIDE, FOR 350/360, PRIOR TO SINGLE LEVER CONTROL.
	P-36914	<u>SIDE COVER</u> - OPERATOR SIDE, FOR MODELS WITH SINGLE LEVER CONTROL - BROWN.
	P-37914	<u>SIDE COVER</u> - OPERATOR SIDE, FOR MODELS WITH SINGLE LEVER CONTROL - BROWN.
14	P-462	<u>NUT</u> - 350 & 360 MODELS FROM S/N 235602
15	P-6032	<u>PIVOT</u> - 350 & 360 MODELS FROM S/N 235602
16	P-36906	<u>SIDE COVER TRIM</u> - 1 PER SIDE.
17	P-974	<u>SCREW</u>
	P-966	<u>SCREW</u> - PRO, QP & QPC
18	P-36920	<u>FEED CONTROL COVER</u> - OPERATOR SIDE - BROWN.
	P-37920	<u>FEED CONTROL COVER</u> - OPERATOR SIDE - BROWN.
19	P-36922	<u>DECAL</u> - FEED HEIGHT ADJUSTMENT S/N 440715 & ABOVE, SEE NOTE.
	P-36924	<u>DECAL</u> - SHEET FEED QP & QPC, SEE NOTE.
20	P-36926	<u>FEED COVER TRIM</u> - 1 PER SIDE
21	P-36888	<u>DECAL</u> - NIGHT LATCH - ON & OFF, SEE NOTE.
22	P-36930	<u>SIDE COVER</u> - (NON-OPERATORS SIDE) - FOR MODELS WITH SINGLE LEVER CONTROL - BROWN.
23	P-36936	<u>FEED COVER</u> - (NON-OPERATORS SIDE) - BROWN, ALL MACHINES.
24	P-36948	<u>CLAMP</u> - HOLDS CABLE, ITEM #11, PAGE 38, UNDER COUNTER BRACKET.
25	P-260	<u>SCREW</u>
26	P-36996	<u>COUNTER AND BRACKET ASSEMBLY</u>
27	P-229	<u>SCREW</u>
28	P-36952	<u>COUNTER ASSEMBLY</u>
29	P-151	<u>SCREW</u>
30	P-36956	<u>COUNTER LEVER</u> - 350, 360 & 375. INCLUDES ITEM #29. SEE ITEM #42, THIS PAGE TO TRIP COUNTER.
	P-32956	<u>COUNTER LEVER</u> - 320
31	P-36954	<u>COUNTER</u>
32	P-36958	<u>RESET WHEEL</u> - SCREW ON STYLE. MUST HAVE TAPPED HOLE IN COUNTER SHAFT.
	P-36963	<u>RESET WHEEL</u> - PLASTIC SNAP ON TYPE.
33	P-1056	<u>SCREW</u>
35	P-36950	<u>COUNTER BRACKET</u>
36	P-641	<u>WASHER</u>
37	P-1139	<u>NUT</u>
38	P-669	<u>RETAINING RING</u>
39	P-595	<u>WASHER</u>
40	P-36940	<u>COUNTER LINK</u> - ATTACHES TO ITEM #42 & #49, THIS PAGE.
41	P-36938	<u>TENSION SPRING</u>
42	P-36942	<u>COUNTER LEVER ASSEMBLY</u> - TRIPS ITEM #30, & CONNECTS TO ITEM #40, THIS PAGE.
43	P-9037	<u>C-RING ANCHOR</u>
44	P-487	<u>NUT</u>
46	P-595	<u>WASHER</u>
47	P-9039	<u>C-RING ANCHOR</u> - ATTACHES TO SIDE FRAME
48	P-36900	<u>DECAL</u> - SINGLE LEVER CONTROL, SEE NOTE.
49	P-36988	<u>CAM LEVER ASSEMBLY</u> - 350 & 360 MODELS. OPERATES ON CAM #33, PAGE 14. OPERATED BY ITEM #19, PAGE 35.
	P-36984	<u>CAM LEVER ASSEMBLY</u> - 369 MODELS
50	P-1593	<u>RIVET</u>
51	P-1463	<u>ROLLER</u>
52	P-1579	<u>BUSHING</u>
53	P-36269	<u>RATCHET LEVER</u> - SEE ITEM 3, PAGE 29A.
	P-36259	<u>RATCHET LEVER</u> - SEE ITEM 3, PAGE 29B.
54	P-36242	<u>INK FOUNTAIN KNOB</u> - SEE ITEM 14, PAGE 29A OR ITEM 1, PAGE 29B.
55	P-36405	<u>FORM ROLL KNOB</u> - SEE ITEM 4A & 4B, PAGE 22 OR ITEM 3A OR 3B, PAGE 23.
56	P-36856	<u>SINGLE LEVER CONTROL</u> - SEE ITEM 41, PAGE 37.
57	P-36977	<u>SWITCH</u> - SEE ITEM 26, PAGE 48A.
58	P-36955	<u>HAND CRANK</u> - SEE ITEM 36, PAGE 39.
59	OBSOLETE	<u>COVER</u> - 369 ONLY. CONTROL PANEL.
60	OBSOLETE	<u>COVER</u> - 369 ONLY. ETCHER MOTOR.

**NOTE:** TO APPLY DECALS IT IS NOT NECESSARY TO USE CEMENT.  
DIP DECALS IN UNIVERSAL FOUNTAIN SOLUTION FOR ONLY 45-60 SECONDS.  
PLACE AND WIPE WITH "LITE" RAG OR DAMP SPONGE. LET STAND UNTIL ALMOST DRY, THEN SLIDE OFF BACKING.

**DRAWING #47A**  
**COVERS - UPPER SIDE & INK - 9800 SERIES**

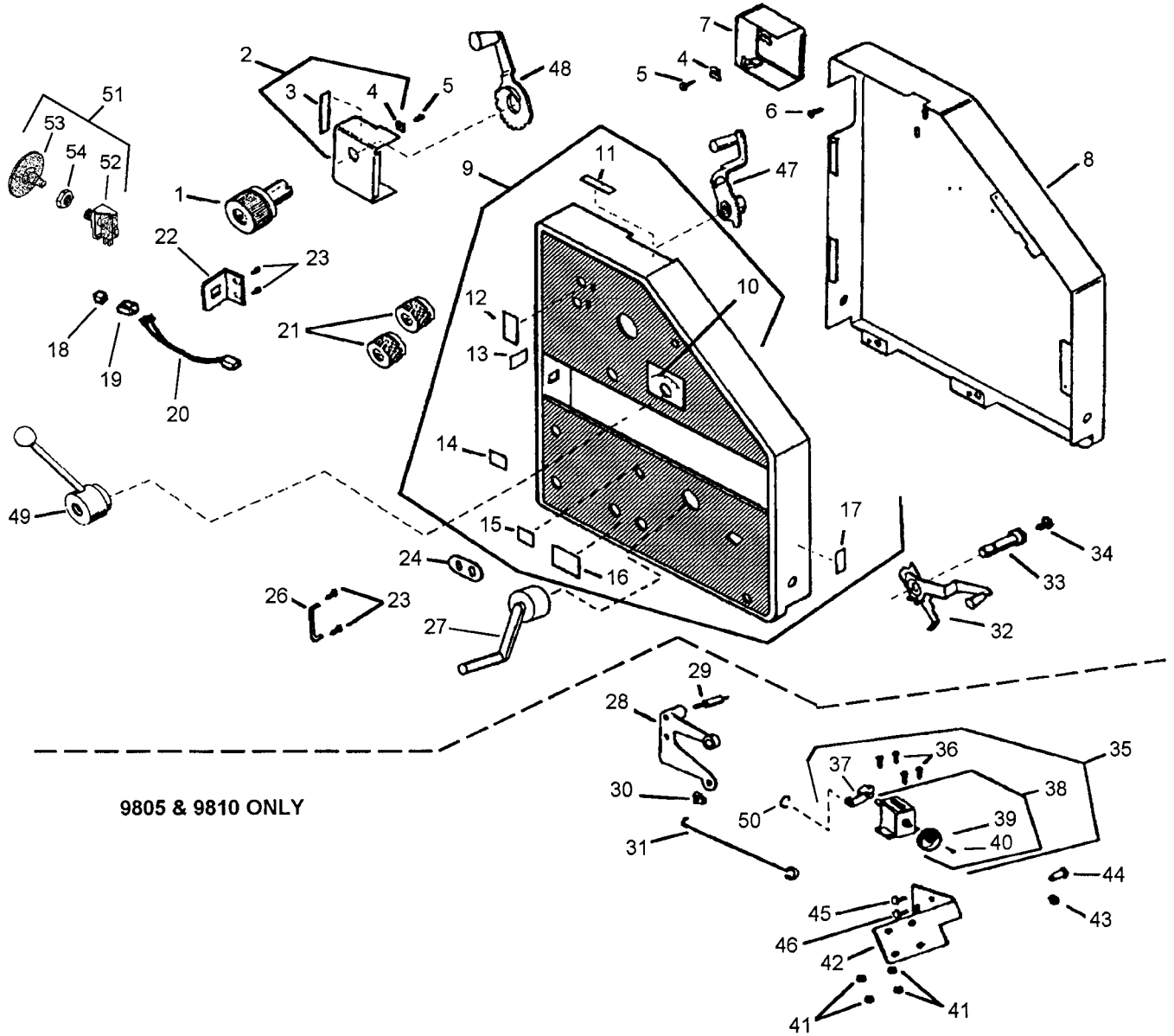

9805 & 9810 ONLY

**PAGE #47A**  
**COVERS - UPPER SIDE & INK - 9800 SERIES**

KEY #	PART#	DESCRIPTION
1	P-98242	<u>INK FOUNTAIN KNOB</u> - 9800 ONLY. SEE ITEM #30, PAGE 29C or ITEM #43, PAGE 14.
2	P-98908	<u>INK COVER</u> - COMES WITH ITEMS #3 & 4.
3	P-98892	<u>DECAL</u> - INK CONTROL LEVER - 11 POSITION.
4	P-530	<u>SPEED NUT</u>
5	P-964	<u>SCREW</u> - OLD DESIGN.
6	P-262	<u>SCREW</u>
7	P-98928	<u>INK COVER</u> - NON-OPERATORS SIDE.
8	P-98930	<u>SIDE COVER ASSEMBLY</u> - NON-OPERATORS SIDE.
9	P-98914	<u>SIDE COVER ASSEMBLY</u> - OPERATORS SIDE - DOES NOT INCLUDE ITEMS #18, 19 & 20 THIS PAGE.
10	P-98900	<u>DECAL</u> - OPERATION CONTROL, QP, QPC & PRO.
11	P-36900	<u>DECAL</u> - OPERATION CONTROL, TD & CD.
	P-98894	<u>DECAL</u> - WATER CONTROL.
12	P-36898	<u>DECAL</u> - FORM ROLLERS, QP, QPC & PRO.
	P-98898	<u>DECAL</u> - FORM ROLLERS, TD & CD.
13	P-98980	<u>DECAL</u> - ON/OFF - AUX. FEED.
14	P-98046	<u>DECAL</u> - SPEED CONTROL.
15	P-36896	<u>DECAL</u> - BUCKLE ADJUSTING, TD, CD, QP, QPC & PRO.
16	P-36960	<u>DECAL</u> - AIR & VACUUM, TD, CD, QP, QPC & PRO.
17	P-36922	<u>DECAL</u> - PAPER HEIGHT REGULATOR.
18	P-4026	<u>LENS</u> - FEED SWITCH.
19	P-4030	<u>SWITCH</u> - FEED, TD & QP.
	P-4033	<u>SWITCH</u> - FEED, TD & QP (OLD DESIGN)
20	P-4034	<u>CABLE ASSEMBLY</u> - FEED, TD & QP.
21	P-98031	<u>FORM ROLL KNOB</u> - 9800 SERIES ONLY. SEE ITEM #4C, PAGE 22 or ITEM #3C, PAGE 23.
22	P-98492	<u>BRACKET</u> - FEED SWITCH. MOUNTS TO SIDE FRAME, SEE ITEM #48, PAGE 46.
23	P-943	<u>SCREW</u>
24	P-36980	<u>SWITCH PLATE</u> - 9805-9810.
25	P-204	<u>SCREW</u> - FOR SWITCH GUARD, ITEM #26 THIS PAGE.
26	P-36904	<u>SWITCH GUARD</u> - 9805-9810.
27	P-98955	<u>HAND CRANK</u> - FEED TABLE RAISING & LOWERING. 9800 SERIES ONLY. SEE ITEM #36, PAGE 39.
28	P-98942	<u>COUNTER OPERATING LEVER</u> - 9805 & 9810 ONLY.
29	P-9039	<u>C-RING ANCHOR</u>
30	P-98946	<u>CLIP</u>
31	P-98940	<u>ROD</u> - 9805-9810. OPERATES COUNTER LEVER ITEM #37, THIS PAGE.
32	P-98905	<u>FEED CONTROL LEVER</u> - OPERATES ITEM #62, PAGE 38.
33	P-8050	<u>STUD</u>
34	P-91	<u>SCREW</u>
35	P-36952	<u>COUNTER ASSEMBLY</u> - 350, 360, 369, 375, 9805 & 9810.
36	P-229	<u>SCREW</u>
37	P-36956	<u>COUNTER ARM</u>
38	P-36954	<u>COUNTER</u>
39	P-36963	<u>RESET WHEEL</u>
40	P-1056	<u>SCREW</u>
41	P-456	<u>NUT</u>
42	P-98950	<u>BRACKET</u> - COUNTER MOUNT. 9805-9810.
43	P-472	<u>NUT</u>
44	P-1726	<u>ADAPTER NUT</u>
45	P-943	<u>SCREW</u>
46	P-86	<u>SCREW</u>
47	P-98416	<u>WATER CONTROL LEVER</u> - SEE ITEM #29, PAGE 20.
48	P-98259	<u>INK CONTROL LEVER</u> - SEE ITEM #1, PAGE 29C.
49	P-98856	<u>OPERATION CONTROL LEVER</u> - 9800 SERIES ONLY. - SEE ITEM #41, PAGE 37.
50	P-726	<u>RETAINING RING</u>
51	P-4057	<u>EMERGENCY STOP SWITCH</u> - 9800 SERIES.
52	P-9806	<u>SWITCH ONLY</u>
53	P-7206	<u>RED STOP BUTTON</u>





**PAGE #48**  
**COVERS - BASE, REAR & RIGHT HAND PANEL DOOR - ALL MODELS**

KEY #	PART#	DESCRIPTION
1	P-36981	<u>REAR COVER</u> - FOR 350 & 360 OLD STYLE AND NEW STYLE - BROWN.
	P-37981	<u>REAR COVER</u> - FOR 375 OLD AND NEW STYLE - BROWN.
	P-98981	<u>REAR COVER</u> - FOR 9800 OLD AND NEW STYLE - BROWN.
2	P-36934	<u>BASE COVER</u> - (OPERATORS SIDE) NEW STYLE FOR 369, 360 PRO & 375 - BROWN.
	P-36998	<u>BASE COVER</u> - (OPERATORS SIDE) FOR 360 PRO - BROWN.
	P-98934	<u>BASE COVER</u> - (OPERATORS SIDE) FOR CHUTE OR CHAIN DELIVERY - BROWN.
	P-98998	<u>BASE COVER</u> - (OPERATORS SIDE) FOR QP, QPC & PRO.
3	P-262	<u>SCREW</u> - 350 & 360.
	P-264	<u>SCREW</u> -375.
4	P-469	<u>NUT</u>
5	P-111	<u>SCREW</u>
6	P-36817	<u>PIN FOR HINGE</u>
7	P-682	<u>RETAINING RING</u>
8	P-36785	<u>BUMPER</u> - 350, 360 & 375.
	P-98785	<u>BUMPER</u> - 9800.
9	P-6026	<u>DOOR CATCH STUD</u>
10	P-632	<u>LOCKWASHER</u>
11	P-466	<u>NUT</u>
12	P-249	<u>SCREW</u>
13	P-462	<u>NUT</u>
14	P-36999	<u>GASKET</u> - 369 PRESSES.
15	P-36968	<u>OIL GUARD</u> - ON 369 PRESSES ONLY.
17	P-36987	<u>BASE COVER</u> - (NON-OPERATORS SIDE) FOR 350, 360, 369 & 375 OLD AND NEW STYLE - BROWN.
	P-98987	<u>BASE COVER</u> - (NON-OPERATORS SIDE) FOR ALL 9800 MODELS.
18	P-530	<u>SPEED NUT</u>
19	P-36989	<u>CLUTCH PULLEY COVER</u> - FOR 350, 360, AND 369 OLD AND NEW STYLE.
20	P-108	<u>SCREW</u>
21	P-583	<u>WASHER</u>
23	P-36993	<u>DOOR HANDLE</u>
24	P-36995	<u>DOOR</u> - NO LONGER AVAILABLE. USE P-37995.
	P-37995	<u>DOOR</u> - FOR 350, 360, 369, & 375 - BROWN.
25	P-36997	<u>DOOR CATCH</u>
26	P-543	<u>SCREW</u>
27	OBSOLETE	<u>TRAY</u> - FOR STANDARD 350 & 360.
28	P-966	<u>SCREW</u>
29	P-36199	<u>NUT PLATE</u> - ON 360 PRO.
30	P-36200	<u>SWITCH</u> - ON 360 PRO.
31	P-36201	<u>SWITCH INSULATOR</u> - ON 360 PRO.
32	P-36197	<u>BRACKET</u>
33	P-189	<u>SCREW</u>
34	P-192	<u>SCREW</u> - FOR OLD STYLE ACTUATOR
	P-966	<u>SCREW</u> - FOR NEW STYLE ACTUATOR
35	P-36994	<u>ACTUATOR</u> - OLD STYLE (DOUBLE PIN)
	P-36991	<u>ACTUATOR</u> - NEW STYLE (SINGLE PIN)
36	P-36986	<u>BASE COVER</u> - (NON-OPERATORS SIDE) HAS NON-REMOVABLE CLUTCH PULLEY COVER.
37	P-299	<u>SCREW</u> -350, 360, 375.
	P-1994	<u>SCREW</u> - 9800.
38	P-36060	<u>CRANK ASSEMBLY</u> - 350, 360, 375. SEE ITEM #28, PAGE 8.
	P-98060	<u>CRANK ASSEMBLY</u> - 9800. SEE ITEM #28, PAGE 8.
39	P-10	<u>SET SCREW</u>
40	P-36061	<u>CRANK &amp; STUD</u> - 350, 360, 375.
	P-98061	<u>CRANK &amp; STUD</u> - 9800
41	P-36410	<u>LOCK SPRING</u> - FOR ALL.
42	P-36062	<u>HANDLE</u> - FOR ALL.
43	P-36960	<u>DECAL</u> - AIR & VACUUM, SEE NOTE.
44	P-36065	<u>BLEEDER VALVE</u> - FOR 350, 360 & 375. SEE ITEM #11, PAGE 4.
	P-36845	<u>BLEEDER VALVE</u> - FOR 369 & 9800. SEE ITEM #1, PAGE 4A.
45	P-1495	<u>O-RING</u> - USE ON 9800 HANDLE ONLY.
46	P-1026	<u>SCREW</u> - FOR 9800 ONLY.
47	P-235	<u>SCREW</u> - FOR 9800 ONLY.
<p><b>NOTE:</b> TO APPLY DECALS IT IS NOT NECESSARY TO USE DECAL CEMENT.  DIP DECALS IN UNIVERSAL FOUNTAIN SOLUTION FOR <u>ONLY 45-60 SECONDS</u>.  ... PLACE AND WIPE WITH "LITE" RAG OR DAMP SPONGE. LET STAND UNTIL ALMOST DRY  ... THEN SLIDE OFF BACKING. NOW YOUR READY TO ENJOY YOUR BEAUTIFUL NEW DECAL.</p>		

**DRAWING #48A**  
**SWITCHES (DRIVE & PUMP) POWER CORD & SWITCH BOX**

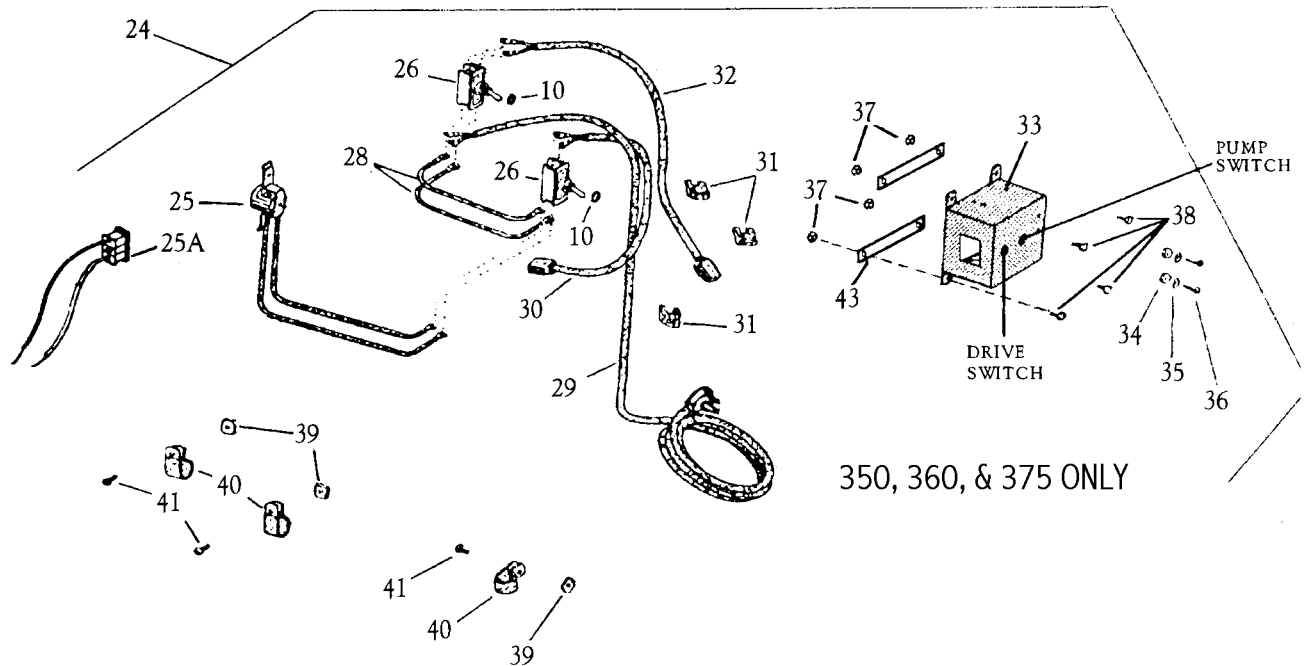
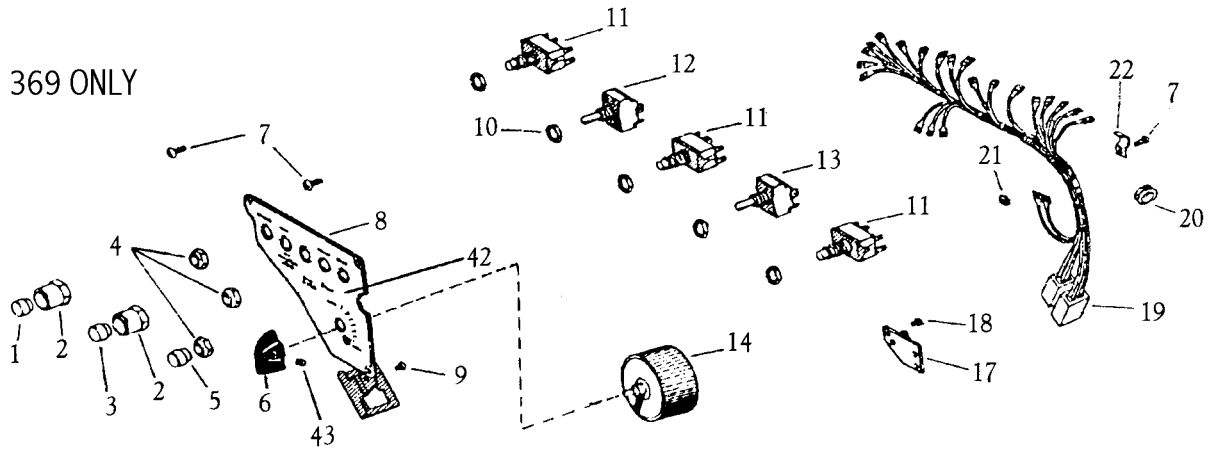

SEE PAGE #51 FOR 9800 CONTROL PANEL, PAGE #48B FOR 360 PRO  
 AND PAGE #48C FOR 9800 PRO.

**PAGE #48A**  
**SWITCHES - (DRIVE & PUMP) POWER CORD & SWITCH BOX**

KEY #	PART#	DESCRIPTION
1	P-36575	<u>BUTTON</u> - (BLACK)
2	P-36293	<u>SWITCH GUARD</u>
3	P--36866	<u>BUTTON</u> - (GREEN)
4	P-1835	<u>MOUNTING NUT</u> - FOR SWITCH.
5	P-36624	<u>BUTTON</u> - (RED)
6	P-36514	<u>TRANSFORMER KNOB</u>
7	P-257	<u>SCREW</u>
8	P-36518	<u>CONTROL PANEL</u>
9	P-203	<u>SCREW</u>
10	P-1834	<u>COLLAR NUT</u>
11	P-36829	<u>SWITCH</u> - PUSH BUTTON.
12	P-36826	<u>TOGGLE SWITCH</u> - 3 TERMINALS & BRIDGE - MOMENTARY.
	P-36066	<u>TOGGLE SWITCH</u> - 6 TERMINALS - MOMENTARY.
13	P-36825	<u>TOGGLE SWITCH</u> - 3 TERMINALS - MOMENTARY.
14	P-36566	<u>VARIABLE TRANSFORMER</u> - (115 V.A.C. - 50/60 Hz.)
17	P-36562	<u>TERMINAL PLATE</u>
18	P-989	<u>SCREW</u>
19	P-36546	<u>CABLE ASSEMBLY</u> - (115 V.A.C. - 50/60 Hz.)
20	P-1837	<u>CABLE TIE</u>
21	P-469	<u>NUT</u>
22	P-1512	<u>CABLE CLAMP</u>
24	P-36216	<u>SWITCH BOX ASSEMBLY</u> - COMPLETE WITH STANDARD SWITCH #P-36977.
25	OBSOLETE	<u>LIGHT RECEPTACLE</u> - (ROUND TYPE) FOR CHUTE DELIVERY. MUST USE NEW SYTLE SWITCH BOX #P-36971. AND NEW STYLE RECEPTACLE #P-36027.
25A	P-36027	<u>LIGHT RECEPTACLE</u> - (SNAP IN TYPE) WORKS ONLY IN NEW STYLE SWITCH BOX. SEE NOTE.
26	P-36977	<u>SWITCH</u> - DRIVE & PUMP, STANDARD SWITCH (SEE ITEM 57, PAGE 47) OLD STYLE.
	P-36303	<u>NEW STYLE DRIVE MOMENTARY SWITCH</u> - (MOTOR) FOR NEWER 360 & 360 PROS.
	P-36305	<u>NEW STYLE TOGGLE SWITCH</u> - (PUMP) FOR 360 & 360 PROS.
28	P-36306	<u>JUMPER CABLE</u>
29	P-4003	<u>POWER CORD</u> - TO WALL PLUG.
30	P-4004	<u>CORD</u> - (VACUUM) ATTATCHES TO PUMP MOTOR CORD ITEM #11, PAGE 2.
31	P-1836	<u>STRAIN RELEIF</u>
	P-4004	<u>CORD</u> - (MOTOR) ATTATCHES TO DRIVE MOTOR CORD ITEM #31, PAGE 1.
33	P-36971	<u>SWITCH BOX</u> - ATTATCHES TO SIDE FRAME ABOVE SPEED CONTROL.
34	P-460	<u>NUT</u>
35	P-562	<u>WASHER</u>
36	P-236	<u>SCREW</u>
38	P-262	<u>SCREW</u>
39	P-532	<u>NUT</u>
40	P-1512	<u>CABLE CLAMP</u>
41	P-973	<u>SCREW</u>
42	P-36519	<u>DECAL</u> - CONTROL PANEL S/N #58105 AND BELOW.
	P-36540	<u>DECAL</u> - CONTROL PANEL S/N #55105 AND ABOVE.
43	P-36271	<u>NUT PLATE &amp; SPACER</u> - USED BEHIND SWITCH BOX - WHEN YOU HAVE A CHAIN DELIVERY.
		<b>NOTE:</b> FOR 360 - THIS STYLE SWITCH BOX ASSEMBLY NEEDS NO CONNECTORS ON SWITCH. SCREWS DIRECTLY ONTO SWITCH. SEE DRAWING 48A.

**DRAWING #48B**  
**SWITCHES - (MOMENTARY) DRIVE & PUMP - 350, 360, 375**

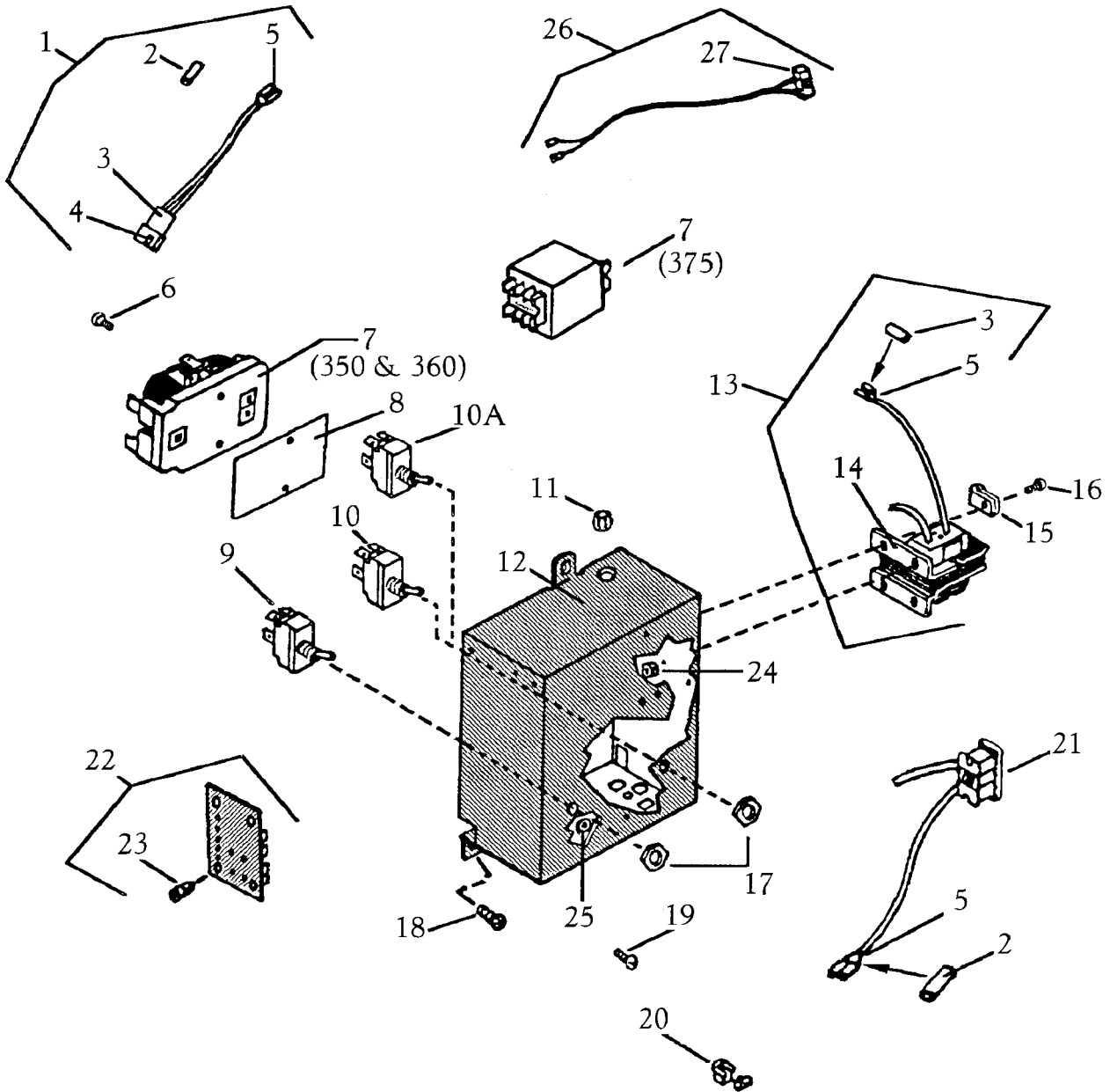

**PAGE #48B**  
**SWITCHES - (MOMENTARY) DRIVE & PUMP - 350, 360, 375**

KEY #	PART#	DESCRIPTION
1	P-36388	<u>CABLE ASSEMBLY</u>
2	P-36467	<u>INSULATOR</u>
3	P-36390	<u>PLUG</u>
4	P-36392	<u>PIN - NEED 2.</u>
5	P-1844	<u>CONNECTOR</u> - CONNECTS TO TERMINAL BOARD ITEM 22, THIS PAGE.
6	P-248	<u>SCREW</u>
7	P-36488	<u>RELAY</u> - 350 & 360 (24 V. - 25 A.) CONNECTS TO TERMINAL BOARD ITEM 22, THIS PAGE. AND MOUNTS TO INSIDE WALL OF SWITCH BOX.
	P-4010	<u>RELAY</u> - 375 (24 V. - 25 A.) CONNECTS TO TERMINAL BOARD ITEM 22, THIS PAGE. AND MOUNTS TO INSIDE WALL OF SWITCH BOX.
8	OBSOLETE	<u>INSULATOR</u>
9	P-36303	<u>TOGGLE SWITCH</u> - MOMENTARY.
10	P-36305	<u>TOGGLE SWITCH</u>
10A	P-36307	<u>TOGGLE SWITCH</u> - WITH NEUTRAL POSITION.
11	P-1518	<u>STRAIN RELIEF</u> - PLASTIC SNAP-IN TYPE.
12	P-36409	<u>SWITCH BOX</u>
13	P-36414	<u>TRANSFORMER ASSEMBLY</u> - (115 V. - 60 Hz.) INCLUDES ITEMS 3 & 6 THIS PAGE.
14	P-36277	<u>TRANSFORMER</u>
15	P-1838	<u>CABLE CLAMP</u>
16	P-259	<u>SCREW</u>
17	P-1834	<u>NUT</u>
18	P-80	<u>SCREW</u>
19	P-236	<u>SCREW</u>
20	P-1644	<u>STRAIN RELIEF</u> - LOCKING TYPE
21	P-36027	<u>LIGHT RECEPTACLE</u> - MUST BUY ITEMS 3 & 5 SEPARATELY. SEE NOTE.
22	P-36395	<u>TERMINAL BOARD ASSEMBLY</u> - MOUNTS TO INSIDE WALL OF SWITCH BOX, ITEM 12, THIS PAGE.
23	P-1843	<u>SPEED NUT</u>
24	P-469	<u>NUT</u>
25	P-461	<u>NUT</u>
26	P-4418	<u>CABLE ASSEMBLY</u> - 360 PRO (LOCATED NEAR FRONT OF PRESS)
27	P-4019	<u>SAFETY SWITCH</u> - 360 PRO (LOCATED NEAR FRONT OF PRESS)
28	P-9782	<u>ACTUATOR</u>
<p><b>NOTE 1:</b> THIS STYLE SWITCH BOX ASSEMBLY NEEDS TERMINAL CONNECTORS FOR ITEM #21 - MUST BUY TERMINALS, INSULATORS &amp; RECEPTACLE. SEE DRAWING #48A.</p> <p><b>NOTE 2:</b> THE GUARDIAN® STYLE RELAY IS OBSOLETE AND IS NO ONGER AVAILABLE. TO USE THE NEW DELTROL® STYLE YOU MUST CUT OFF THE <u>CLIP ON</u> CONNECTORS ATTACHED TO YOUR MACHINES EXISTING WIRES AND WRAP THE ENDS ONTO THE <u>SCREW ON</u> TERMINALS.</p>		

DRAWING #48C  
SWITCHES (DRIVE & PUMP), POWER CORD & SWITCH BOX - 9805, 9810

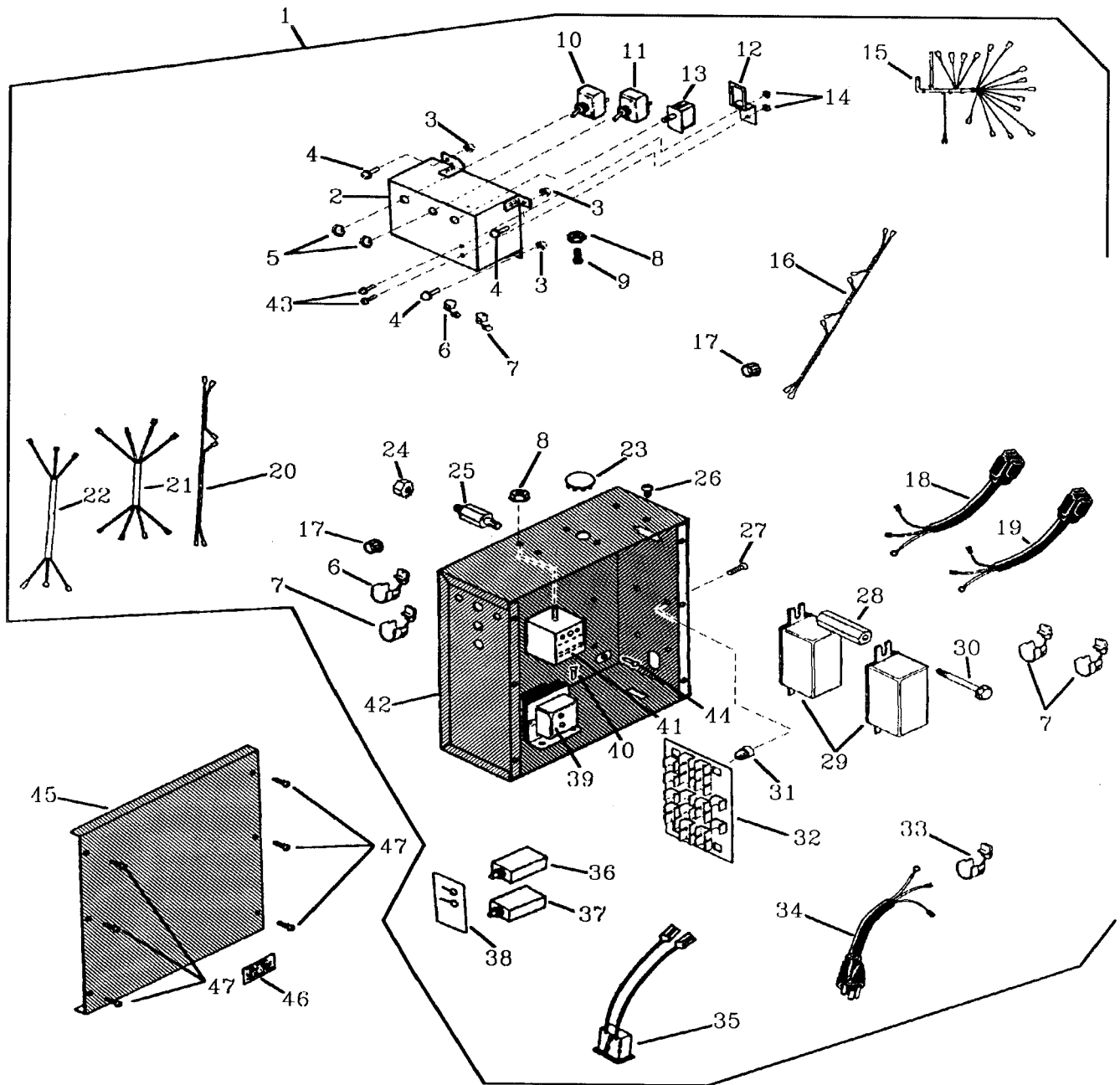

**PAGE #48C**  
**SWITCHES (DRIVE & PUMP), POWER CORD & SWITCH BOX - 9805, 9810**

KEY #	PART#	DESCRIPTION
1	P-98216	<u>SWITCH BOX ASSEMBLY &amp; CONTROL PANEL</u>
2	P-98409	<u>SWITCH BOX</u>
3	P-471	<u>NUT</u>
4	P-81	<u>SCREW</u>
5	P-1834	<u>NUT - SWITCH</u>
6	P-1747	<u>STRAIN RELIEF - LOCKING TYPE. 1/2" O.D.</u>
7	P-1644	<u>STRAIN RELIEF - LOCKING TYPE. 5/8" O.D.</u>
8	P-461	<u>KEPS NUT</u>
9	P-236	<u>SCREW - FOR GROUND WIRE</u>
10	P-36303	<u>NEW STYLE MOMENTARY DRIVE SWITCH</u>
11	P-4021	<u>SWITCH - 2 POSITION (VACUUM)</u>
12	P-98293	<u>BRACKET</u>
13	P-4039	<u>BY-PASS SWITCH</u>
14	P-569	<u>WASHER</u>
15	P-98601	<u>HARNESS ASSEMBLY</u>
16	P-4041	<u>CABLE ASSEMBLY</u>
17	P-1518	<u>STRAIN RELIEF</u>
18	P-4066	<u>CORD - FOR DRIVE MOTOR.</u>
19	P-4065	<u>CORD - FOR COMPRESSOR MOTOR.</u>
20	P-4042	<u>CABLE ASSEMBLY</u>
21	P-4044	<u>CABLE ASSEMBLY - CONNECTS TO DRIVE SWITCH, ITEM #10, THIS PAGE.</u>
22	P-4043	<u>CABLE ASSEMBLY - CONNECTS TO COMPRESSOR SWITCH, ITEM #11, THIS PAGE.</u>
23	P-1727	<u>PLUG</u>
24	P-487	<u>NUT</u>
25	P-7019	<u>STUD - CONTROL BOX MOUNT.</u>
26	P-203	<u>SCREW</u>
27	P-108	<u>TAPPING SCREW</u>
28	P-7020	<u>HEX SPACER</u>
29	P-4037	<u>POWER RELAY - 24 V.A.C.</u>
30	P-1790	<u>SCREW</u>
31	P-1843	<u>EXPANSION NUT</u>
32	P-4045	<u>TERMINAL BOARD</u>
33	P-1757	<u>STRAIN RELIEF</u>
34	P-4046	<u>POWER CORD - 115 V.A.C.</u>
35	P-36027	<u>LIGHT RECEPTACLE - (SNAP IN TYPE)</u>
36	P-4036	<u>CIRCUIT BREAKER - 10 AMP.</u>
37	P-4040	<u>CIRCUIT BREAKER - 15 AMP.</u>
38	P-98960	<u>DECAL - FOR CIRCUIT BREAKER.</u>
39	P-36414	<u>TRANSFORMER ASSEMBLY - 115 V. - 60Hz. (INCLUDES ITEMS #3 &amp; #6, THIS PAGE)</u>
40	P-257	<u>SCREW</u>
41	P-4038	<u>RELAY - 24 V.A.C.</u>
42	P-98410	<u>CONTROL BOX</u>
43	P-215	<u>SCREW</u>
44	P-204	<u>SCREW</u>
45	P-98995	<u>COVER - FOR CONTROL BOX.</u>
46	P-98855	<u>DECAL - FOR WORK LAMP.</u>
47	P-966	<u>TAPPING SCREW</u>

**DRAWING #49**  
**BASE FRAMES AND BOTTOM TIE BARS**

**MOTOR & COMPRESSOR**  
**BASE (SEE PAGE 2)**

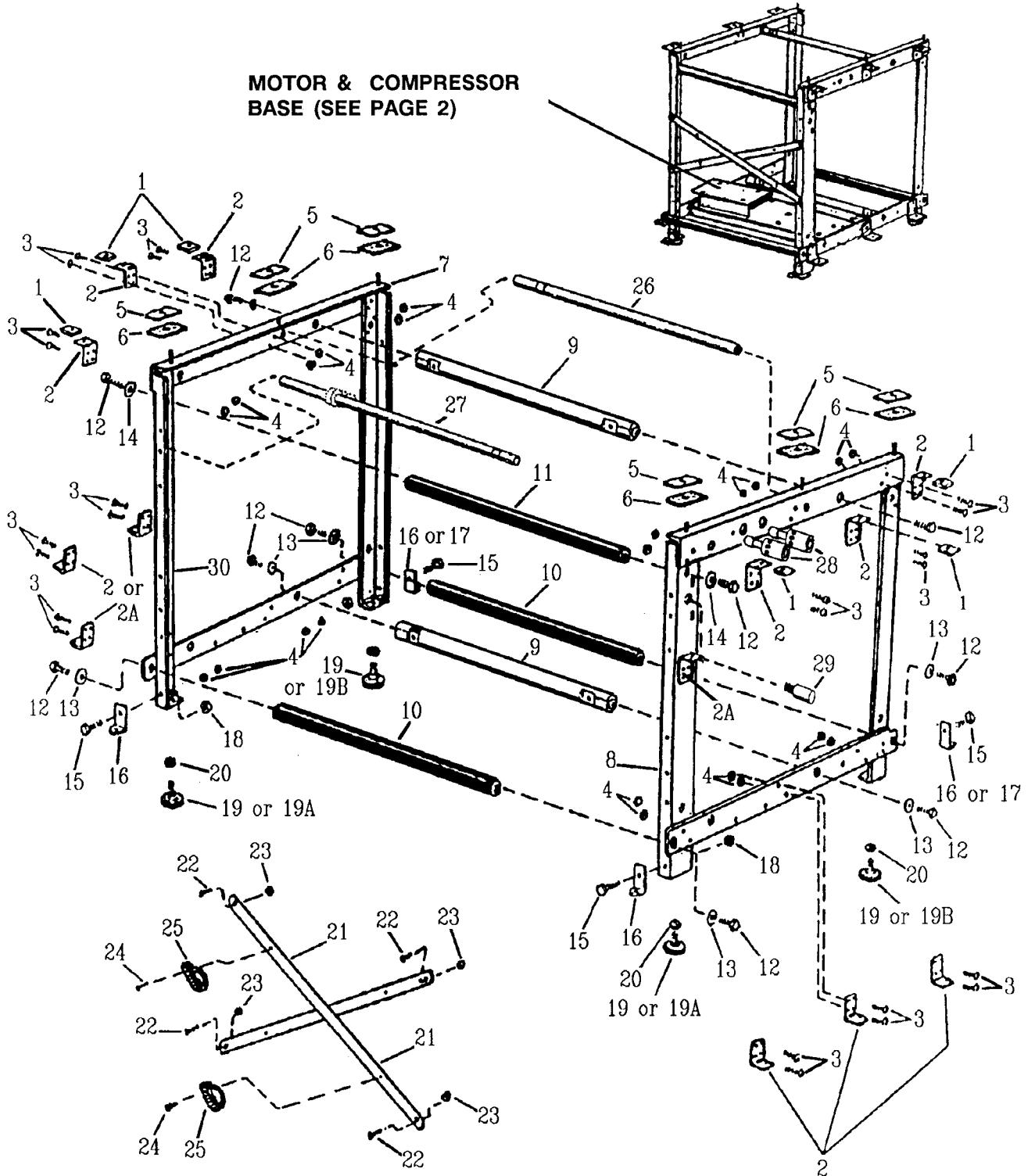



**PAGE #49**  
**BASE FRAME & BOTTOM TIE BARS**

KEY #	PART#	DESCRIPTION
1	P-1101	<u>SPEED NUT</u> - FOR COVERS, ITEMS #13 & #22, PAGE 47 FOR 350 & 360.
	P-530	<u>SPEED NUT</u> - FOR COVERS, ITEMS #13 & #22, PAGE 47 FOR 375 & ITEMS #8 & #9, PAGE 47A FOR 9800.
2	P-36932	<u>BRACKET</u>
2A	P-98932	<u>BRACKET</u> - COVER MOUNTING.
3	P-542	<u>SCREW</u> - (SLOTTED - USE WITH P-472)
	P-266	<u>SCREW</u> - (PHILLIPS - USE WITH P-469)
	P-943	<u>HEX SCREW</u> - FOR 9800.
4	P-472	<u>NUT</u> - (FLANGED LOCKING - USE WITH P-542)
	P-469	<u>NUT</u> - (STANDARD - USE WITH P-266)
5	P-36917	<u>SUPPORT PLATE</u>
6	P-36243	<u>SUPPORT PAD</u> - FELT
7	P-36916	<u>BASE FRAME</u> - NON-OPERATORS SIDE (SAME FOR 350, 360, 360 PRO, AND 369 NEW AND OLD STYLE)
8	P-36913	<u>BASE FRAME</u> - OPERATORS SIDE (SAME FOR 350, 360, 360 PRO, AND 369 NEW AND OLD STYLE)
9	P-36887	<u>TIE BAR</u> - NEEDED ALSO FOR FRONT PANEL ATTACHMENT, SEE ITEM #24, PAGE 7.
	P-37887	<u>TIE BAR</u> - NEEDED ALSO FOR FRONT PANEL ATTACHMENT, SEE ITEM #24, PAGE 7.
10	P-36880	<u>TIE BAR</u>
	P-37880	<u>TIE BAR</u>
11	P-36879	<u>TIE BAR</u> - SUPPORT FOR ITEM 34. PAGE 4 SUPPLEMENTARY CHAIN DELIVERY CATALOG.
	P-37879	<u>TIE BAR</u> - SUPPORT FOR ITEM 34. PAGE 4 SUPPLEMENTARY CHAIN DELIVERY CATALOG.
12	P-957	<u>SCREW</u>
13	P-597	<u>WASHER</u>
14	P-601	<u>WASHER</u>
15	P-338	<u>HEX HEAD BOLT</u>
16	P-36877	<u>BRACKET</u> - USED FOR SHIPPING PURPOSES. (2 ON FRONT FOR CHAIN DELIVERY OR 2 ON FRONT AND BACK FOR CHUTE DELIVERY)
17	P-36871	<u>BRACKET</u> - USED TO MOUNT CHAIN DELIVERY (2 ON EACH PRESS)
18	P-505	<u>FLANGED LOCKNUT</u>
19	P-36867	<u>GLIDER FOOT</u> - 350, 360 & 375 ONLY. (USE WITH NUT P-500).
19A	P-98867	<u>GLIDER FOOT</u> - 9800 ONLY. BY DELIVERY SECTION. (USE WITH NUT P-506).
19B	P-98873	<u>GLIDER FOOT</u> - 9800 ONLY. BY FEEDER SECTION. (USE WITH NUT P-514).
20	P-500	<u>NUT</u> - FOR P-36867.
20A	P-506	<u>NUT</u> - FOR P-98867.
20B	P-514	<u>NUT</u> - FOR P-9873
21	P-36873	<u>SUPPORT BAR</u>
	P-37873	<u>SUPPORT BAR</u>
22	P-944	<u>SCREW</u>
23	P-487	<u>LOCKNUT</u>
24	P-973	<u>SCREW</u>
25	P-1563	<u>CABLE CLAMP</u> - HAS SPEED NUT ATTACHED.
26	P-36040	<u>MOTOR MOUNT SHAFT</u> - SEE ITEM #3, PAGE 1.
	P-37040	<u>MOTOR MOUNT SHAFT</u> - SEE ITEM #3, PAGE 1.
27	P-36036	<u>SHAFT ASSEMBLY</u> - FOR MOTOR SPEED ADJUSTMENT PIVOT, SEE ITEM #16, PAGE 1.
	P-37036	<u>SHAFT ASSEMBLY</u> - FOR MOTOR SPEED ADJUSTMENT PIVOT, SEE ITEM #16, PAGE 1.
28	P-36074	<u>BLEEDER VALVE</u> - 350, 360 & 375 (SEE ITEM #26, PAGE 4)
	P-36847	<u>BLEEDER VALVE</u> - 369 & 9800 (SEE ITEM #1, PAGE 4A)
29	P-36044	<u>STUD</u> - MOTOR CONTROL STOP.
	P-36045	<u>STUD</u> - MOTOR CONTROL STOP (240V-50HZ)
30	P-98913	<u>BASE FRAME</u> - COMPLETE FOR 9800.

**DRAWING #50**  
**LAMP, WASH-UP BOTTLE, GAUGES & SUPPLIES**

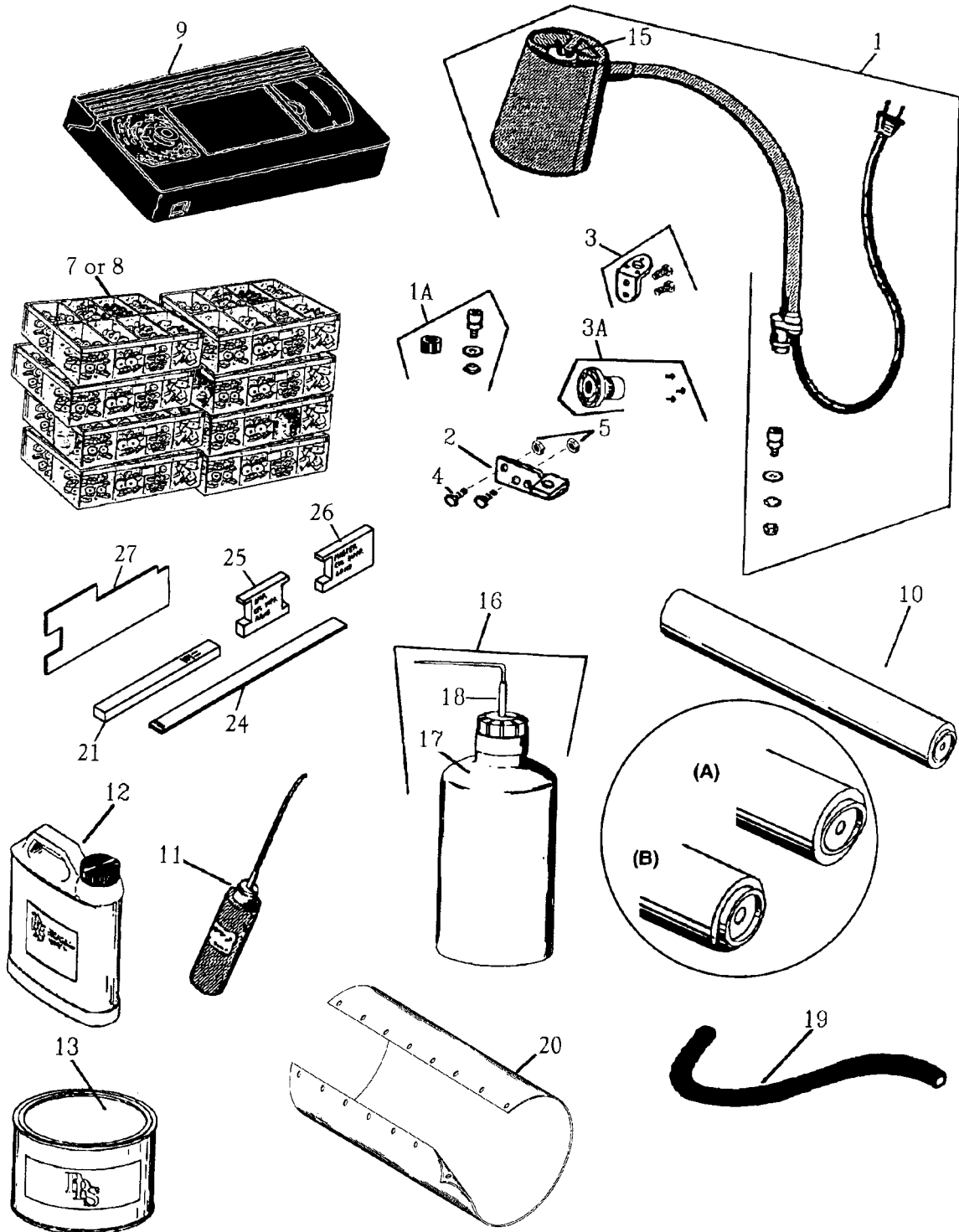

**PAGE #50**  
**LAMP, WASH-UP BOTTLE, GAUGES & SUPPLIES**

KEY #	PART#	DESCRIPTION
1	P-1956	<u>LAMP ASSEMBLY</u> - INCLUDES P-1950 MOUNTING KIT, STUD, WASHER, SHOULDER NUT, NYLOC NUT & PLUG. PLUGS INTO ITEM #25 PAGE 48A.
1A	P-1950	<u>MOUNTING KIT</u> - COMES WITH PIVOT STUD, WASHER, LOCKING NUT & CORD STRAIN RELIEF.
2	P-1954	<u>BRACKET</u> - MOUNTS TO LOWER SIDE FRAME. <i>SEE NOTE</i> .
3	P-1952	<u>UNIVERSAL BRACKET KIT</u> - HOLES MUST BE DRILLED FOR MOUNTING. COMES COMPLETE WITH SELF TAPPING SCREWS.
3A	P-1953	<u>HORIZONTAL MOUNTING BRACKET KIT</u> - COMES COMPLETE WITH TAPPING SCREWS.
4	P-944	<u>HEX HEAD SCREW</u> - FOR MOUNTING BRACKET ITEM #2 THIS PAGE.
5	P-487	<u>NUT</u> - FOR 3/8" HOLE IN YOUR BRACKET.
7	P-1707	<u>SMALL MASTER KIT</u> - INCLUDES THE MOST COMMONLY USED NUTS, WASHERS, SCREWS, RINGS, PINS & SPRINGS, ... (720 PCS.). INCLUDES P-1701, P-1702, P-1704, P-1705 & P-1706.
	P-1712	<u>LARGE MASTER KIT</u> - INCLUDES THE MOST COMMONLY USED NUTS, WASHERS, SCREWS, RINGS, PINS & SPRINGS, ... (2288 PCS.). INCLUDES P-1701, P-1702, P-1708, P-1709, P-1710, P-1711.
8	P-1701	<u>SMALL NUT KIT</u> - (100 PCS.)
	P-1702	<u>SMALL WASHER KIT</u> - (120 PCS.)
	P-1703	<u>SMALL SCREW KIT</u> - (108 PCS.)
	P-1704	<u>SMALL RING KIT</u> - (228 PCS.)
	P-1705	<u>SMALL PIN KIT</u> - (136 PCS.)
	P-1706	<u>SMALL SPRING KIT</u> - (28 PCS.)
	P-1708	<u>LARGE SCREW KIT</u> - (386 PCS.)
	P-1709	<u>LARGE RING KIT</u> - (696 PCS.)
	P-1710	<u>LARGE TAPER &amp; ROLL PIN KIT</u> - (692 PCS.)
	P-1711	<u>LARGE SPRING KIT</u> - (290 PCS.)
9	P-1713	<u>THIS OLD PRESS</u> - THIS IS A 45 MINUTE <b>BETA</b> VIDEO TAPE, WHICH INCLUDES <u>STEP BY STEP INSTRUCTIONS</u> FOR THE MOST BASIC REPAIRS AND MAINTENANCE ON YOUR 350 OR 360 PRESSES.
	P-1714	<u>THIS OLD PRESS</u> - THIS IS A 45 MINUTE <b>VHS</b> VIDEO TAPE, WHICH INCLUDES <u>STEP BY STEP INSTRUCTIONS</u> FOR THE MOST BASIC REPAIRS AND MAINTENANCE ON YOUR 350 OR 360 PRESSES.
	P-30006	<u>THIS OLD PRESS</u> - 45 MIN. <b>VHS</b> (SPANISH) P-1713, P-1714, & P-30006 TAPES INCLUDE... REMOVING THE COVERS... TROUBLE SHOOTING THE FEED TABLE... TABLE HEIGHT ADJUSTMENT... LATCH LEVER ADJUSTMENT... THE SLIPPING CLUTCH... THE SPEED PULLEY... THE FORM ROLLERS... CYLINDER PARALLEL... FORM ROLLER END PLAY... THE WATER SYSTEM... THE IMPRESSION TRIP FINGER.
10	P-35018	<u>350 BLANKET CLEANER ROLLER</u> - OLD STYLE. THIS STYLE IS INDICATED AS (A) ON DRAWING 50.
	P-36018	<u>TOP 360 BLANKET CLEANER ROLLER</u> - THIS STYLE IS INDICATED AS (A) ON DRAWING 50.
	P-36019	<u>BOTTOM 360 BLANKET CLEANER ROLLER</u> - THIS STYLE IS INDICATED AS (B) ON DRAWING 50.
11	P-1499	<u>OILER BOTTLE</u> - (4 OZ.) USED FOR LUBRICATION OF PARTS ONLY. NOT AN ATTCHMENT.
12	P-1832	<u>OIL</u> - PROPER OIL FOR MACHINES.
13	P-1833	<u>GREASE</u> - MULTI-PURPOSE.
14	OBSOLETE	<u>DECAL CEMENT</u> - (NOT SHOWN) NOT NEEDED. DECALS ARE SELF ADHESIVE. WE HAVE FOUND THAT IT IS NOT NECESSARY TO USE DECAL CEMENT. TO APPLY YOUR DECAL, DIP IN UNIVERSAL FOUNTAIN SOLUTION FOR ONLY <u>45 TO 60 SECONDS</u> . PLACE AND WIPE WITH LITE RAG OR A DAMP SPONGE. LET STAND UNTIL ALMOST DRY THEN SLIDE OFF BACKING.
15	P-1517	<u>REPLACEMENT SOCKET</u> - FOR LAMP.
16	P-1929	<u>INK WASH-UP BOTTLE</u> - TIP DISPENSES UNIFORM STREAM AND CAN BE CUT BACK TO INCREASE FLOW.
17	P-1900	<u>BOTTLE</u>
18	P-1928	<u>STEM</u>
19	P-5331	<u>HOSE</u> - SUPPLY ITEM - I.D. 5/16" X O.D. 1/2" X O.A.L. 84". CUT TO DESIRED LENGTH FOR ANY 5/16" I.D. X 1/2" O.D. HOSE.
20	P-30052	<u>BLANKET</u> - 350 - 15-3/16" X 10" - 9 HOLES.
	P-30053	<u>BLANKET</u> - 360 - 18-1/2" X 10-5/8" - 8 HOLES.
	P-30054	<u>BLANKET</u> - 360 (3 PLY) - 18-1/2" X 5/8" - 8 HOLES.
	P-30055	<u>BLANKET</u> - 360 - 18-1/2" X 11" - 8 HOLES.
	P-30056	<u>BLANKET</u> - 375 - 18-1/2" X 12-3/4" - 10 HOLES.
	P-30057	<u>BLANKET</u> - 9840 (3 PLY) - 19-3/16" X 12-5/8" - 10 HOLES.
	P-30059	<u>BLANKET</u> - 385 - 18-3/4" X 22-5/8" - 12 HOLES.
21	P-5956	<u>GUAGE</u> - IMPRESSION CYLINDER GRIPPER FINGER. SEE PAGE 12 & 12A FOR IMPRESSION CYLINDER.
22	P-5957	<u>GUAGE</u> - .071 FEELER. NOT SHOWN. SEE PAGE 41, ITEM #25.
23	P-5958	<u>GUAGE</u> - TO LEVEL BASE FRAME ASSEMBLY. SEE PAGE 49 FOR BASE FRAME. 1/4" X 1" X 18-1/4".
24	P-5955	<u>GUAGE</u> - MASTER CYLINDER ARM ADJUSTMENT. NOT SHOWN. SEE PAGE 42 FRO MASTER CYLINDER ARMS. ALSO FOR TABLE RAISING LATCH LEVER. SEE PAGE 39 FOR TABLE RAISING LATCH.
25	P-5959	<u>GUAGE</u> - IMPRESSION CYLINDER SUPPORT ARMS.
26	P-5960	<u>GUAGE</u> - MASTER CYLINDER SUPPORT ARMS.
27	P-5962	<u>GUAGE</u> - IMPRESSION CYLINDER CAM ADJUSTMENT.

**DRAWING #51**  
**CONTROL PANEL ASSEMBLY - 9800**

**9805 & 9810**

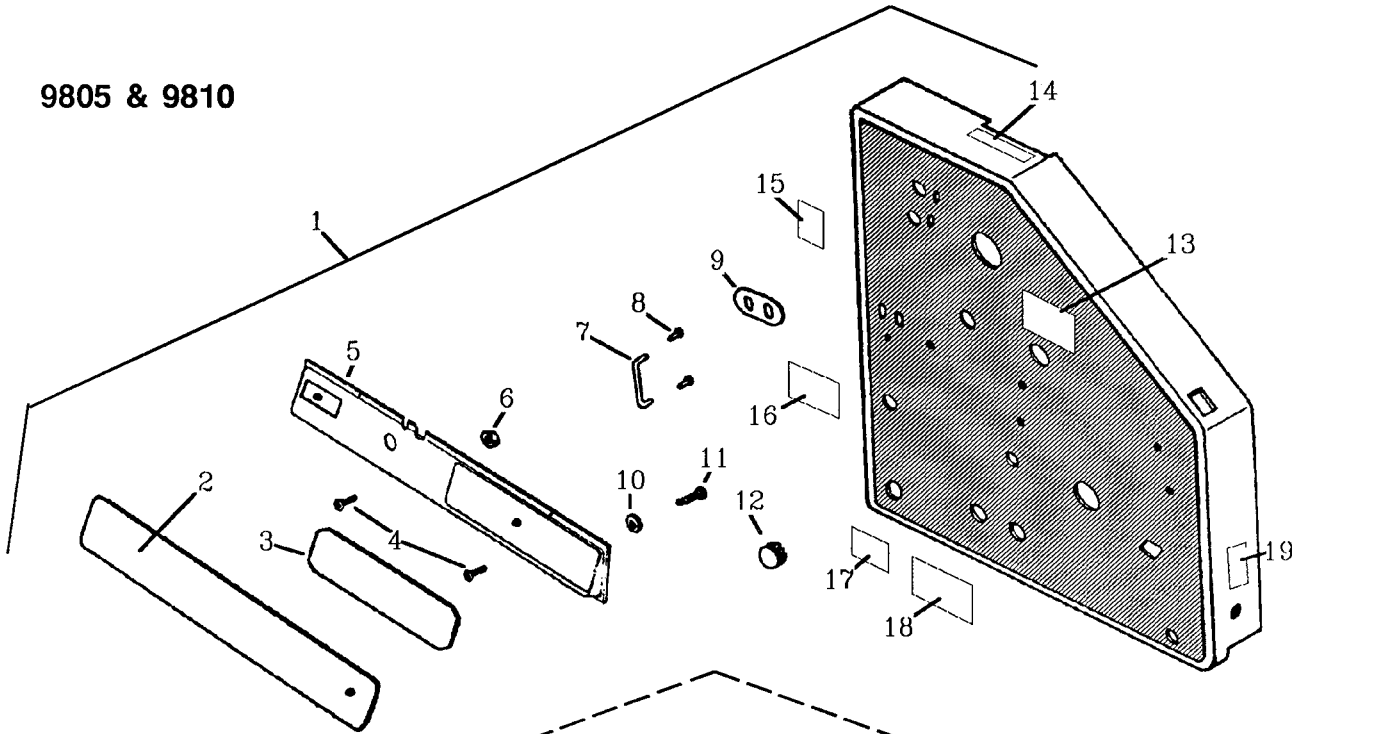

**9815 to 9850**

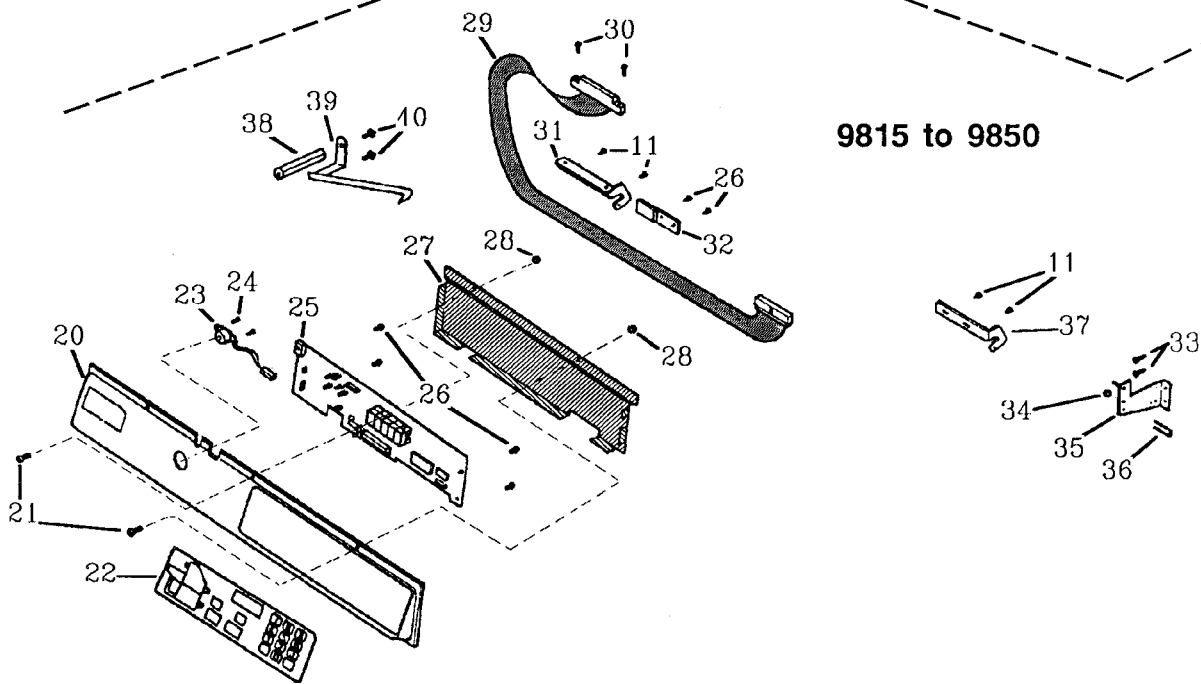

**PAGE #51**  
**CONTROL PANEL ASSEMBLY - 9800**

KEY #	PART#	DESCRIPTION
1	P-98517	<u>SIDE COVER &amp; CONTROL PANEL ASSEMBLY</u>
2	P-98551	<u>PANEL</u>
3	P-98271	<u>PLATE</u>
4	P-993	<u>SCREW</u>
5	P-98518	<u>CONTROL PANEL</u>
6	P-471	<u>NUT</u>
7	P-36904	<u>SWITCH GUARD</u> - 9805 & 9810.
8	P-204	<u>SCREW</u>
9	P-98902	<u>SWITCH PLATE</u> - 9805 & 9810.
10	P-567	<u>WASHER</u>
11	P-1474	<u>SCREW</u>
12	P-1744	<u>PLUG</u>
13	P-36900	<u>DECAL</u> - OPERATION CONTROL LEVER.
14	P-98894	<u>DECAL</u> - WATER CONTROL.
15	P-98898	<u>DECAL</u> - FORM ROLLERS.
16	P-98046	<u>DECAL</u> - SPEED CONTROL.
17	P-36896	<u>DECAL</u> - BUCKLE ADJUSTMENT.
18	P-36960	<u>DECAL</u> - AIR & VACUUM.
19	P-98922	<u>DECAL</u> - PAPER HEIGHT ADJUSTMENT.
20	P-98518	<u>CONTROL PANEL</u>
21	P-993	<u>SCREW</u>
22	P-98519	<u>SWITCH PANEL OVERLAY</u> - TD & CD.
	P-98540	<u>SWITCH PANEL OVERLAY</u> - QP, QPC & PRO.
	P-98562	<u>SWITCH PANEL OVERLAY</u> - 9870.
23	P-4035	<u>BUZZER ASSEMBLY</u> - SCREWS ONTO CONTROL PANEL ITEM #20, THIS PAGE.
24	P-5375	<u>SCREW</u>
25	P-98829	<u>P.C. KEYBOARD</u> - TD & CD.
	P-98566	<u>P.C. KEYBOARD</u> - QP, QPC & PRO.
26	P-242	<u>SCREW</u> - MOUNTS ITEM #25, TO ITEM #20, THIS PAGE.
27	P-98971	<u>COVER</u>
28	P-471	<u>NUT</u>
29	P-98546	<u>CABLE ASSEMBLY</u>
30	P-232	<u>SCREW</u>
31	P-98968	<u>CABLE BRACKET</u> - HINGE.
32	P-98999	<u>PLATE</u>
33	P-259	<u>SCREW</u>
34	P-456	<u>NUT</u>
35	P-98673	<u>BRACKET</u>
36	P-3011	<u>PIN</u> - FOR CABLE ITEM #29, THIS PAGE.
37	P-98751	<u>BRACKET</u> - HINGE.
38	P-7018	<u>STUD</u>
39	P-98373	<u>CABLE BRACE</u>
40	P-81	<u>SCREW</u>

**DRAWING #52**  
**CLOCK SYNCHRONIZER ASSEMBLY MECHANISM - 9800**

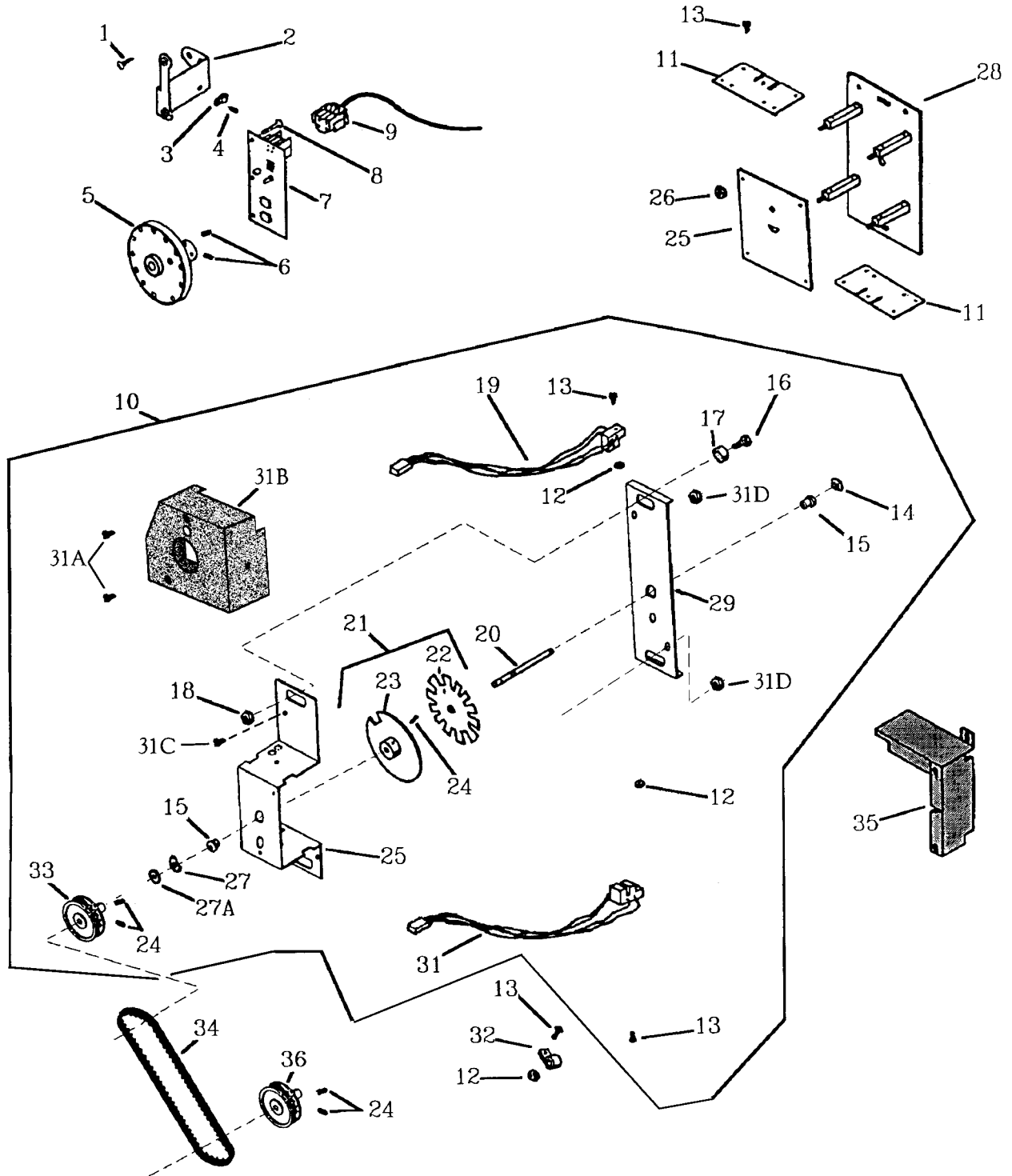

**PAGE #52**  
**CLOCK SYNCHRONIZER ASSEMBLY MECHANISM - 9800**

KEY #	PART#	DESCRIPTION
1	P-242	<u>SCREW</u>
2	P-98862	<u>BRACKET ASSEMBLY</u>
3	P-1839	<u>CABLE ASSEMBLY</u>
4	P-967	<u>SCREW</u>
5	P-98701	<u>WHEEL ASSEMBLY</u> - HALL EFFECT MECHANISM.
6	P-11	<u>SET SCREW</u>
7	P-98886	<u>P.C.BOARD ASSEMBLY</u>
8	P-235	<u>SCREW</u>
9	P-4048	<u>HARNESS</u> - OLD STYLE.
	P-4049	<u>HARNESS</u> - NEW STYLE.
10	P-98007	<u>CLOCK SYNCHRONIZER ASSEMBLY MECHANISM</u> - NEW STYLE AVAILABLE AS ASSEMBLY ONLY. DOES NOT CONTAIN ITEMS #11, #16, #17 & #18 - P-487. CONSISTS OF ITEMS #12 - #24, #33.
11	P-98008	<u>SENSOR MOUNTING PLATE</u> - OLD STYLE. NOT PART OF P-98007.
12	P-456	<u>NUT</u>
13	P-230	<u>SCREW</u>
14	P-669	<u>C-RING</u>
15	P-5803	<u>BUSHING</u>
16	P-945	<u>SCREW</u> - NOT PART OF P-98007.
17	P-1749	<u>SPACER</u> - FOR OLD STYLE. NOT PART OF P-98007.
18	P-471	<u>NUT</u> - FOR NEW STYLE. NOT PART OF P-98007.
	P-487	<u>NUT</u> - FOR OLD STYLE. NOT PART OF P-98007.
19	P-4032	<u>SENSOR CABLE ASSEMBLY</u> - MOUNTS INSIDE NEW STYLE BRACKET ITEM #25, THIS PAGE.
20	P-98283	<u>SHAFT</u> - OLD STYLE.
	P-98267	<u>SHAFT</u> - NEW STYLE.
21	P-98301	<u>WHEEL ASSEMBLY</u> - NEW STYLE. ITEMS #22 & #23 ARE NOT AVAILABLE SEPARATELY FOR NEW STYLE.
22	P-98303	<u>WHEEL</u> - OLD STYLE.
23	P-98305	<u>WHEEL</u> - OLD STYLE.
24	P-5	<u>SET SCREW</u>
25	P-98361	<u>COVER PLATE</u> - OLD STYLE. NOT PART OF ASSEMBLY P-98007.
	P-98280	<u>COVER PLATE</u> - NEW STYLE.
27	P-1815	<u>LOCK WASHER</u>
27A	P-5502	<u>WASHER</u>
28	P-98124	<u>BASE PLATE</u> - OLD STYLE. NOT PART OF P-98007.
29	P-98126	<u>BASE PLATE</u> - NEW STYLE.
30	P-641	<u>WASHER</u>
31	P-4047	<u>SENSOR CABLE ASSEMBLY</u> - MOUNTS INSIDE NEW STYLE BRACKET ITEM #25, THIS PAGE.
31A	P-10345	<u>TAPPING SCREW</u>
31B	P-98304	<u>PLASTIC COVER</u> - NEW STYLE.
31C	P-246	<u>SCREW</u>
31D	P-462	<u>KEPS NUT</u>
32	P-1838	<u>CABLE CLAMP</u>
33	P-1742	<u>PULLEY</u>
34	P-1661	<u>TIMING BELT</u>
35	P-98302	<u>PLASTIC COVER</u> - OLD STYLE.
36	P-1742	<u>PULLEY</u> - CONNECTS TO ITEM #18, PAGE 44.

**DRAWING #53**  
**MAIN SPROCKET ASSEMBLY, STAR BARS, STAR WHEELS**  
**& STAR WHEEL CLEANER ROLLER**

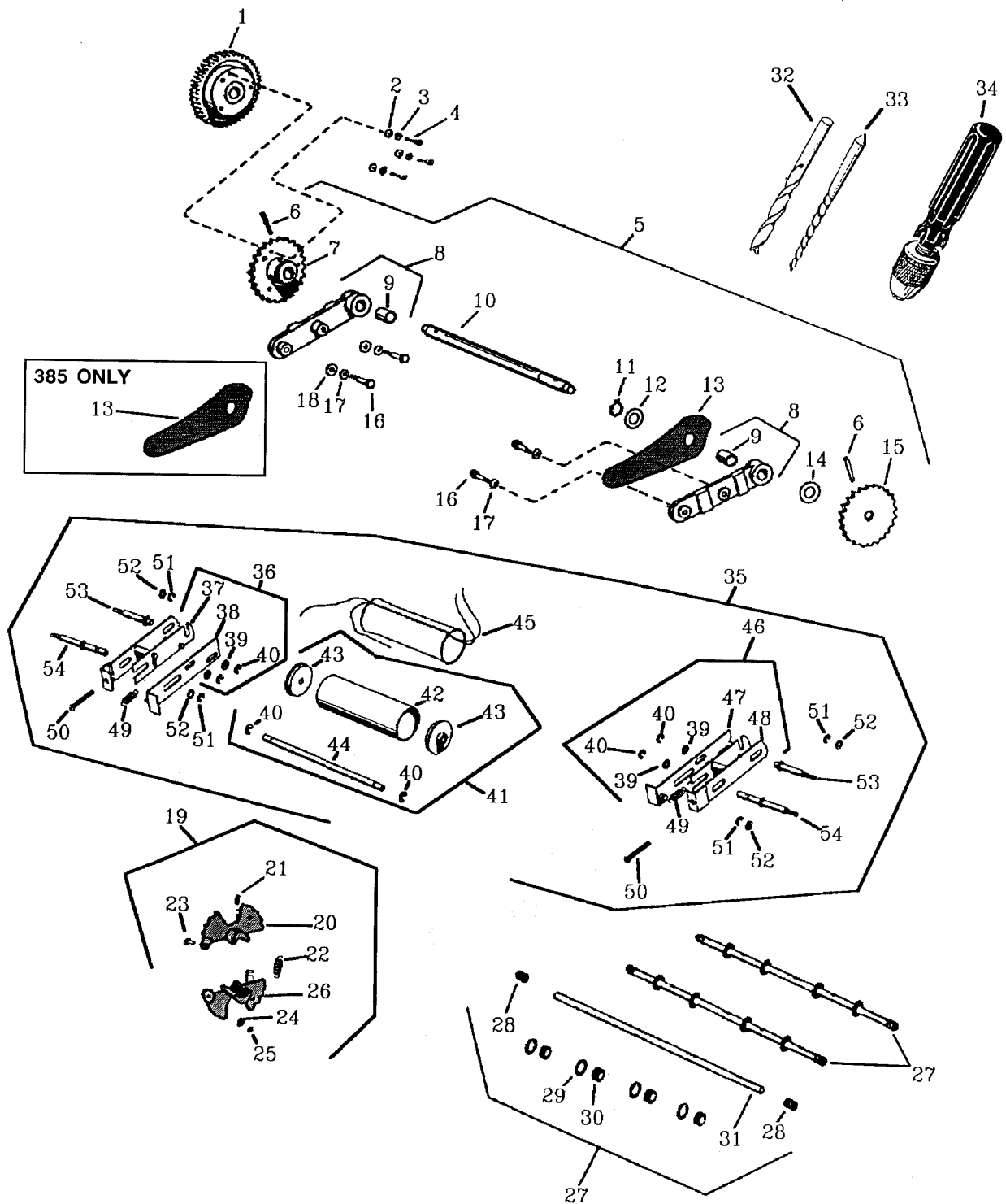



## MAIN SPROCKET ASSEMBLY, STAR BARS, STAR WHEELS &amp; STAR WHEEL CLEANER ROLLER

KEY #	PART#	DESCRIPTION
1	P-361140	<u>CHAIN DRIVE GEAR</u> - HAS 1/4" HUB. DRIVEN BY IMPRESSION CYLINDER GEAR ITEM #10 PAGE 12.
	P-362560	<u>CHAIN DRIVE GEAR</u> - 360 O.S. & 385. HAS 3/8" HUB. DRIVEN BY IMPRESSION CYLINDER GEAR ITEM #10 PAGE 12.
2	P-590	<u>WASHER</u>
3	P-627	<u>LOCKWASHER</u>
4	P-55	<u>SCREW</u>
5	P-361160	<u>MAIN SHAFT &amp; SPROCKET ASSEMBLY</u> - 350 & 360.
	P-371160	<u>MAIN SHAFT &amp; SPROCKET ASSEMBLY</u> - 375 & 9800.
	P-381160	<u>MAIN SHAFT &amp; SPROCKET ASSEMBLY</u> - 385.
6	P-453	<u>TAPER PIN</u>
7	P-361180	<u>SPROCKET - N.O.S.</u> - DRIVES ITEM #19 PAGE 54. PILOT HOLE ONLY, MUST HAVE PROPER TOOLS TO INSTALL. NEED DRILL BIT P-1505, REAMER BIT P-1559 & HAND REAMER TOOL P-1546.
8	P-361200	<u>SUPPORT ARM ASSEMBLY</u> - ATTACHES TO CHAIN DELIVERY SIDE FRAME. SEE ITEM #8 DRAWING 61.
9	P-1271	<u>BUSHING</u>
10	P-361220	<u>SHAFT</u> - 350 & 360. SHAFT IS NOT PRE-DRILLED FOR SPROCKETS IF PURCHASED SEPARATELY. HOLES MUST BE DRILLED TO ACCOMODATE SPROCKETS FOR PRECISE ALIGNMENT. NEED DRILL BIT P-1505 & REAMER P-1559.
	P-371220	<u>SHAFT</u> - 375 & 9800. SHAFT IS NOT PRE-DRILLED FOR SPROCKETS IF PURCHASED SEPARATELY. HOLES MUST BE DRILLED TO ACCOMODATE SPROCKETS FOR PRECISE ALIGNMENT. NEED DRILL BIT P-1505 & REAMER P-1559.
	NO#.	<u>SHAFT</u> - 385. SHAFT IS NOT PRE-DRILLED FOR SPROCKETS IF PURCHASED SEPARATELY. HOLES MUST BE DRILLED TO ACCOMODATE SPROCKETS FOR PRECISE ALIGNMENT. NEED DRILL BIT P-1505 & REAMER P-1559.
11	P-709	<u>RETAINING RING</u>
12	P-1048	<u>WASHER</u>
13	P-361240	<u>GRIPPER OPERATING CAM</u> - FOR 350, 360, 375 & 9800 TO 9870 <i>USE 1 ONLY. FOR 385 &amp; 9880 USE 2.</i>
14	P-1051	<u>WASHER</u>
15	P-361260	<u>SPROCKET - O.S.</u> - DRIVES ITEM #19 PAGE 54. PILOT HOLE ONLY MUST HAVE PROPER TOOLS TO INSTALL. NEED DRILL BIT P-1505 & REAMER P-1559.
16	P-8031	<u>SHOULDER SCREW</u>
17	P-629	<u>LOCKWASHER</u>
18	P-361300	<u>SPACER</u>
19	P-361320	<u>STAR WHEEL ASSEMBLY</u> - ATTACHES TO SHAFT ITEM #10 THIS PAGE.
20	P-361340	<u>STAR WHEEL SEGMENT</u>
21	P-10632	<u>PIN</u>
22	P-36177	<u>SPRING</u>
23	P-9042	<u>PIN</u>
24	P-654	<u>WASHER</u>
25	P-668	<u>C-RING</u>
26	P-361380	<u>STAR WHEEL LATCH SEGMENT</u>
27	P-363010	<u>STAR BAR ASSEMBLY</u> - <i>SEE NOTE 2.</i>
	P-373010	<u>STAR BAR ASSEMBLY</u> - <i>SEE NOTE 2.</i>
	P-383010	<u>STAR BAR ASSEMBLY</u> - <i>SEE NOTE 2.</i>
28	P-363110	<u>CLIP SPRINGS</u>
29	P-640	<u>STAR WASHERS</u>
30	P-1126	<u>GROMMET</u>
31	P-363170	<u>BAR ONLY</u> - 350 & 360.
	P-373170	<u>BAR ONLY</u> - 375 & 9800.
	P-383170	<u>BAR ONLY</u> - 385.
32	P-1505	<u>DRILL BIT</u>
33	P-1559	<u>REAMER</u>
34	P-1546	<u>HAND REAMER TOOL</u>
35	P-361030	<u>STAR WHEEL CLEANER ROLLER KIT</u> - 350 & 360.
	P-371030	<u>STAR WHEEL CLEANER ROLLER KIT</u> - 375 & 9800.
36	P-361110	<u>BRACKET ASSEMBLY - N.O.S.</u>
37	P-362340	<u>BRACKET</u> - NOT SOLD SEPARATELY AT THIS TIME. MUST BUY FULL ASSEMBLY P-361110.
38	P-362330	<u>SLIDE</u> - NOT SOLD SEPARATELY AT THIS TIME. MUST BUY FULL ASSEMBLY P-361110.
39	P-583	<u>WASHER</u>
40	P-668	<u>C-RING</u>
41	P-361050	<u>ROLLER ASSEMBLY</u> - 350, 360.
	P-371050	<u>ROLLER ASSEMBLY</u> - 375, 9800.
42	P-361360	<u>ROLLER SHELL</u> - 350, 360, 375 & 9800.
43	P-361370	<u>END CAP</u> - NOT SOLD SEPARATELY AT THIS TIME. MUST BUY FULL ASSEMBLY P-361030.
44	P-361280	<u>ROLLER SHAFT</u> - 350 & 360.
	P-371280	<u>ROLLER SHAFT</u> - 375 & 9800.
45	P-362250	<u>MOLLETON COVER</u> - FOR STAR WHEEL ROLLER.
46	P-361120	<u>BRACKET ASSEMBLY - O.S.</u>
47	P-362520	<u>SLIDE</u> - NOT SOLD SEPARATELY AT THIS TIME. MUST BUY FULL ASSEMBLY P-361120.
48	P-362270	<u>BRACKET</u> - NOT SOLD SEPARATELY AT THIS TIME. MUST BUY FULL ASSEMBLY P-361120.
49	P-36549	<u>SPRING</u> - CLIPS ONTO ITEMS #38, #54, #47 & #54.
50	P-1823	<u>ADJUSTING SCREW</u> - FOR ROLLER PARALLEL ADJUSTMENT.
51	P-669	<u>C-RING</u>
52	P-595	<u>WASHER</u>
53	P-9045	<u>STUD</u> - <i>SEE NOTE 1.</i>
54	P-6039	<u>SPRING ANCHOR</u> - <i>SEE NOTE 1.</i>
		<b>NOTE 1:</b> WHEN INSTALLING STAR WHEEL CLEANER ROLLER KIT REPLACE ITEM #16 WITH ITEMS #53 & #54 STUDS.
		<b>NOTE 2:</b> STAR BARS ELIMINATE THE PROBLEM OF TRACKING USUALLY CAUSED BY STAR WHEELS. INCLUDED WITH STAR BARS ARE INSTALLATION INSTRUCTIONS.

**DRAWING #53A**  
**MAIN SPROCKET ASSEMBLY & PAPER GUIDES - 9800, 1:1**

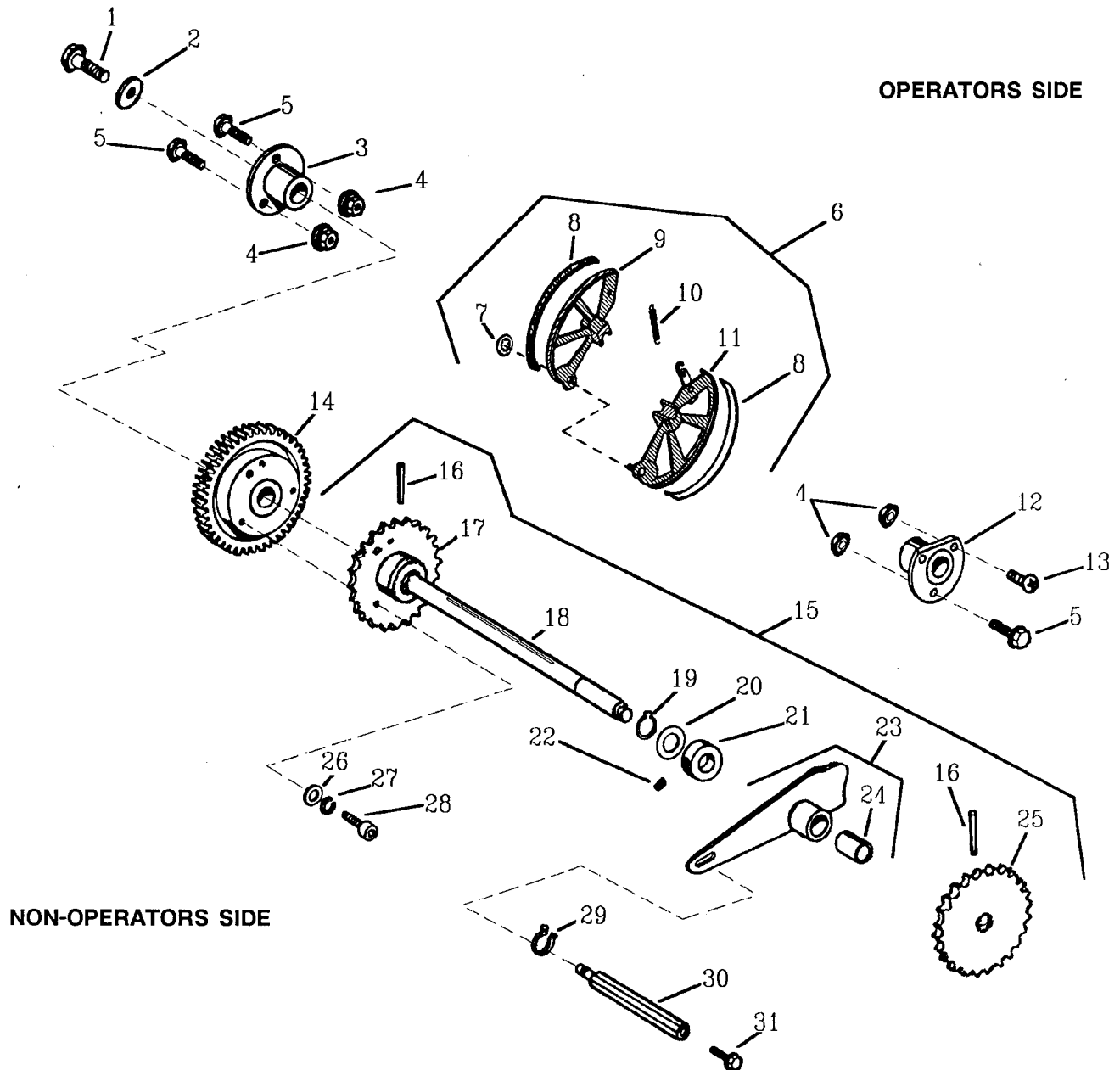

**PAGE #53A**  
**MAIN SPROCKET ASSEMBLY & PAPER GUIDES - 9800, 1-1**

KEY #	PART#	DESCRIPTION
1	P-957	<u>SCREW</u>
2	P-5335	<u>WASHER</u>
3	P-982100	<u>BEARING</u> - NON-OPERATORS SIDE.
4	P-472	<u>NUT</u>
5	P-82	<u>SCREW</u>
6	P-981320	<u>GUIDE ASSEMBLY</u> - REQUIRES 2 FOR SHAFT ASSEMBLY P-981160 ITEM #15 THIS PAGE.
7	P-5334	<u>PUSH ON WASHER</u>
8	P-983130	<u>TAPE</u>
9	P-981340	<u>GUIDE</u>
10	P-36177	<u>SPRING</u>
11	P-981380	<u>GUIDE</u>
12	P-982100	<u>BEARING</u> - OPERATORS SIDE.
	P-982360	<u>BEARING</u> - OPERATORS SIDE. FOR MACHINES WITH DOUBLE DETECTOR SWITCHES.
13	P-125	<u>SCREW</u> - FOR P-982360 ITEM #12 THIS PAGE ONLY.
14	P-982560	<u>CHAIN DRIVE GEAR</u> - DRIVEN BY IMPRESSION CYLINDER GEAR. SEE ITEM #10 PAGE 12.
15	P-981160	<u>MAIN SHAFT &amp; SPROCKET ASSEMBLY</u> - 9800, 1 TO 1 CHAIN DELIVERY.
16	P-447	<u>TAPER PIN</u>
17	P-981180	<u>SPROCKET</u> - DRIVES #19 PAGE 54.
18	P-981220	<u>SHAFT</u>
19	P-707	<u>RETAINING RING</u>
20	P-621	<u>WASHER</u>
21	P-362060	<u>COLLAR</u>
22	P-7	<u>SET SCREW</u>
23	P-981240	<u>GRIPPER OPERATING CAM</u>
24	P-1263	<u>BUSHING</u>
25	P-981260	<u>SPROCKET</u> - DRIVES ITEM #19 PAGE 54.
26	P-590	<u>WASHER</u> - NEED 3.
27	P-627	<u>LOCKWASHER</u> - NEED 3.
28	P-55	<u>CAP SCREW</u> - NEED3.
29	P-700	<u>RETAINING RING</u>
30	P-7024	<u>STUD</u>
31	P-81	<u>SCREW</u>
		<p>NOTE: ITEMS #17, 18, &amp; 25 ARE SOLD SEPARATELY FOR FIELD REPLACEMENT. HOWEVER, THESE PARTS ARE ASSEMBLED IN A FIXTURE AT OUR FACTORY TO INSURE PROPER TIMING AND ALIGNMENT OF BOTH SPROCKETS AND SHAFT. WE STRONGLY RECOMMENDED THAT YOU BUY THE COMPLETE ASSEMBLY P-981160 ITEM #15.</p>

**DRAWING #54**  
**DRIVE CHAIN, GRIPPER BARS & CHAIN SUPPORTS**

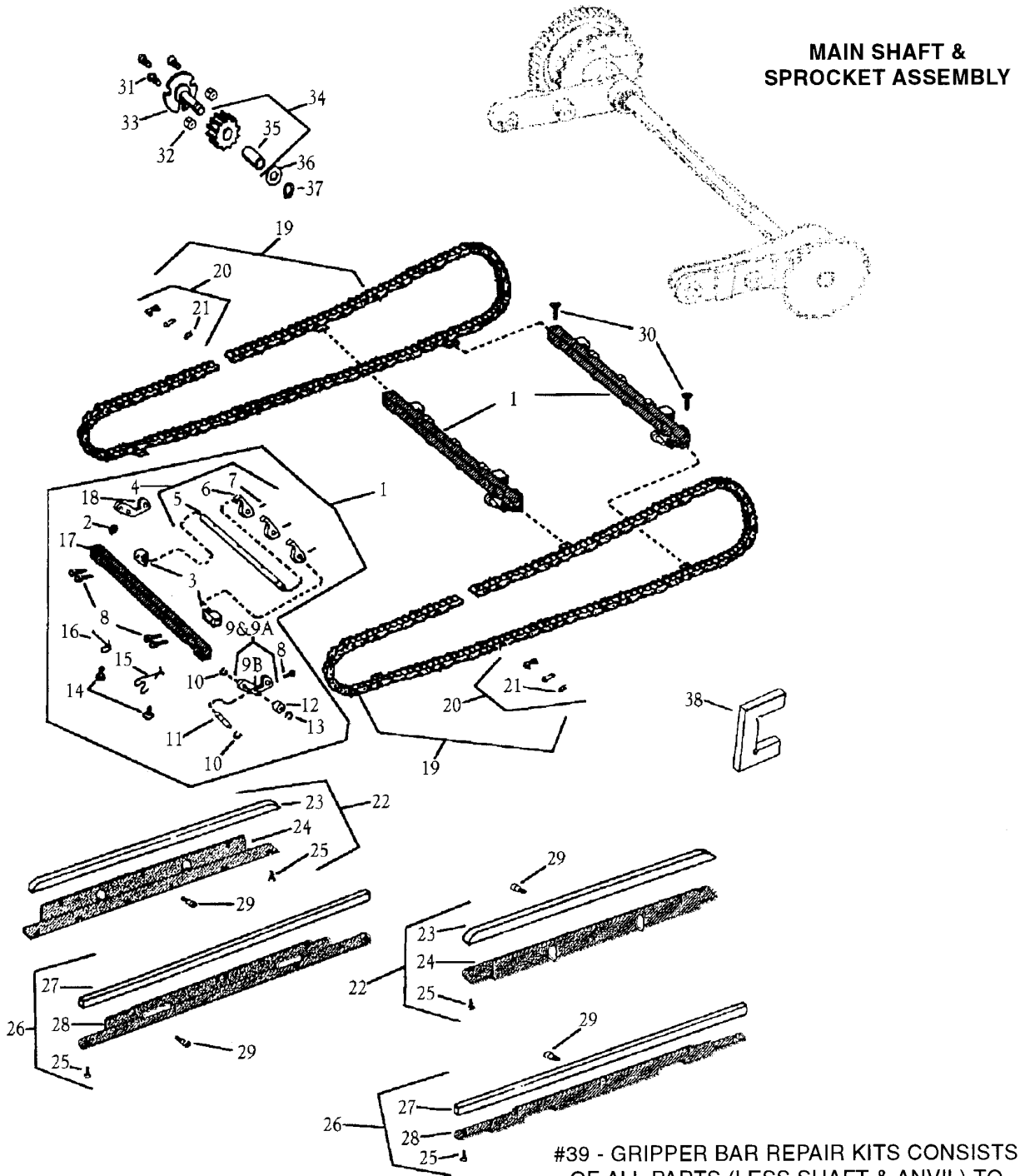

#39 - GRIPPER BAR REPAIR KITS CONSISTS OF ALL PARTS (LESS SHAFT & ANVIL) TO REPAIR YOUR GRIPPER BAR. (NEED 1 KIT PER GRIPPER BAR)

**PAGE #54**  
**DRIVE CHAIN, GRIPPER BARS & CHAIN SUPPORTS**

KEY #	PART#	DESCRIPTION
1	P-360990	<u>GRIPPER BAR ASSEMBLY</u> - 350 & 360.
	P-370990	<u>GRIPPER BAR ASSEMBLY</u> - 375 & 9800 STANDARD. 9800 STANDARD CAN BE DEFINED BY 4-3/8" DRIVE SPROCKETS.
	P-980990	<u>GRIPPER BAR ASSEMBLY</u> - 9800 1 TO 1 CHAIN DELIVERY. 9800 1-1 CD CAN BE IDENTIFIED BY 6-1/2" DRIVE SPROCKETS
	P-380990	<u>GRIPPER BAR ASSEMBLY</u> - 385.
2	P-700	<u>RING</u>
3	P-361000	<u>BEARING</u> - USE 2 FOR 350, 360 & 375. USE 3 FOR 385.
4	P-361010	<u>GRIPPER SHAFT ASSEMBLY</u> - 350 & 360.
	P-371010	<u>GRIPPER SHAFT ASSEMBLY</u> - 375 & 9800.
	P-381010	<u>GRIPPER SHAFT ASSEMBLY</u> - 385.
5	P-361060	<u>SHAFT</u> - 350 & 360.
	P-371060	<u>SHAFT</u> - 375 & 9800.
	P-381060	<u>SHAFT</u> - 385
6	P-361020	<u>GRIPPER FINGER</u> - USE 3 FOR 350 & 360. USE 4 FOR 375 & 9800. USE 8 FOR 385.
7	P-3001	<u>PIN</u>
8	P-37	<u>SCREW</u>
9	P-361039	<u>CAM LEVER &amp; ROLLER ASSEMBLY - COMPLETE</u> - 350, 360, 375, 9800 Standard, 385, 9880.
9	P-981039	<u>CAM LEVER &amp; ROLLER ASSEMBLY - COMPLETE</u> - 9800 1 to 1, 9890.
9A	P-361040	<u>CAM LEVER ASSEMBLY</u> - 350, 360, 375, 9800 STANDARD & 385 OPERATORS SIDE ONLY. SEE ITEM #18 FOR 385 NON-OPERATORS SIDE ARM. (NOT SOLD WITHOUT PIN).
9A	P-981040	<u>CAM LEVER ASSEMBLY</u> - 9800 1 TO 1 CHAIN DELIVERY. (NOT SOLD WITHOUT PIN).
9B	P-9043	<u>STUD</u> - 350, 360, 375, 9800 STANDARD & 385.
9B	P-9052	<u>STUD</u> - 9800 1 TO 1 CHAIN DELIVERY.
10	P-666	* <u>RING</u> - FOR OLD STYLE PIN ONLY. NOW USING ROLL PIN. - ALL MODELS. (NOT PART OF LEVER ASSEMBLY).
11	P-401	<u>ROLL PIN</u> - REPLACES OLD STYLE PIN W/RET. RINGS.
12	P-1416	<u>CAM</u> - 350, 360, 375, 9800 STANDARD & 385. (1/4" WIDE) OPERATED BY ITEM 22 PAGE 55 & ITEM 13 PAGE 53.
	P-1415	<u>CAM</u> - 9800 1 TO 1 CHAIN DELIVERY. (3/8" WIDE) OPERATED BY ITEM 22 PAGE 55 & ITEM 13 PAGE 53
13	P-668	<u>RING</u>
14	P-8032	<u>SHOULDER SCREW</u>
15	P-361070	<u>BUTTERFLY SPRING</u> - 350 & 360 - 1 ONLY PER ASSEMBLY ALONG WITH 1 P-361080.
	P-371070	<u>BUTTERFLY SPRING</u> - 375 & 9800 - 2 PER ASSEMBLY.
	P-381070	<u>BUTTERFLY SPRING</u> - 385 - 4 PER ASSEMBLY.
16	P-361080	<u>LOOP SPRING</u> - 350 & 360 - 1 ONLY PER ASSEMBLY ALONG WITH 1 P-361070.
17	P-361090	<u>GRIPPER BAR ANVIL</u> - 350 & 360.
	P-371090	<u>GRIPPER BAR ANVIL</u> - 375 & 9800.
	P-381090	<u>GRIPPER BAR ANVIL</u> - 385, 9880, 9890.
18	P-381040	<u>CAM LEVER ASSEMBLY</u> - 385 NON-OPERATORS SIDE. SEE ITEM #9 FOR 385 OPERATORS SIDE ARM. (NOT SOLD WITHOUT PIN).
18	P-9881040	<u>CAM LEVER ASSEMBLY</u> - 9890 NON-OPERATORS SIDE. SEE ITEM #9 FOR 9890 OPERATORS SIDE ARM. (NOT SOLD WITHOUT PIN).
19	P-361100	<u>CHAIN</u> - OLD STYLE. HAS 1/2" CARRIER LINKS. DRIVEN BY ITEM #7 & #5 PAGE 53 & #19 PAGE 55. CHAINS CANNOT BE PURCHASED SEPARATELY. MUST BUY IN SETS OF 2.
	P-361390	<u>CHAIN</u> - NEW STYLE. HAS 5/8" CARRIER LINKS. DRIVEN BY ITEM #7 & #5 PAGE 53 & #19 PAGE 55. CHAINS CANNOT BE PURCHASED SEPARATELY. MUST BUY IN SETS OF 2.
	P-981390	<u>CHAIN</u> - 9800 1 TO 1 CHAIN DELIVERY. HAS 1/2" CARRIER LINKS. DRIVEN BY ITEM #7 & #5 PAGE 53 & #19 PAGE 55. CHAINS CANNOT BE PURCHASED SEPARATELY. MUST BUY IN SETS OF 2.
20	P-1395	<u>CONNECTING LINK</u> - 350, 360, 375, 385, 9800 Standard.
	P-4328	<u>CONNECTING LINK</u> - 9800 1-1.
21	P-1394	<u>LINK CLIP</u>
22	P-361150	<u>UPPER SUPPORT ASSEMBLY</u> - OLD STYLE. MUST BE USED WITH PART P-361100. MOUNTS TO INSIDE OF SIDE FRAME L.H. & R.H. SIDE. SEE ITEM #9 DRAWING 61.
	P-361170	<u>UPPER SUPPORT ASSEMBLY</u> - NEW STYLE. MUST BE USED WITH PART P-361390. MOUNTS TO INSIDE OF SIDE FRAME L.H. & R.H. SIDE. SEE ITEM #9 DRAWING 61.
23	P-361190	<u>UPPER CHAIN TRACK</u> - ITEM #19 THIS PAGE RIDES ON THIS TRACK.
24	P-361210	<u>UPPER SUPPORT</u> - OLD STYLE. MUST BE USED WITH PART P-361100.
	P-361230	<u>UPPER SUPPORT</u> - NEW STYLE. MUST BE USED WITH PART P-361390.
25	P-975	<u>SCREW</u>
26	P-361250	<u>LOWER SUPPORT ASSEMBLY</u> - OLD STYLE. MUST BE USED WITH PART P-361100. MOUNTS TO INSIDE OF SIDE FRAME L.H. & R.H. SIDE. SEE ITEM #6 DRAWING 61.
	P-361270	<u>LOWER SUPPORT ASSEMBLY</u> - NEW STYLE. MUST BE USED WITH PART P-361390. MOUNTS TO INSIDE OF SIDE FRAME L.H. & R.H. SIDE. SEE ITEM #6 DRAWING 61.
27	P-361290	<u>LOWER TRACK</u> - OLD STYLE. MUST BE USED WITH PART P-361100. ITEM #19 THIS PAGE RIDES ON THIS TRACK.
	P-361310	<u>LOWER TRACK</u> - NEW STYLE. MUST BE USED WITH PART P-361390. ITEM #19 THIS PAGE RIDES ON THIS TRACK.
28	P-361330	<u>LOWER SUPPORT</u> - OLD STYLE. MUST BE USED WITH PART P-361100.
	P-361350	<u>LOWER SUPPORT</u> - NEW STYLE. MUST BE USED WITH PART P-361390.
29	P-8033	<u>SHOULDER SCREW</u>
30	P-125	<u>SCREW</u>
31	P-263	<u>SCREW</u>
32	P-471	<u>NUT</u>
33	P-36539	<u>BEARING STUD N.S.</u> - MOUNTS INTO SIDE FRAME. SEE ITEM #41 PAGE 46. MUST USE NEW GEAR P-36661.
34	P-36661	<u>GEAR</u> - NEW STYLE. HAS ONE HUB ON EACH SIDE. RIDES ON GEAR FOR MAIN SHAFT & SPROCKET ASSEMBLY.
	P-36534	<u>GEAR</u> - OLD STYLE. HAS HUB ON ONE SIDE ONLY. RIDES ON GEAR FOR MAIN SHAFT & SPROCKET ASSEMBLY.
	P-98661	<u>GEAR</u> - 8800CD, 9800 CD.
35	P-827	<u>BUSHING</u>
36	P-604	<u>WASHER</u>
37	P-703	<u>RETAINING RING</u>
38	P-5026	<u>GUAGE</u> - FOR GRIPPER ARM ADJUSTMENT.
39	P-30730	<u>GRIPPER BAR REPAIR KIT</u> - 350, 360.
	P-30731	<u>GRIPPER BAR REPAIR KIT</u> - 375, 9800 STD., 9800, 1-1.
	P-30732	<u>GRIPPER BAR REPAIR KIT</u> - 385.

**DRAWING #55**  
**CHAIN GUIDE IDLER SHAFT ASSEMBLY - (REAR) 350, 360, 375, 385**

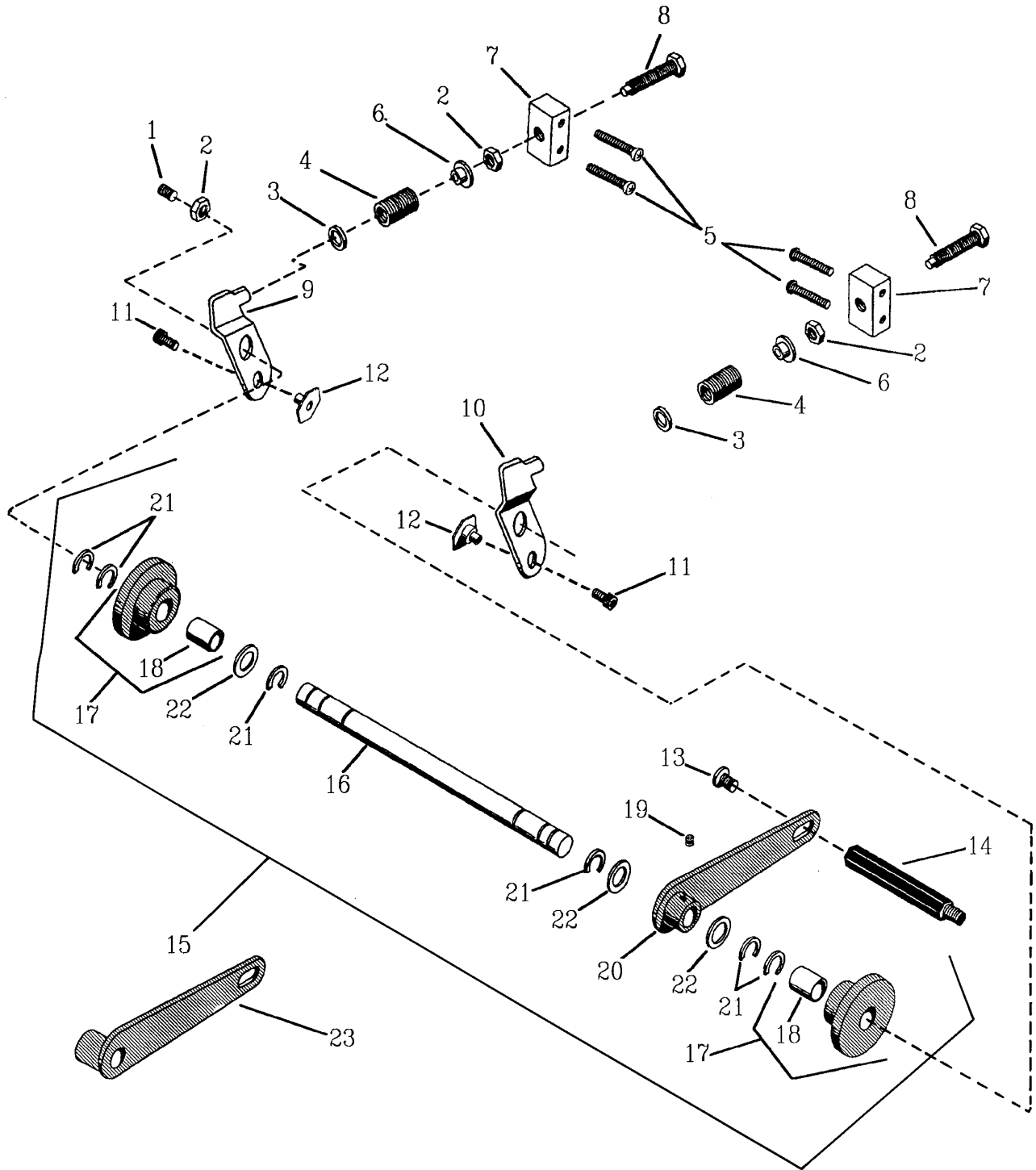

**PAGE #55**  
**CHAIN GUIDE IDLER SHAFT ASSEMBLY - (REAR) 350, 360, 375, 385**

KEY #	PART#	DESCRIPTION
1	P-33	<u>SET SCREW</u> - FOR SHAFT ADJUSTMENT. DOES NOT SCREW INTO SHAFT. SCREWS IN THROUGH SIDE FRAME. SEE ITEM #2, DWG. 61.
2	P-492	<u>NUT</u>
3	P-361400	<u>SPACER</u>
4	P-361420	<u>SPRING</u>
5	P-1389	<u>SCREW</u>
6	P-361440	<u>SPRING RETAINER</u>
7	P-361460	<u>ADJUSTING BLOCK</u> - (ATTACHES TO SIDE FRAME, SEE ITEM #1, DWG. 61)
8	P-954	<u>ADJUSTING SCREW</u>
9	P-361480	<u>GUIDE TENSION LEVER</u> - NON-OPERATOR S SIDE. ATTACHES ONTO SHAFT, ITEM #16, THIS PAGE.
10	P-361500	<u>GUIDE TENSION LEVER</u> - OPERATORS SIDE. ATTACHES ONTO SHAFT. ITEM #16, THIS PAGE.
11	P-43	<u>SCREW</u> - FOR NEW STYLE NUT P-361520, THIS PAGE. SCREWS IN FROM OUTSIDE SIDE FRAME, SEE ITEM #4, DWG. 61.
	P-77	<u>SCREW</u> - FOR OLD STYLE NUT P-361130, ITEM #11, THIS PAGE.
12	P-361520	<u>NUT</u> - NEW STYLE, HAS 1/16" THICK FLANGE. FITS IN THROUGH SIDE FRAME. SEE ITEM #5, DWG. 61.
	P-361130	<u>NUT</u> - OLD STYLE, HAS 1/8" THICK FLANGE. FITS IN THROUGH SIDE FRAME. SEE ITEM #5, DWG. 61.
13	P-8034	<u>SHOULDER SCREW</u> - NEW STYLE, HAS 3/8" HUB.
14	P-7007	<u>STUD</u> - FOR MOUNTING LOCATION SEE ITEM #14, DWG. 61.
15	P-361580	<u>IDLER SHAFT ASSEMBLY</u> - FITS IN THROUGH ITEMS #9 & #12, THIS PAGE. GUIDES CHAIN ITEM #19, PAGE 54. NOT SOLD AS AN ASSEMBLY FOR 375 OR 385.
16	P-361600	<u>IDLER SHAFT</u> - 350-360
	P-371600	<u>IDLER SHAFT</u> - 375-9800
	P-381600	<u>IDLER SHAFT</u> - 385
17	P-361620	<u>ROLLER ASSEMBLY</u>
18	P-1263	<u>BUSHING</u>
19	P-8	<u>SET SCREW</u>
20	P-361640	<u>CAM</u> - OPERATES GRIPPER BAR ARM, ITEM #9, PAGE 54.
21	P-1054	<u>RETAINING RING</u>
22	P-621	<u>WASHER</u>
23	P-381640	<u>CAM</u> - FOR 385 ONLY - OPERATES GRIPPER BAR, ITEM #18, PAGE 54.

DRAWING #55A  
CHAIN GUIDE IDLER SHAFT ASSEMBLY - (REAR) 9800, 1:1

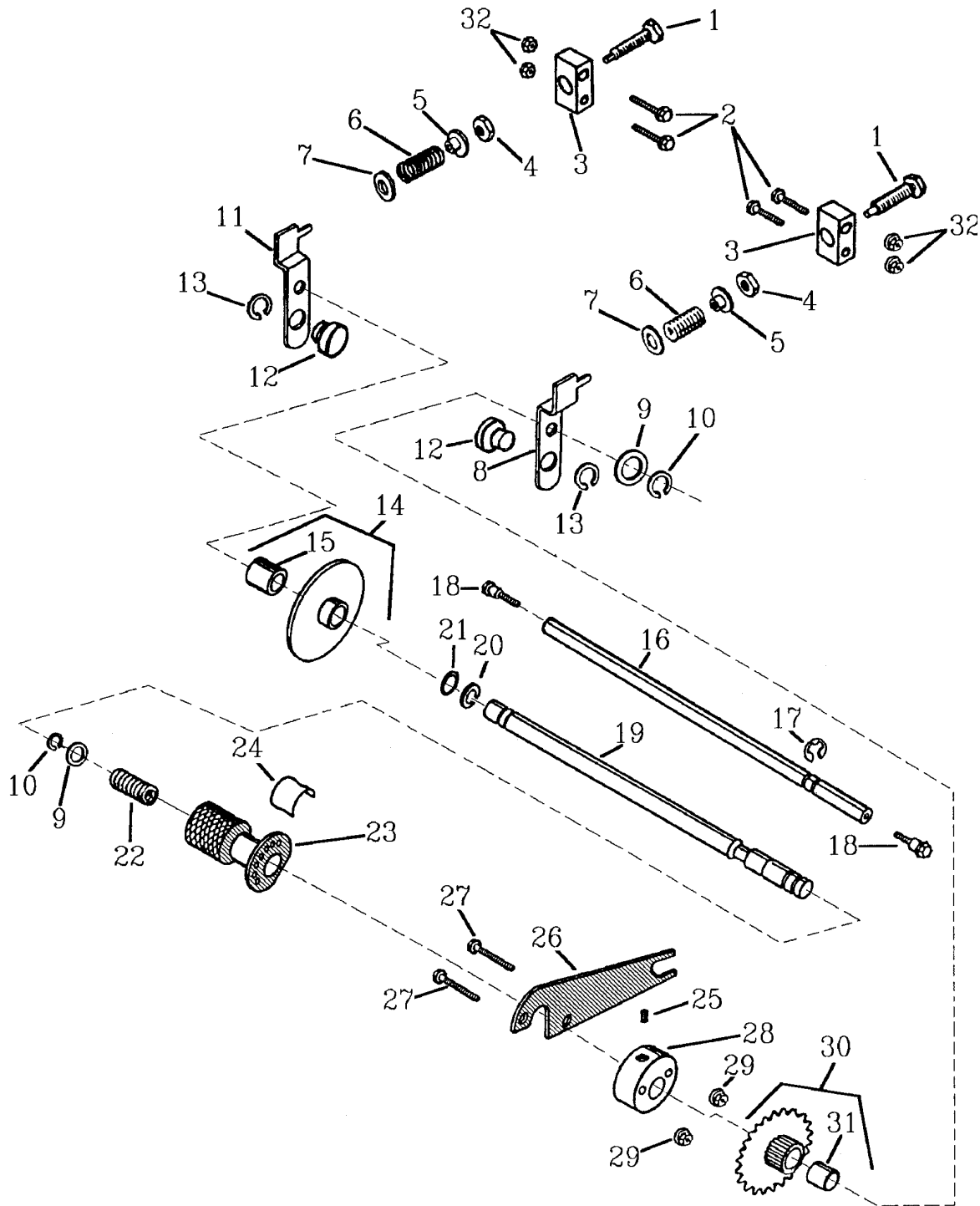



**PAGE #55A**  
**CHAIN GUIDE IDLER SHAFT ASSEMBLY - (REAR) 9800, 1-1**

KEY #	PART#	DESCRIPTION
1	P-954	<u>ADJUSTING SCREW</u>
2	P-85	<u>SCREW</u> - 2 FOR EACH BLOCK.
3	P-361460	<u>ADJUSTING BLOCK</u>
4	P-492	<u>NUT</u>
5	P-361440	<u>SPRING RETAINER</u>
6	P-361420	<u>SPRING</u>
7	P-361400	<u>SPACER</u>
8	P-981480	<u>GUIDE TENSION LEVER</u> - OPERATORS SIDE. ATTACHES OUTSIDE OF FRAME ONTO SHAFT, #16, THIS PAGE.
9	P-621	<u>WASHER</u>
10	P-1054	<u>RETAINING RING</u>
11	P-981500	<u>GUIDE TENSION LEVER</u> - NON-OPER. SIDE. ATTACHES OUTSIDE OF FRAME ONTO SHAFT, #16, THIS PAGE.
12	P-981520	<u>PIVOT STUD</u> - GOES THROUGH SIDE FRAME FROM INSIDE.
13	P-711	<u>RETAINING RING</u>
14	P-981620	<u>ROLLER ASSEMBLY</u>
15	P-1264	<u>BUSHING</u>
16	P-984020	<u>TIE BAR</u> - 9800, 1-1 ONLY.
17	P-672	<u>C-RING</u>
18	P-8036	<u>SHOULDER SCREW</u>
19	P-981600	<u>IDLER SHAFT</u>
20	P-1054	<u>RETAINING RING</u>
21	P-621	<u>WASHER</u>
22	P-981420	<u>SPRING</u>
23	P-984030	<u>CAM RELEASE ADJUSTMENT</u>
24	P-984040	<u>DECAL</u> - GOES ON ITEM #23, THIS PAGE.
25	P-8	<u>SET SCREW</u>
26	P-981640	<u>CAM</u> - OPERATES GRIPPER BAR ARM, ITEM #9, PAGE 54.
27	P-5376	<u>FLAT HEAD SCREW</u>
28	P-984010	<u>HUB ASSEMBLY</u>
29	P-5379	<u>NUT</u>
30	P-984000	<u>SPROCKET ASSEMBLY</u>
31	P-1264	<u>BUSHING</u>

**DRAWING #56**  
**REAR JOGGER & JOGGER CONTROL - 350, 360, 375, 9800 CAST FRAMES, 385**

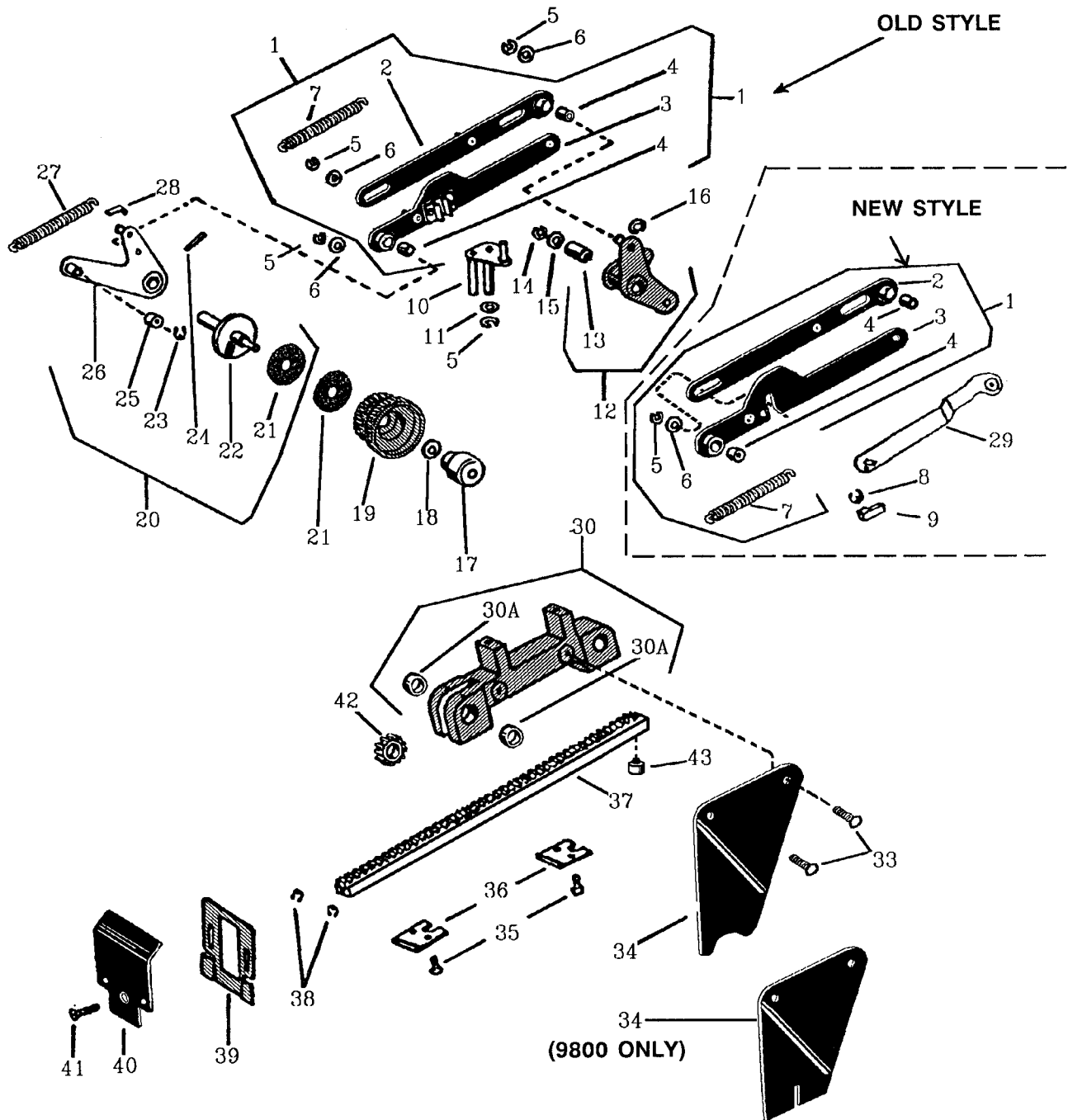

**PAGE #56**  
**REAR JOGGER & JOGGER CONTROL - 350, 360, 375, 9800 CAST FRAMES, 385**

KEY #	PART#	DESCRIPTION
1	P-361410	<u>LINK ASSEMBLY</u> - OLD STYLE.
	P-361430	<u>LINK ASSEMBLY</u> - NEW STYLE.
2	P-361450	<u>LINK</u> - NEW & OLD STYLE.
3	P-361470	<u>LINK</u> - OLD STYLE.
	P-361490	<u>LINK</u> - NEW STYLE.
4	P-811	<u>BUSHING</u>
5	P-669	<u>RING</u>
6	P-598	<u>WASHER</u>
7	P-361810	<u>SPRING</u>
8	P-726	<u>RING</u>
9	P-361550	<u>DRIVE BLOCK</u> - FOR NEW STYLE LINK ASSEMBLY.
10	P-361570	<u>PLATE ASSEMBLY</u> - OPERATES ITEM #23 PAGE 57, FOR JOGGER GUIDE.
11	P-595	<u>WASHER</u>
12	P-361590	<u>LEVER ASSEMBLY</u> - OLD STYLE.
	P-361610	<u>LEVER ASSEMBLY</u> - NEW STYLE.
13	P-825	<u>BUSHING</u>
14	P-670	<u>RING</u>
15	P-602	<u>WASHER</u>
16	P-668	<u>RING</u> - USED ON NEW STYLE ONLY.
17	P-361630	<u>KNOB NUT</u> - LOCKING.
18	P-596	<u>WASHER</u>
19	P-361650	<u>ADJUSTING KNOB</u> - OPERATED BY GEAR ITEM #19 PAGE 57. FOR LOCATION SEE ITEM #26 DRAWING 61.
20	P-361670	<u>LEVER ASSEMBLY</u> - OPERATES ITEMS #2 & #3 THIS PAGE.
21	P-361690	<u>PAD</u>
22	P-361710	<u>SHAFT</u> - MUST PURCHASE ASSEMBLY P-361670 ITEM #20 THIS PAGE. FITS IN THROUGH SIDE FRAME, SEE ITEM #13 DRAWING 61.
23	P-698	<u>RING</u>
24	P-442	<u>TAPER PIN</u>
25	P-361730	<u>ROLLER</u>
26	P-361750	<u>LEVER</u> - LEVER NOT SOLD SEPARATELY. SEE ITEM 20 THIS PAGE.
27	P-361770	<u>SPRING</u> - ATTACHES TO ITEM #9 DRAWING 61. (ALSO SEE ITEM 9, PAGE 60)
28	P-361790	<u>SPRING CLIP</u> - ATTACHES ONTO ITEMS #26 & #27 THIS PAGE.
29	P-361530	<u>LINK</u> - FOR NEW STYLE ONLY.
30	P-361830	<u>SUPPORT ASSEMBLY</u> - MOUNTS ON TIE BAR ITEM #10 & #18 PAGE 57. ALSO FOR COVER ITEM #30 PAGE 10.
30A	P-1260	<u>BUSHING</u>
33	P-92	<u>SCREW</u>
34	P-361870	<u>SUPPORT PLATE</u> - (RESTS ON TIE BAR, SEE ITEM #11, PAGE 49.) 350-360-375 & 385
	P-981870	<u>SUPPORT PLATE</u> - (RESTS ON BASE FRAME OF PRESS.) 9800 - ONLY SEE PAGE 49.)
35	P-260	<u>SCREW</u>
36	P-361890	<u>PLATE</u>
37	P-361910	<u>GEAR TRACK</u> - OPERATED BY GEAR, ITEM #42, THIS PAGE.
38	P-668	<u>RING</u>
39	P-362930	<u>PLATE</u>
40	P-361950	<u>JOGGER PLATE</u>
41	P-999	<u>SCREW</u>
42	P-361970	<u>GEAR</u>
4	P-7010	<u>STOP SCREW</u>

**DRAWING #56A**  
**REAR JOGGER & JOGGER CONTROL - 9800, 1:1**

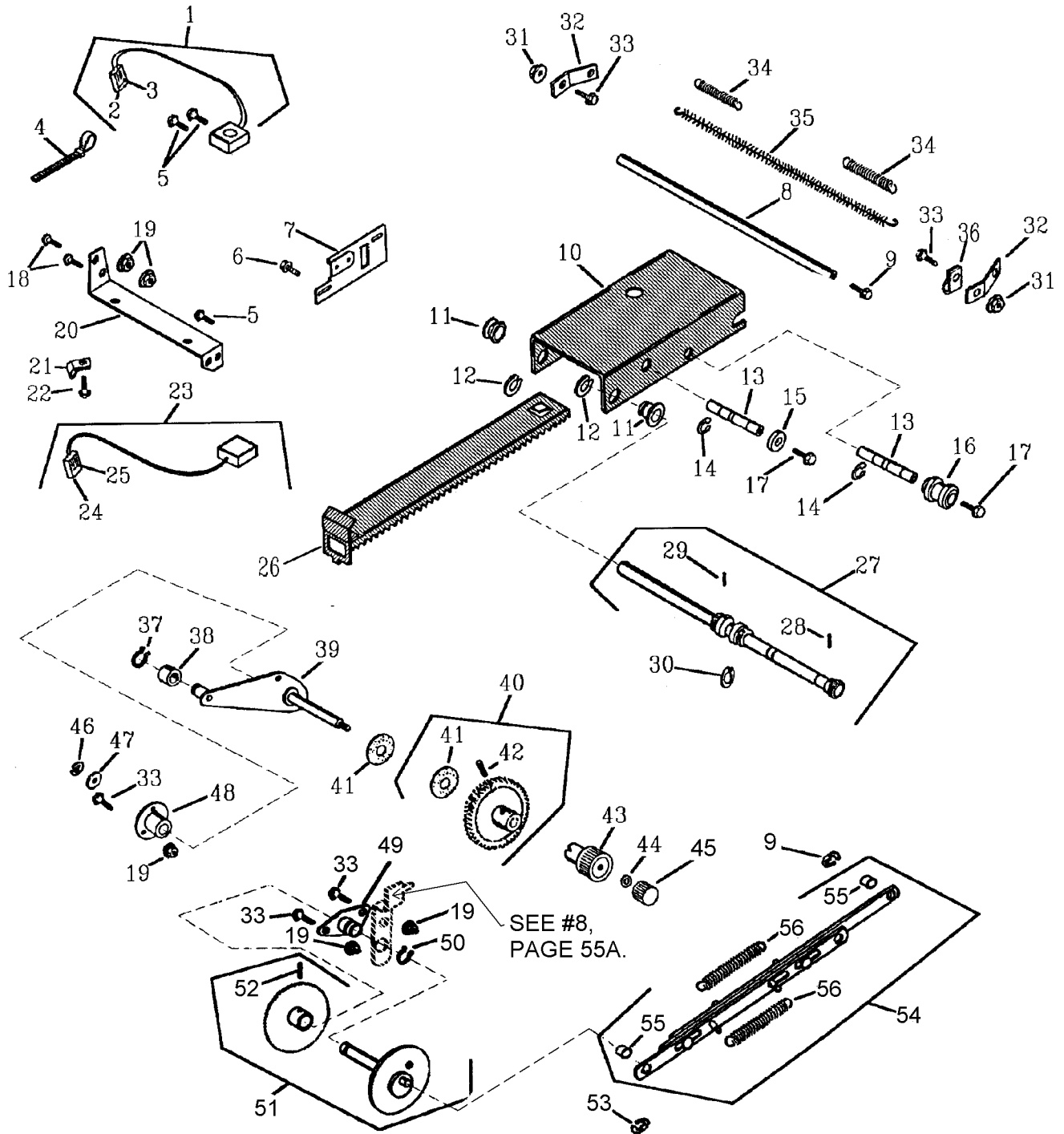

**PAGE #56A**  
**REAR JOGGER & JOGGER CONTROL - 9800, 1-1**

KEY #	PART#	DESCRIPTION
1	P-984050	<u>LAMP ASSEMBLY</u> - LOWER.
2	P-4089	<u>TERMINAL PIN</u>
3	P-984060	<u>PLUG</u>
4	P-1837	<u>CABLE TIE</u>
5	P-194	<u>SCREW</u>
6	P-235	<u>SCREW</u>
7	P-984070	<u>BRACKET</u> - FOR LAMP ASSEMBLY, ITEM #1 THIS PAGE. MOUNTS TO ITEM #10 THIS PAGE.
8	P-37655	<u>TIE BAR</u> - SEE ITEM #8 PAGE 46 ON LOWER SIDE FRAMES.
9	P-8012	<u>SHOULDER SCREW</u>
10	P-981830	<u>BACK JOGGER HOUSING MOUNT</u>
11	P-5810	<u>BUSHING</u>
12	P-687	<u>C-RING</u>
13	P-984080	<u>SHAFT</u> - MOUNTS IN DISC HOUSING ITEM #10 THIS PAGE.
14	P-684	<u>C-RING</u>
15	P-5811	<u>ROLLER</u> - REAR.
16	P-5812	<u>ROLLER</u> - UPPER.
17	P-5353	<u>SCREW</u>
18	P-995	<u>SCREW</u>
19	P-472	<u>NUT</u>
20	P-984090	<u>BRACKET</u>
21	P-1839	<u>CABLE CLAMP</u>
22	P-112	<u>TAPPING SCREW</u>
23	P-984100	<u>PHOTOTRANSISTOR</u>
24	P-984110	<u>PLUG</u>
25	P-4090	<u>PIN</u>
26	P-981910	<u>GEAR TRACK</u>
27	P-981920	<u>JOGGER CONTROL SHAFT GEAR ASSEMBLY</u>
28	P-424	<u>TAPER PIN</u>
29	P-5703	<u>TAPER PIN</u>
30	P-687	<u>C-RING</u>
31	P-471	<u>NUT</u>
32	P-98657	<u>TINSEL BRACKET</u>
33	P-81	<u>SCREW</u>
34	P-36653	<u>SPRING</u>
35	P-36673	<u>TINSEL</u> - SOLD AS 72 Ft. LENGTHS.
	P-36658	<u>TINSEL</u> - SOLD AS 10 Ft. LENGTHS.
	P-36654	<u>TINSEL</u> - SOLD AS 1 Ft. LENGTHS.
36	P-1840	<u>CABLE CLAMP</u>
37	P-698	<u>C-RING</u>
38	P-361730	<u>CAM ROLLER</u>
39	P-981750	<u>LEVER</u>
40	P-984120	<u>GEAR ASSEMBLY</u> - (FLAT STEEL FRAMES) 9800, 1-1 CHAIN DELIVERY.
40	P-984121	<u>GEAR ASSEMBLY</u> - (CAST ALUMINUM FRAMES)
41	P-361690	<u>PAD</u>
42	P-517	<u>SPIRAL PIN</u>
43	P-981650	<u>KNOB</u> - OPERATES JOGGER MECHANISM, ITEM #26 THIS PAGE.
44	P-596	<u>WASHER</u>
45	P-981630	<u>KNOB NUT</u>
46	P-673	<u>C-RING</u>
47	P-1814	<u>WASHER</u>
48	P-982100	<u>HOUSING</u>
49	P-984170	<u>BEARING</u>
50	P-711	<u>C-RING</u>
51	P-984160	<u>CRANK ASSEMBLY</u>
52	P-436	<u>TAPER PIN</u>
53	P-669	<u>RETAINING RING</u>
54	P-981430	<u>LINK ASSEMBLY</u> - REAR JOGGER MECHANISM. LOCATED ON OUTSIDE OF SIDE FRAME ON NON-OPERATORS SIDE. CONNECTS TO ITEM #39, PAGE 56A.
55	P-812	<u>BUSHING</u>
56	P-981810	<u>SPRING</u>

**DRAWING #57**  
**SIDE JOGGER & SIDE JOGGER CONTROL**  
**350, 360, 375, 9800 CAST FRAMES, 385**

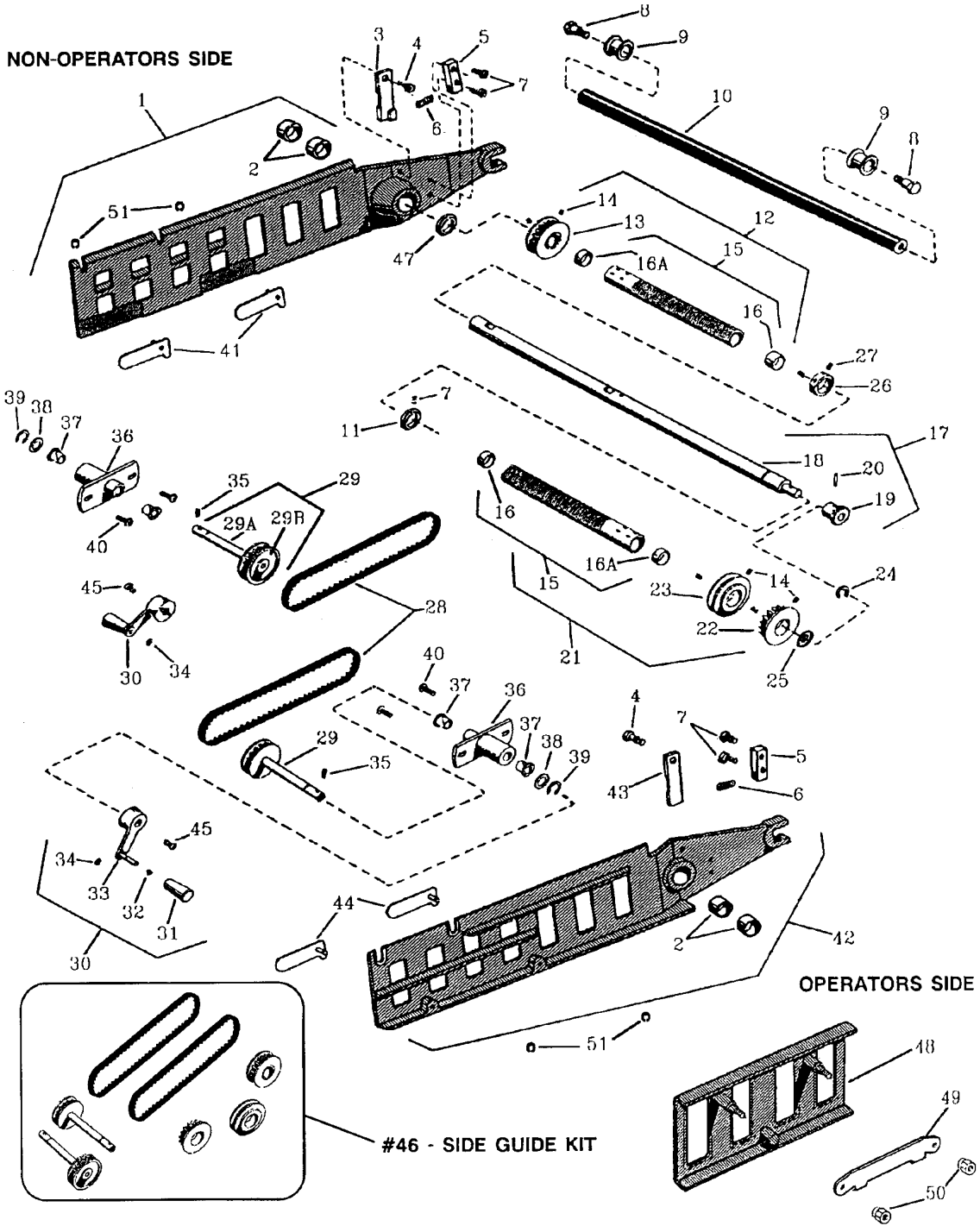

## SIDE JOGGER &amp; SIDE JOGGER CONTROL - 350, 360, 375, 9800 CAST FRAMES, 385

KEY #	PART#	DESCRIPTION
1	P-361660	<u>L.H. JOGGER PLATE</u> - FIT ONTO ITEM #9 & #10, THIS PAGE.
2	P-1299	<u>BUSHING</u>
3	P-361680	<u>PRESSURE PAD</u> - MOUNTS TO JOGGER PLATE, NON-OPERATORS SIDE.
4	P-8035	<u>SHOULDER SCREW</u>
5	P-361720	<u>PRESSURE BLOCK</u>
6	P-361740	<u>SPRING</u>
7	P-266	<u>SCREW</u>
8	P-896	<u>SHOULDER SCREW</u>
9	P-361780	<u>GLIDER SLEEVE</u> - FOR ITEMS #1 & #42, THIS PAGE.
10	P-361800	<u>TIE BAR</u> - 350, 360 - MOUNTS TO SIDE FRAMES, SEE ITEM #7, DWG. #61.
	P-371800	<u>TIE BAR</u> - 375, 9800 - MOUNTS TO SIDE FRAMES, SEE ITEM #7, DWG. #61.
	P-381800	<u>TIE BAR</u> - 385 - MOUNTS TO SIDE FRAMES, SEE ITEM #7, DWG. #61.
11	P-361820	<u>SPACER</u> - FLANGED.
12	P-361860	<u>JOGGER PULLEY ASSEMBLY</u> - L.H. (SEE NOTE).
	OBSOLETE	<u>JOGGER SCREW ASSEMBLY</u> - FOR 385 - USE P-361840 PULLEY KIT AND P-381900 JOGGER SCREW, ITEM #15.
13	P-361880	<u>PULLEY</u>
14	P-849	<u>SET SCREW</u>
15	P-361900	<u>JOGGER SCREW</u> - 350, 360.
	P-371900	<u>JOGGER SCREW</u> - 375, 9800.
	P-381900	<u>JOGGER SCREW</u> - 385.
16	P-1247	<u>BUSHING</u>
16A	P-1246	<u>BUSHING</u>
17	P-361920	<u>SHAFT &amp; GEAR ASSEMBLY</u> - 350, 360. MOUNTS THROUGH SIDE FRAME. SEE ITEM #22, DWG. 61.
	P-371920	<u>SHAFT &amp; GEAR ASSEMBLY</u> - 375. MOUNTS THROUGH SIDE FRAME. SEE ITEM #22, DWG. 61.
	P-381920	<u>SHAFT ASSEMBLY</u> - 385.
18	P-361940	<u>SHAFT</u> - NOT SOLD SEPARATELY AT THIS TIME, USE P-361920.
	P-371940	<u>SHAFT</u> - NOT SOLD SEPARATELY AT THIS TIME, USE P-371920.
	P-381940	<u>SHAFT</u> - NOT SOLD SEPARATELY AT THIS TIME, USE P-381920.
19	P-361960	<u>GEAR</u> - OPERATED BY ITEM #19, PAGE 56.
20	P-442	<u>TAPER PIN</u>
21	P-361980	<u>JOGGER PULLEY ASSEMBLY</u> - R.H. 350, 360, 375. (SEE NOTE)
	OBSOLETE	<u>JOGGER SCREW &amp; GUIDE ASSEMBLY</u> - FOR 385. USE P-361840 PULLEY KIT & P-381900 SCREW, ITEM #15.
22	P-362000	<u>PULLEY</u>
23	P-362020	<u>JOGGER GUIDE</u> - OPERATED BY ITEM #10, PAGE #56. (INCLUDES ITEMS #14 & #15.)
24	P-673	<u>C-RING</u>
25	P-1814	<u>WASHER</u>
26	P-362060	<u>COLLAR</u> - 350, 360, 385.
	P-372060	<u>SPACER</u> - 375, 9800.
27	P-7	<u>SET SCREW</u>
28	P-1658	<u>BELT</u>
	P-361560	<u>CHAIN</u> - FOR OLD STYLE SPROCKETS.
29	P-362080	<u>SHAFT &amp; PULLEY ASSEMBLY</u> - FOR 350, 360, 385. (2-3/4" SHAFT).
	P-372080	<u>TIMING PULLEY</u> - 375, 9800. (3-5/8" SHAFT).
29A	P-362040	<u>SHAFT</u> - FOR 350, 360, 385.
	P-372040	<u>SHAFT</u> - 375, 9800.
29B	P-362120	<u>PULLEY (ONLY)</u>
30	P-36060	<u>HAND CRANK ASSEMBLY</u> - SEE ITEM #25, DWG. #61.
31	P-36062	<u>KNOB</u>
32	P-36410	<u>SPRING</u>
33	P-36061	<u>HANDLE</u>
34	P-10	<u>SET SCREW</u>
35	P-380	<u>ROLL PIN</u>
36	P-362100	<u>CRANK SHAFT HOUSING</u> - ATTACHES TO OUTSIDE OF SIDE FRAME, SEE ITEM #12, DWG. #61.
37	P-1817	<u>PLASTIC BEARING</u>
38	P-602	<u>WASHER</u>
39	P-670	<u>C-RING</u>
40	P-262	<u>SCREW</u>
41	P-362140	<u>JOGGER EXTENSION GUIDES</u> - L.H.
42	P-362160	<u>R.H. JOGGER PLATE</u> - INCLUDES ITEM #2.
43	P-362180	<u>PRESSURE PAD</u>
44	P-362200	<u>JOGGER EXTENSION GUIDES</u> - R.H.
45	P-299	<u>SCREW</u>
46	P-361840	<u>SIDE GUIDE KIT</u> - 350, 360, 385. (SEE NOTE). CONSISTS OF....
	P-371840	<u>SIDE GUIDE KIT</u> - 375, 9800. (SEE NOTE). CONSISTS OF....
		2 EA. P-1658 Belts, item #28.
		2 EA. P-362080 Shaft & pulley assembly, item #29 (included in 350, 360 & 385 only)
		2 EA. P-372080 Shaft & pulley assembly, item #29 (included in 375, 9800 only)
		1 EA. P-361880 Pulley, item #13.
		1 EA. P-362020 Jogger guide, item #23.
		1 EA. P-362000 Pulley, item #22.
47	P-1615	<u>SPACER</u> - 375 ONLY.
48	P-382160	<u>AUXILIARY JOGGER</u> - 385. ATTACHES ONTO JOGGERS, ITEMS #1 OR #42.
49	P-382200	<u>JOGGER CLAMP</u> - 385.
50	P-382140	<u>NUT</u> - 385.
51	P-668	<u>C-RING</u>
		<b>NOTE:</b> OLD STYLE SPROCKET AND CHAIN IS NOW OBSOLETE. CHANGE TO AN IMPROVED BELT AND PULLEY SYSTEM. IT'S EASY TO INSTALL AND SAVES MONEY ON REPAIR COSTS.

DRAWING #57A  
SIDE JOGGERS, SIDE JOGGER CONTROL & REAR JOGGER CONTROL - 9800, 1:1

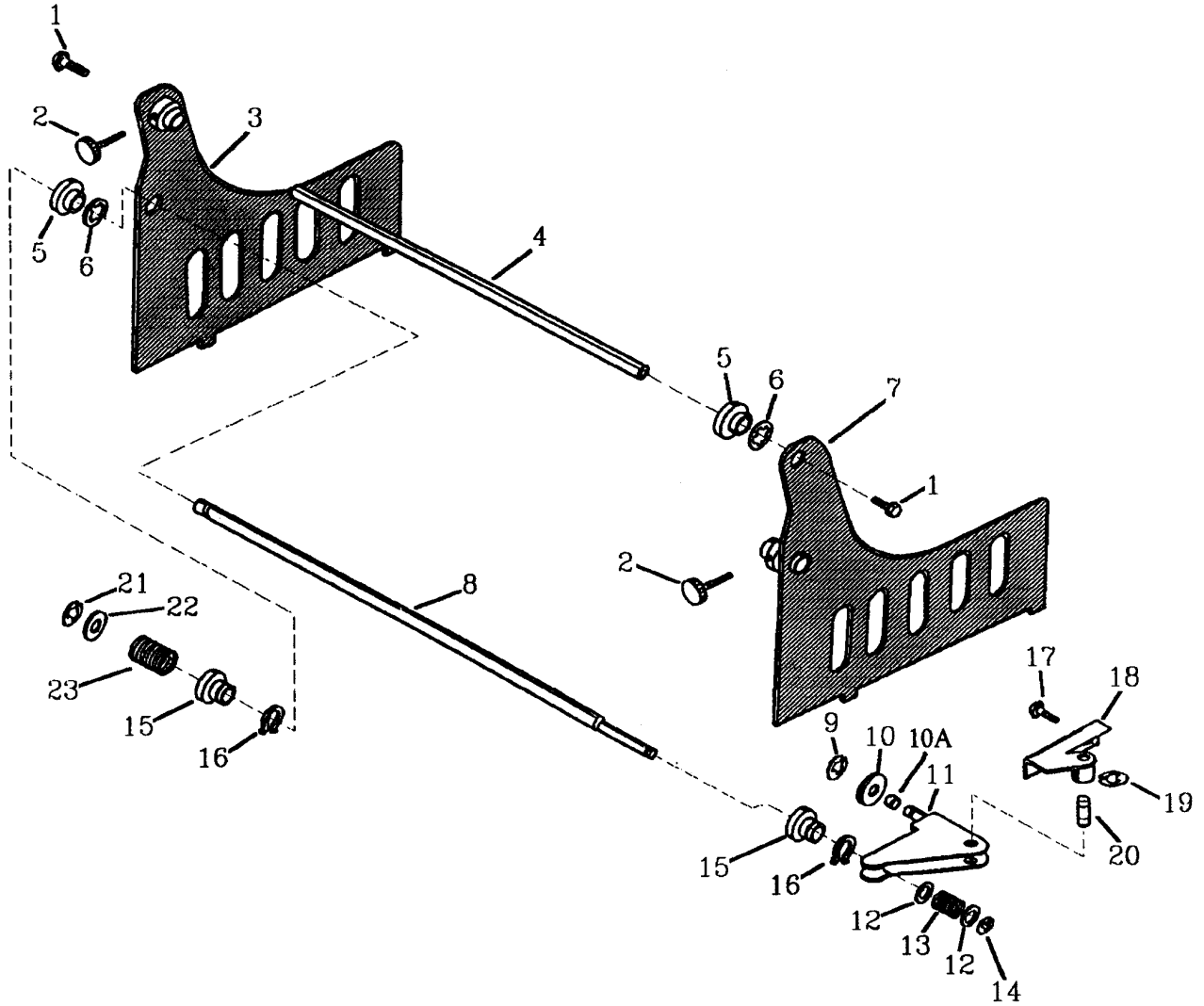



**PAGE #57A**  
**SIDE JOGGERS, SIDE JOGGER CONTROL & REAR JOGGER CONTROL - 9800, 1-1**

KEY #	PART#	DESCRIPTION
1	P-8036	<u>SHOULDER SCREW</u>
2	P-5356	<u>THUMB SCREW</u>
3	P-981660	<u>L.H. JOGGER PLATE</u>
4	P-981800	<u>TIE BAR</u>
5	P-1333	<u>FLANGED BUSHING</u>
6	P-5336	<u>PUSH-ON WASHER</u>
7	P-982160	<u>R.H. JOGGER PLATE</u>
8	P-984180	<u>SHAFT</u>
9	P-669	<u>C-RING</u>
10	P-5507	<u>CAM ROLLER</u>
10A	P-812	<u>BUSHING</u>
11	P-984130	<u>SIDE JOGGER CONTROL LEVER</u>
12	P-601	<u>WASHER</u>
13	P-36477	<u>SPRING</u>
14	P-670	<u>C-RING</u>
15	P-5810	<u>FLANGED BUSHING</u>
16	P-687	<u>C-RING</u>
17	P-5353	<u>SCREW</u>
18	P-984140	<u>SUPPORT ASSEMBLY</u> - ATTACHES TO SIDE FRAME.
19	P-668	<u>C-RING</u>
20	P-3014	<u>PIN</u>
21	P-672	<u>C-RING</u>
22	P-614	<u>WASHER</u>
23	P-984150	<u>SPRING</u> - LOCATED ON OUTSIDE OF SIDE OF SIDE FRAME ON NON-OPERATORS SIDE.

**DRAWING #58**  
**RECEDING PILE CONTROL LEVER & GEARS - 350, 360, 375, 9800 CAST FRAMES, 385**

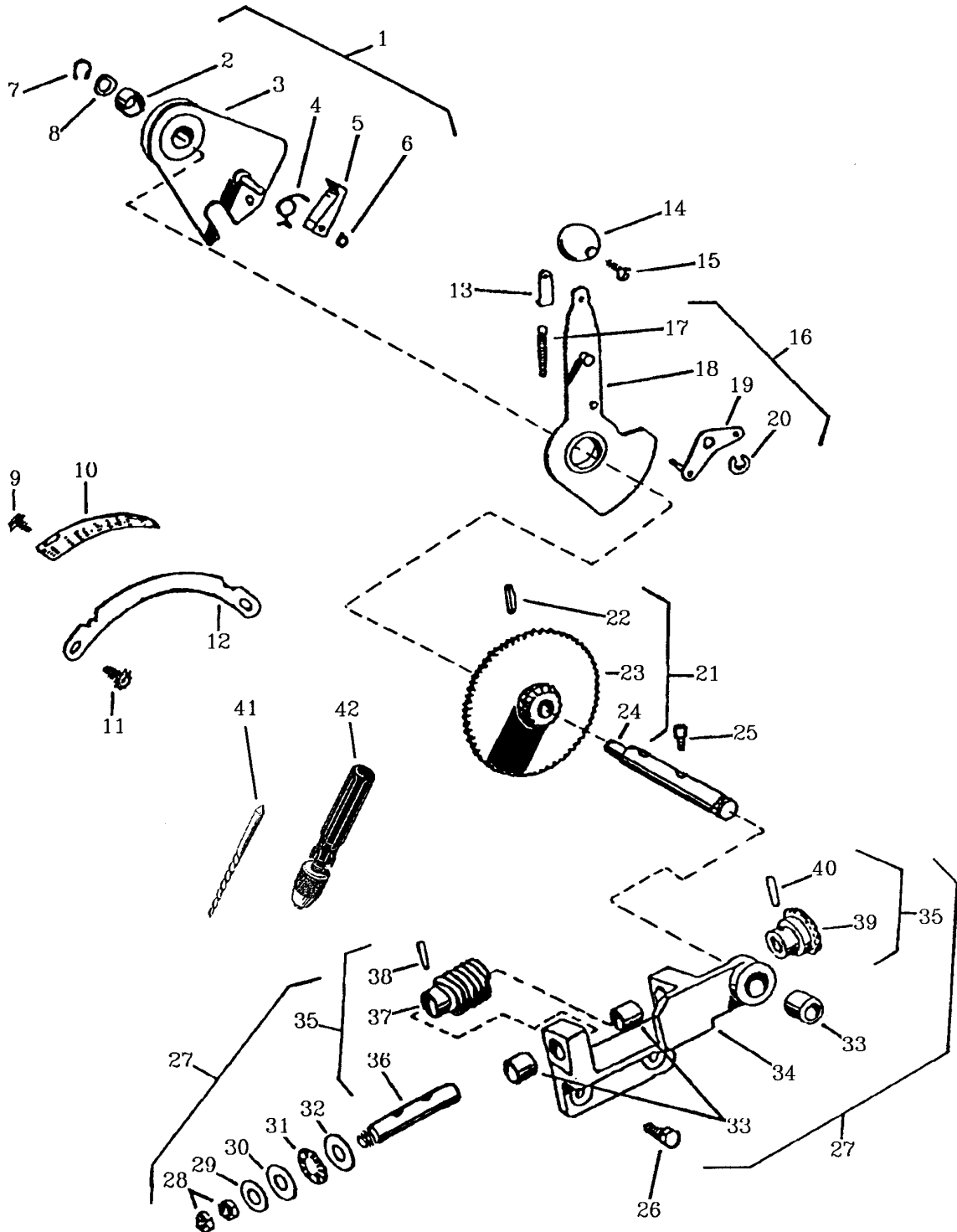

## RECEDING PILE CONTROL LEVER &amp; GEARS - 350, 360, 375, 9800 CAST FRAMES, 385

KEY #	PART#	DESCRIPTION
1	P-361930	<u>MOUNT ASSEMBLY</u>
2	P-1218	<u>BUSHING</u>
3	P-361510	<u>MOUNT</u>
4	P-361990	<u>SPRING</u>
5	P-362010	<u>PAWL</u> - OPERATES ITEM #23 THIS PAGE.
6	P-698	<u>RETAINING RING</u>
7	P-703	<u>RETAINING RING</u>
8	P-602	<u>WASHER</u>
9	P-239	<u>SCREW</u>
10	P-362030	<u>CONTROL INDICATOR PLATE</u> - SCREWS ONTO COVER. SEE ITEM #10 DRAWING 61.
11	P-260	<u>SCREW</u>
12	P-362050	<u>CONTROL LEVER RATCHET</u>
13	P-362070	<u>POINTER</u>
14	P-36270	<u>CONTROL KNOB</u>
15	P-993	<u>SCREW</u>
16	P-362110	<u>CONTROL LEVER ASSEMBLY</u>
17	P-362130	<u>SPRING</u>
18	P-362150	<u>LEVER</u>
19	P-362170	<u>LEVER</u>
20	P-669	<u>RETAINING RING</u>
21	P-362190	<u>SHAFT ASSEMBLY</u>
22	P-382	<u>PIN</u>
23	P-362210	<u>RATCHET &amp; GEAR</u> - NOT SOLD SEPARATELY AT THIS TIME, USE P-362190. OPERATES GEAR, ITEM #39 THIS PAGE.
24	P-362230	<u>SHAFT</u> - FITS THROUGH SIDE FRAME. SEE ITEM #20 DRAWING 61. NOT SOLD SEPARATELY AT THIS TIME, USE P-362190.
25	P-7002	<u>PIN</u>
26	P-8036	<u>SHOULDER SCREW</u>
27	P-362290	<u>GEAR &amp; SUPPORT ASSEMBLY</u>
28	P-506	<u>NUT</u>
29	P-601	<u>WASHER</u>
30	P-1951	<u>RACE</u>
31	P-780	<u>BEARING</u>
32	P-615	<u>WASHER</u>
33	P-1220	<u>BUSHING</u>
34	P-362350	<u>SUPPORT</u> - ATTACHES TO SIDE FRAME ON NON-OPERATORS SIDE. SEE ITEM #11 DRAWING 61.
35	P-362370	<u>SHAFT ASSEMBLY</u> - NEED PROPER TOOLS TO INSTALL IF GEAR & SHAFT ARE PURCHASED SEPARATELY. REAMER BIT P-1590 ITEM #41 & HAND REAMER TOOL P-1546 ITEM #42.
36	P-362390	<u>SHAFT</u>
37	P-36014	<u>WORM GEAR</u> - OPERATES ITEM #15 PAGE 59. NEED PROPER TOOLS TO INSTALL IF GEAR & SHAFT ARE PURCHASED SEPARATELY. REAMER BIT P-1590 ITEM #41 & HAND REAMER TOOL P-1546 ITEM #42.
38	P-435	<u>PIN</u>
39	P-362360	<u>BEVEL GEAR</u> - OPERATED BY RATCHET & GEAR, ITEM #23 THIS PAGE.
40	P-401	<u>PIN</u>
41	P-1590	<u>TAPERED REAMER BIT</u>
42	P-1546	<u>HAND REAMER TOOL</u>

DRAWING #58A  
RECEDING PILE CONTROL LEVER & GEARS - 9800, 1:1

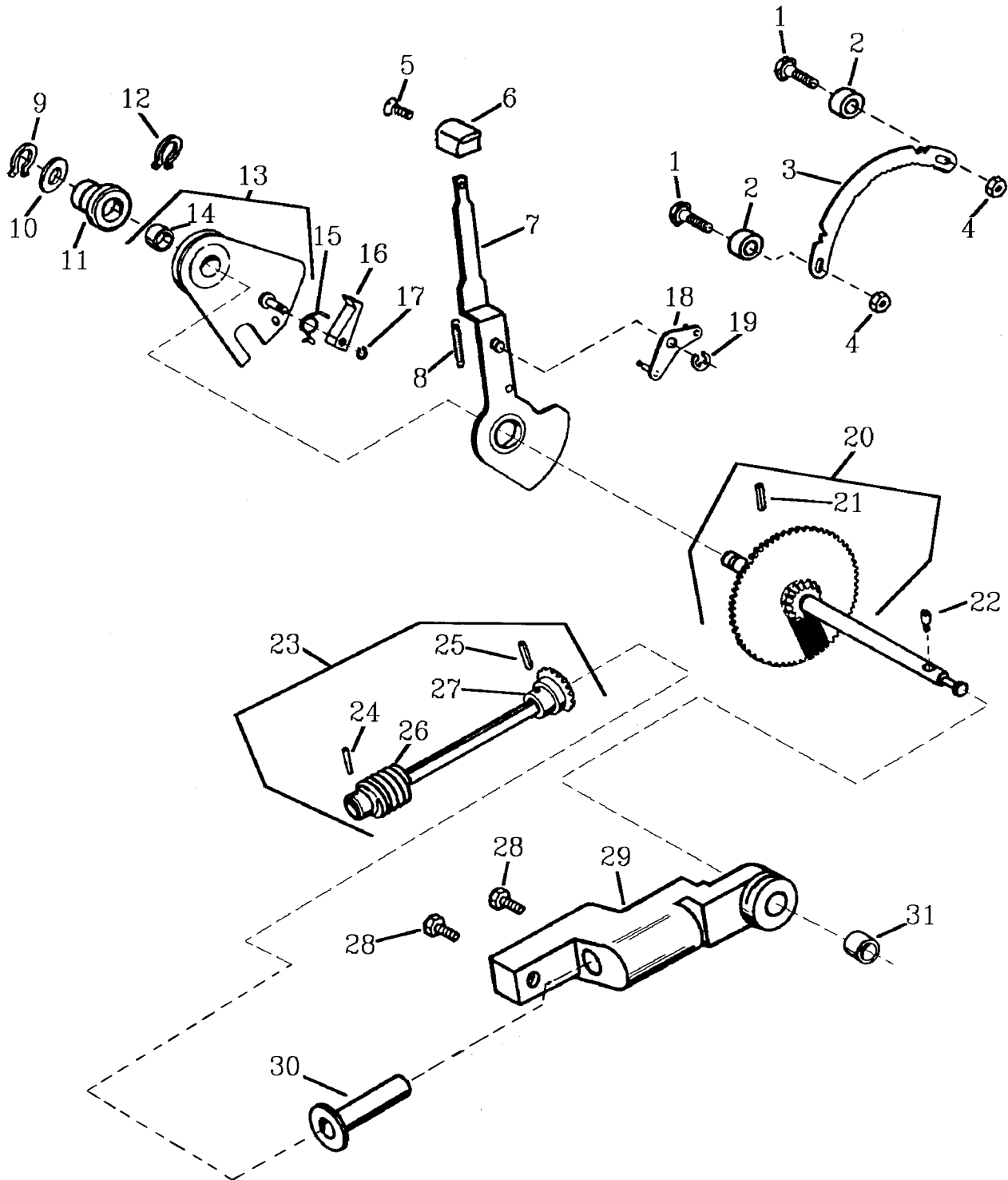

**PAGE #58A**  
**RECEDING PILE CONTROL LEVER & GEARS - 9800, 1-1**

KEY #	PART#	DESCRIPTION
1	P-936	<u>SCREW</u>
2	P-5511	<u>SPACER</u>
3	P-362050	<u>CONTROL LEVER ASSEMBLY</u>
4	P-469	<u>NUT</u>
5	P-245	<u>SCREW</u>
6	P-984200	<u>KNOB</u>
7	P-982150	<u>LEVER</u>
8	P-362130	<u>SPRING</u> - CONNECTS TO ITEM #18 & #7 THIS PAGE.
9	P-703	<u>RETAINING RING</u>
10	P-602	<u>WASHER</u>
11	P-5813	<u>BUSHING</u> - GOES THROUGH SIDE FRAME ON OPERATORS SIDE.
12	P-5337	<u>RETAINING RING</u>
13	P-981510	<u>MOUNT ASSEMBLY</u>
14	P-1218	<u>BUSHING</u>
15	P-361990	<u>SPRING</u>
16	P-362010	<u>PAWL</u>
17	P-698	<u>RETAINING RING</u>
18	P-362170	<u>LEVER</u>
19	P-669	<u>C-RING</u>
20	P-982190	<u>SHAFT ASSEMBLY</u>
21	P-382	<u>ROLL PIN</u>
22	P-7002	<u>PIN</u>
23	P-982370	<u>SHAFT &amp; GEAR ASSEMBLY</u> - OPERATES ITEM #8 PAGE 59A.
24	P-431	<u>TAPER PIN</u>
25	P-401	<u>ROLL PIN</u>
26	P-36014	<u>WORM GEAR</u> - OPERATES ITEM #15 PAGE 59. NEED PROPER TOOLS TO INSTALL IF GEAR IS PURCHASED SEPARATELY. P-1590 REAMER ITEM #32 & P-1546 HAND REAMER TOOL ITEM #33.
27	P-362360	<u>BEVEL GEAR</u> - OPERATED BY RATCHET & GEAR, ITEM #20 THIS PAGE.
28	P-8036	<u>SHOULDER SCREW</u>
29	P-982350	<u>SUPPORT</u> - ATTACHES TO FRAME ON OPERATORS SIDE. SEE ITEM #11 DRAWING 61.
30	P-5814	<u>BEARING</u>
31	P-1220	<u>BUSHING</u>
32	P-1590	<u>REAMER BIT</u> - NOT SHOWN.
33	P-1546	<u>HAND REAMER TOOL</u> - NOT SHOWN.

**DRAWING #59**  
**TABLE RAISE SHAFT, CHAIN GUIDES & DOLLY BOARD SUPPORTS**  
**350, 360, 375, 385**

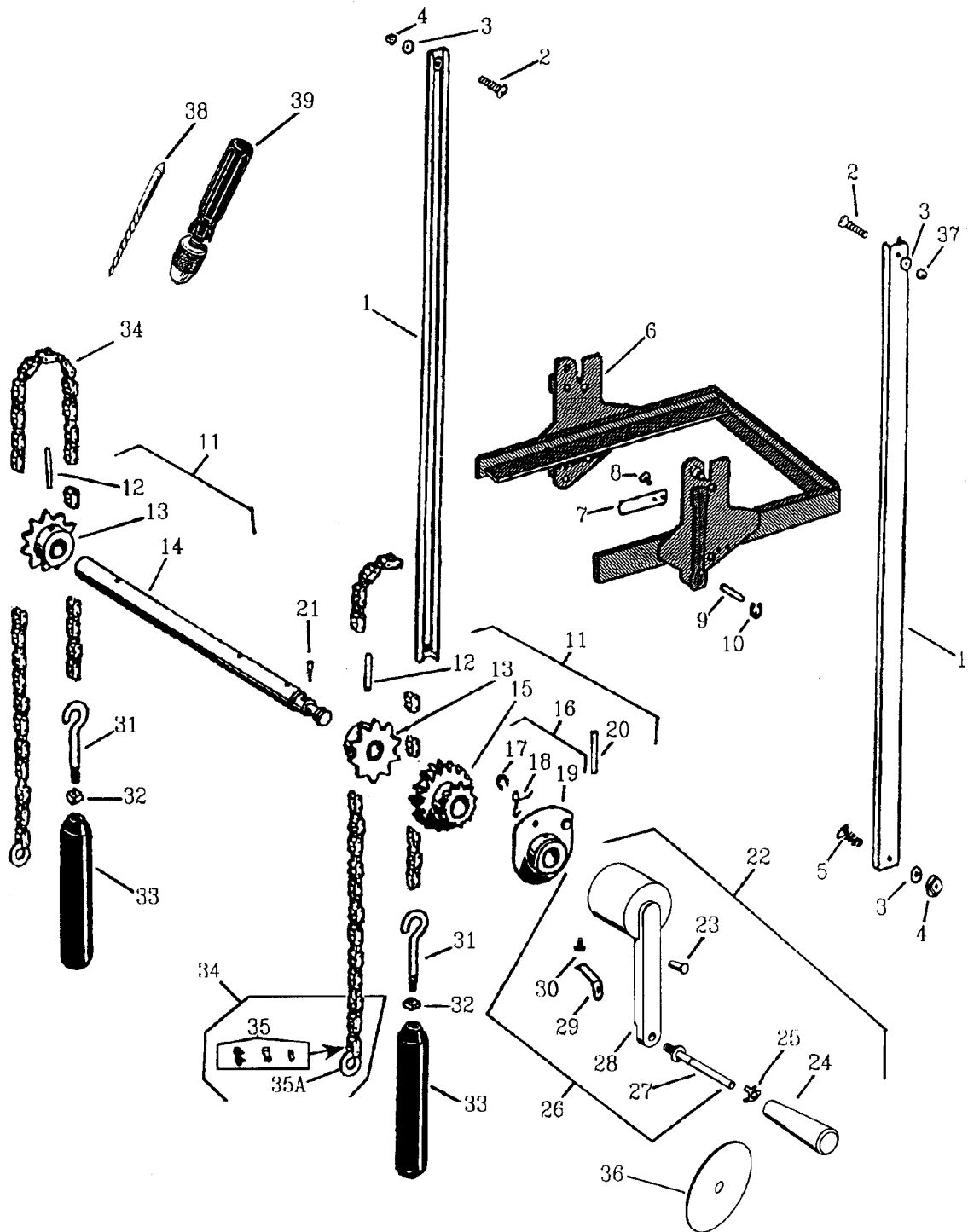

## TABLE RAISE SHAFT, CHAIN GUIDES &amp; DOLLY BOARD SUPPORTS - 350, 360, 375, 385

KEY #	PART#	DESCRIPTION
1	P-362090	<u>GUIDE</u> - LH/RH TABLE RAISE TRACK. MOUNTS TO INSIDE SIDE FRAME, SEE ITEM #27, DWG 61.
2	P-1012	<u>SCREW</u>
3	P-645	<u>WASHER</u>
4	P-281	<u>CAP NUT</u> - NOT NEEDED ON UPPER HALF OF OPERATORS SIDE.
5	P-1011	<u>SCREW</u> - SAME PART NUMBER FOR LEFT AND RIGHT SIDE.
6	P-362410	<u>SUPPORT TABLE ASSEMBLY</u> - 350, 360. RIDES IN GUIDES, #1, THIS PAGE. (SUPPORT FOR DOLLY BOARD, ITEM #22, PAGE 62).
	P-372410	<u>SUPPORT TABLE ASSEMBLY</u> - 375, 9800. RIDES IN GUIDES #1, THIS PAGE. (SUPPORT FOR DOLLY BOARD, ITEM #22, PAGE 62).
	P-982410	<u>SUPPORT TABLE ASSEMBLY</u> - 385. RIDES IN GUIDES, ITEM #1, THIS PAGE. (SUPPORT FOR DOLLY BOARD, ITEM #22, PAGE 62).
7	P-362430	<u>SPRING</u>
8	P-254	<u>SCREW</u>
9	P-3004	<u>PIN</u>
10	P-668	<u>RING</u>
11	P-362470	<u>SHAFT ASSEMBLY</u> - FITS THROUGH SIDE FRAME, SEE ITEM #21, DWG. 61.
	P-372470	<u>SHAFT ASSEMBLY</u> - FITS THROUGH SIDE FRAME, SEE ITEM #21, DWG. 61.
	P-382470	<u>SHAFT ASSEMBLY</u> - FITS THROUGH SIDE FRAME, SEE ITEM #21, DWG. 61.
12	P-433	<u>PIN</u>
13	P-362490	<u>SPROCKET</u> - NOT SOLD SEPARATELY. MUST BUY FULL ASSEMBLY #P-362470, ITEM #11, THIS PAGE.
14	P-362510	<u>SHAFT</u> - 350, 360. SOLD SEPARATELY BUT MUST HAVE PROPER TOOLS TO INSTALL-REAMER P-1590 & TOOL P-1546.
	P-372510	<u>SHAFT</u> - 375, 9800. NOT SOLD SEPARATELY, MUST BUY FULL ASSEMBLY P-372470, ITEM #11, THIS PAGE.
	P-382510	<u>SHAFT</u> - 385. NOT SOLD SEPARATELY, MUST BUY FULL ASSEMBLY P-382470, ITEM #11, THIS PAGE.
15	P-362530	<u>GEAR</u> - OPERATED BY ITEM #37, PAGE 58, & ITEM #26, PAGE 58A.
16	P-362550	<u>MOUNT ASSEMBLY</u> - NOT SOLD SEPARATELY. MUST BUY FULL ASSEMBLY P-362470, ITEM #11, THIS PAGE.
17	P-666	<u>RING</u>
18	P-362570	<u>SPRING</u>
19	P-362590	<u>MOUNT</u> - NOT SOLD SEPARATELY, MUST BUY FULL ASSEMBLY P-362470, ITEM #11, THIS PAGE.
20	P-393	<u>PIN</u>
21	P-7002	<u>PIN</u>
22	P-362630	<u>HAND CRANK ASSEMBLY</u> - COMPLETE - SEE ITEMS #23 & #24, DWG. 61.
23	P-318	<u>RIVET</u> - <b>OLD STYLE. NOT PART OF P-362630.</b> (THIS IS AN OPTIONAL REPLACEMENT FOR O.E.M. ASSEMBLY ONLY).
		(WE ARE USING P-11963, ITEM #30A IN PLACE OF THIS ON <u>OUR</u> ASSEMBLY AND AS A REPLACEMENT PIECE FOR USE ON <u>OUR</u> ASSEMBLY).
24	P-36961	<u>HANDLE</u>
25	P-36959	<u>SPRING LOCK</u>
26	P-362710	<u>CRANK &amp; STUD ASSEMBLY</u>
27	P-36962	<u>HANDLE SHAFT</u>
28	P-362730	<u>CRANK</u>
29	P-362570	<u>SPRING</u> - <b>OLD STYLE. NOT PART OF P-362630.</b> (THIS IS AN OPTIONAL REPLACEMENT FOR O.E.M. ASSEMBLY ONLY). (WE ARE USING P-11963, ITEM #30A IN PLACE OF THIS ON <u>OUR</u> ASSEMBLY AND AS A REPLACEMENT PIECE FOR USE ON <u>OUR</u> ASSEMBLY).
30	P-3003	<u>STUD</u> - <b>OLD STYLE. NOT PART OF P-362630.</b> (THIS IS AN OPTIONAL REPLACEMENT FOR O.E.M. ASSEMBLY ONLY).
		(WE ARE USING P-11963, ITEM #30A IN PLACE OF THIS ON <u>OUR</u> ASSEMBLY AND AS A REPLACEMENT PIECE FOR USE ON <u>OUR</u> ASSEMBLY).
30A	P-11963	<u>BALL PLUNGER</u> - NEW STYLE. COMES WITH ASSEMBLY P-362630. SEE NOTES FOR ITEMS #23, #29, #30.
31	P-1038	<u>HOOK</u>
32	P-469	<u>NUT</u>
33	P-362810	<u>WEIGHT</u>
34	P-36105	<u>CHAIN</u>
35	P-1540	<u>CHAIN LINK</u>
35A	P-36970	<u>ANCHOR</u> - ATTACHES TO TOP OF SUPPORT TABLE ASSEMBLY. ITEM #6, THIS PAGE.
36	OBSOLETE	<u>GUARD</u> - THIS PART IS NO LONGER AVAILABLE.
37	P-487	<u>NUT</u> - CAP NUT IS NOT NEEDED DUE TO COVER.
38	P-1590	<u>REAMER</u>
39	P-1546	<u>REAMER TOOL</u>

**DRAWING #59A**  
**TABLE RAISE SHAFT, CHAIN GUIDES & DOLLY BOARD SUPPORTS**  
**9800 CAST FRAMES & 9800, 1-1**

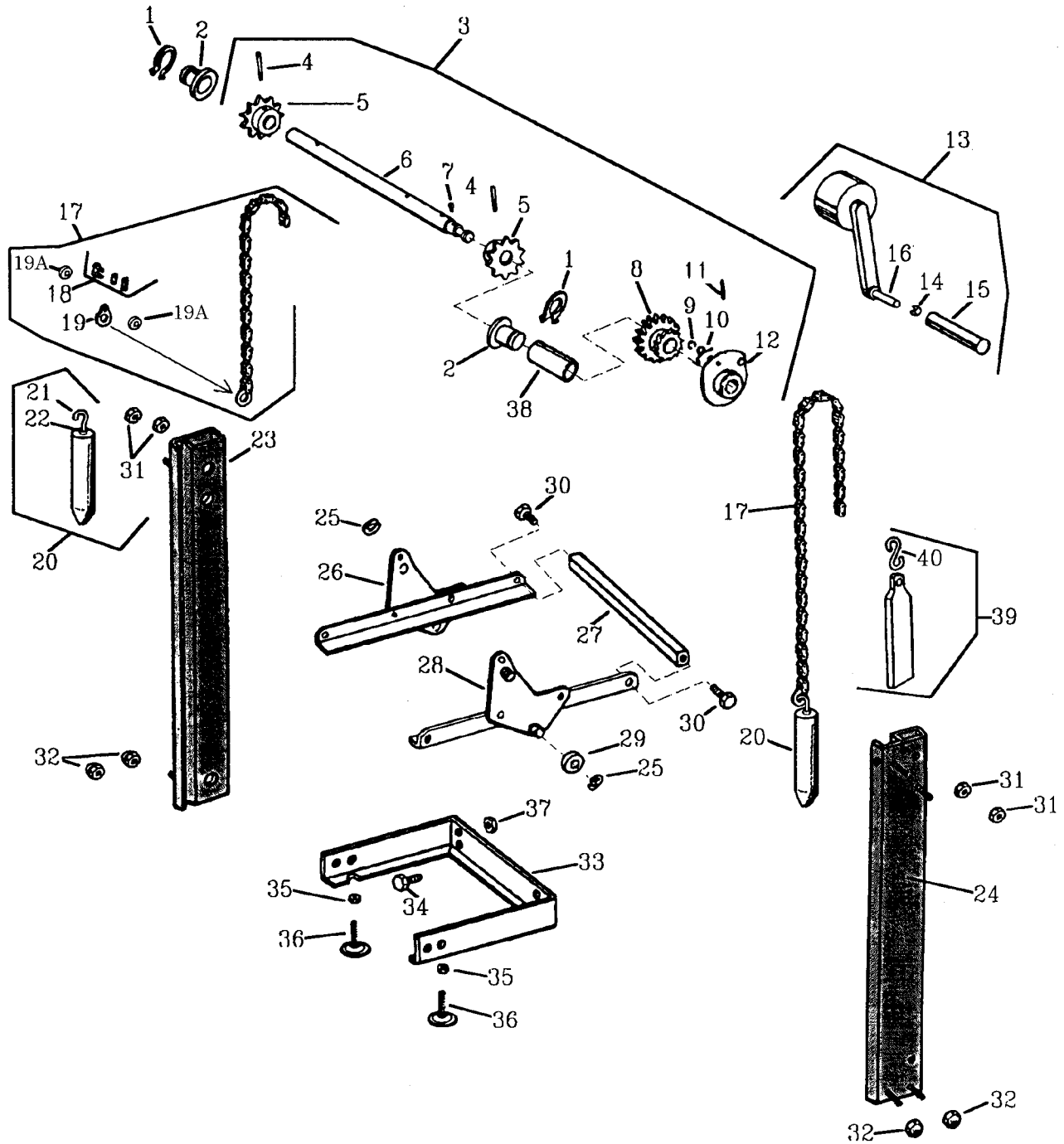



## TABLE RAISE SHAFT, CHAIN GUIDES &amp; DOLLY BOARD SUPPORTS - 9800CAST FRAMES &amp; 9800, 1-1

KEY #	PART#	DESCRIPTION
1	P-687	<u>RETAINING RING</u>
2	P-5810	<u>BUSHING</u>
3	P-982470	<u>SHAFT ASSEMBLY</u> - FITS THROUGH SIDE FRAME. SEE ITEM #21, PAGE 61. (FOR OTHER THAN 9800, 1-1 CHAIN DELIVERY)
	P-984210	<u>SHAFT ASSEMBLY</u> - FITS THROUGH SIDE FRAME. SEE ITEM #21, PAGE 61. (FOR 9800, 1-1 CHAIN DELIVERY ONLY)
4	P-433	<u>TAPER PIN</u>
5	P-362490	<u>SPROCKET</u>
6	NO #	<u>SHAFT</u> - NOT AVAILABLE SEPARATELY. MUST BUY FULL ASSEMBLY ITEMS #3, P-982470 OR P-984210.
7	P-363	<u>PIN</u> - COMES WITH SHAFT ASSEMBLY, ITEM #3, P-984210, 9800 1-1.
(*)	P-7002	<u>PIN</u> - USE ON P-982470 SHAFT ASSEMBLY ONLY FOR 9800, 1-1. (* ) DOES NOT COME WITH ASSEMBLY P-982470 ITEM #3 THIS PAGE.
8	P-982530	<u>GEAR</u> - OPERATED BY ITEM #23, PAGE 58A. (9800, 1-1 CHAIN DELIVERY ONLY)
	P-362530	<u>GEAR</u> - OPERATED BY ITEM #23, PAGE 58A. (FOR OTHER THAN 9800, 1-1 CHAIN DELIVERY)
9	P-666	<u>C-RING</u>
10	P-362570	<u>SPRING</u>
11	P-393	<u>ROLL PIN</u>
12	P-362590	<u>MOUNT</u> - NOT AVAILABLE SEPARATELY. MUST BUY FULL ASSEMBLY, ITEMS #3, P-982470 OR P-984210.
13	P-982630	<u>HAND CRANK ASSEMBLY</u> - COMPLETE. ATTACHES TO SHAFT, ITEM #6, THIS PAGE.
14	P-36959	<u>SPRING LOCK</u>
15	P-98961	<u>HANDLE</u>
16	P-36962	<u>HANDLE SHAFT</u>
17	P-36105	<u>CHAIN</u> - RIDES ON SPROCKET, ITEM #5, THIS PAGE.
18	P-1540	<u>CHAIN LINK</u>
19	P-36970	<u>CONNECTOR</u>
19A	P-561	<u>WASHER</u>
20	P-36106	<u>WEIGHT ASSEMBLY</u> - 350, 360, 375, 385 & 9800. NOT USED ON 9800 1-1 CHAIN DELIVERIES.
21	P-1038	<u>HOOK</u>
22	P-469	<u>NUT</u>
23	P-982090	<u>GUIDE</u> - NON-OPERATORS SIDE. MOUNTS TO INSIDE OF SIDE FRAME.
24	P-984220	<u>GUIDE</u> - OPERATORS SIDE. MOUNTS TO INSIDE OF SIDE FRAME.
25	P-668	<u>C-RING</u>
26	P-984230	<u>CARRIER FRAME</u> - NON-OPERATORS SIDE.
27	P-984240	<u>TIE BAR</u>
28	P-984250	<u>CARRIER FRAME</u> - OPERATORS SIDE.
29	P-5509	<u>CAM WHEEL</u> - RIDES INSIDE GUIDES, ITEMS #23 & #24, THIS PAGE.
30	P-943	<u>SCREW</u>
31	P-475	<u>KEPS NUT</u>
32	P-5377	<u>ACORN NUT</u>
33	P-982410	<u>SUPPORT TABLE YOKE</u> - ATTACHES TO SIDE FRAMES, ITEMS #26 & #27, THIS PAGE.
34	P-957	<u>SCREW</u>
35	P-506	<u>NUT</u>
36	P-98867	<u>GLIDER FOOT</u>
37	P-526	<u>NUT</u>
38	P-5512	<u>SPACER</u>
39	P-98106	<u>WEIGHT ASSEMBLY</u> - (9800, 1-1 ONLY)
40	NO #	<u>HOOK</u> - NOT AVAILABLE SEPARATELY AT THIS TIME.

**DRAWING #60**  
**SIDE FRAMES & BASE FRAME ASEMBLIES - (CHAIN DELIVERY)**

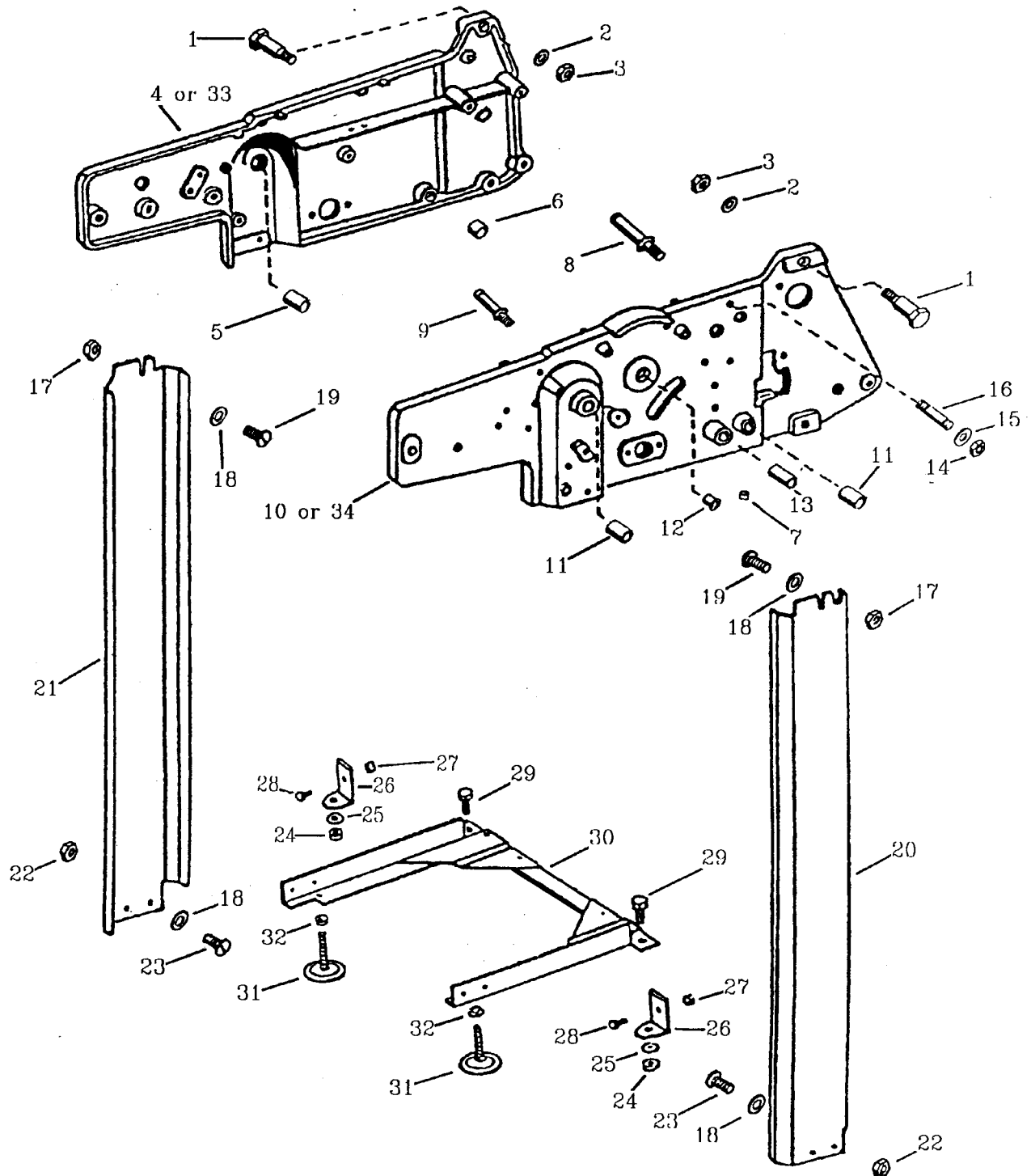

**PAGE #60**  
**SIDE FRAMES & BASE FRAME ASSEMBLIES - (CHAIN DELIVERY)**

KEY #	PART#	DESCRIPTION
1	P-8039	<u>SHOULDER SCREW</u> - SCREWS THROUGH FRAMES, ITEMS #4 & 10, THIS PAGE. ALSO SCREWS THROUGH SIDE FRAMES, ITEMS #20 & 22, PAGE 46.
2	P-610	<u>WASHER</u>
3	P-506	<u>NUT</u>
4	P-362670	<u>FRAME ASSEMBLY</u> - NON-OPERATORS SIDE. MOUNTS TO REAR SIDE FRAME, ITEM #22, PAGE 46 (SEE NOTE)
5	P-1264	<u>BUSHING</u>
6	P-1261	<u>BUSHING</u>
7	P-812	<u>BUSHING</u>
8	P-9044	<u>STUD</u>
9	P-6010	<u>STUD</u> - ITEM #27, PAGE 56, ATTACHES TO THIS STUD.
10	P-362850	<u>FRAME ASSEMBLY</u> - OPERATOR'S SIDE. MOUNTS TO REAR OF SIDE FRAME, ITEM #22, PAGE 46. (SEE NOTE)
11	P-1264	<u>BUSHING</u>
12	P-1313	<u>BUSHING</u>
13	P-1225	<u>BUSHING</u>
14	P-479	<u>NUT</u>
15	P-1614	<u>WASHER</u>
16	P-7009	<u>PIN</u>
17	P-281	<u>NUT</u>
18	P-574	<u>WASHER</u>
19	P-267	<u>SCREW</u>
20	P-362890	<u>GUARD</u> - OPERATOR'S SIDE. ATTACHES ONTO SIDE FRAME, ITEM #10, THIS PAGE.
21	P-362910	<u>GUARD</u> - NON-OPERATORS SIDE. ATTACHES ONTO SIDE FRAME, ITEM #4, THIS PAGE.
22	P-281	<u>NUT</u>
23	P-262	<u>SCREW</u>
24	P-512	<u>NUT</u>
25	P-649	<u>WASHER</u>
26	P-36871	<u>BRACKET</u>
27	P-506	<u>NUT</u>
28	P-338	<u>SCREW</u>
29	P-960	<u>SCREW</u>
30	P-362950	<u>FRAME ASSEMBLY</u> - ATTACHES TO #20 & 21, THIS PAGE, AND TO BOTTOM OF BASE FRAME, PAGE 49.
	P-372950	<u>FRAME ASSEMBLY</u> - ATTACHES TO #20 & 21, THIS PAGE, AND TO BOTTOM OF BASE FRAME, PAGE 49.
	P-382950	<u>FRAME ASSEMBLY</u> - ATTACHES TO #20 & 21, THIS PAGE, AND TO BOTTOM OF BASE FRAME, PAGE 49.
31	P-36867	<u>GLIDER FOOT</u>
32	P-500	<u>NUT</u>
33	P-982670	<u>FRAME</u> - NON-OPERATORS SIDE. MOUNTS TO REAR OF SIDE FRAME, ITEM #22, PAGE 46.
34	P-982850	<u>FRAME</u> - OPERATORS SIDE. MOUNTS TO REAR OF SIDE FRAME, ITEM #22, PAGE 46.
		 <b>NOTE:</b> THE OPERATORS AND NON-OPERATORS SIDE FRAMES ARE NOT SOLD SEPARATELY. MUST BUY COMPLETE CHAIN DELIVERY WITH STACKER. (PRESS SPECIALTIES STYLE CHAIN DELIVERY ONLY - 360 ONLY. SEE ITEMS #1, 2, & 3, PAGE 65).

**DRAWING #61**  
**PART LOCATION REFERENCES - (CHAIN DELIVERY)**

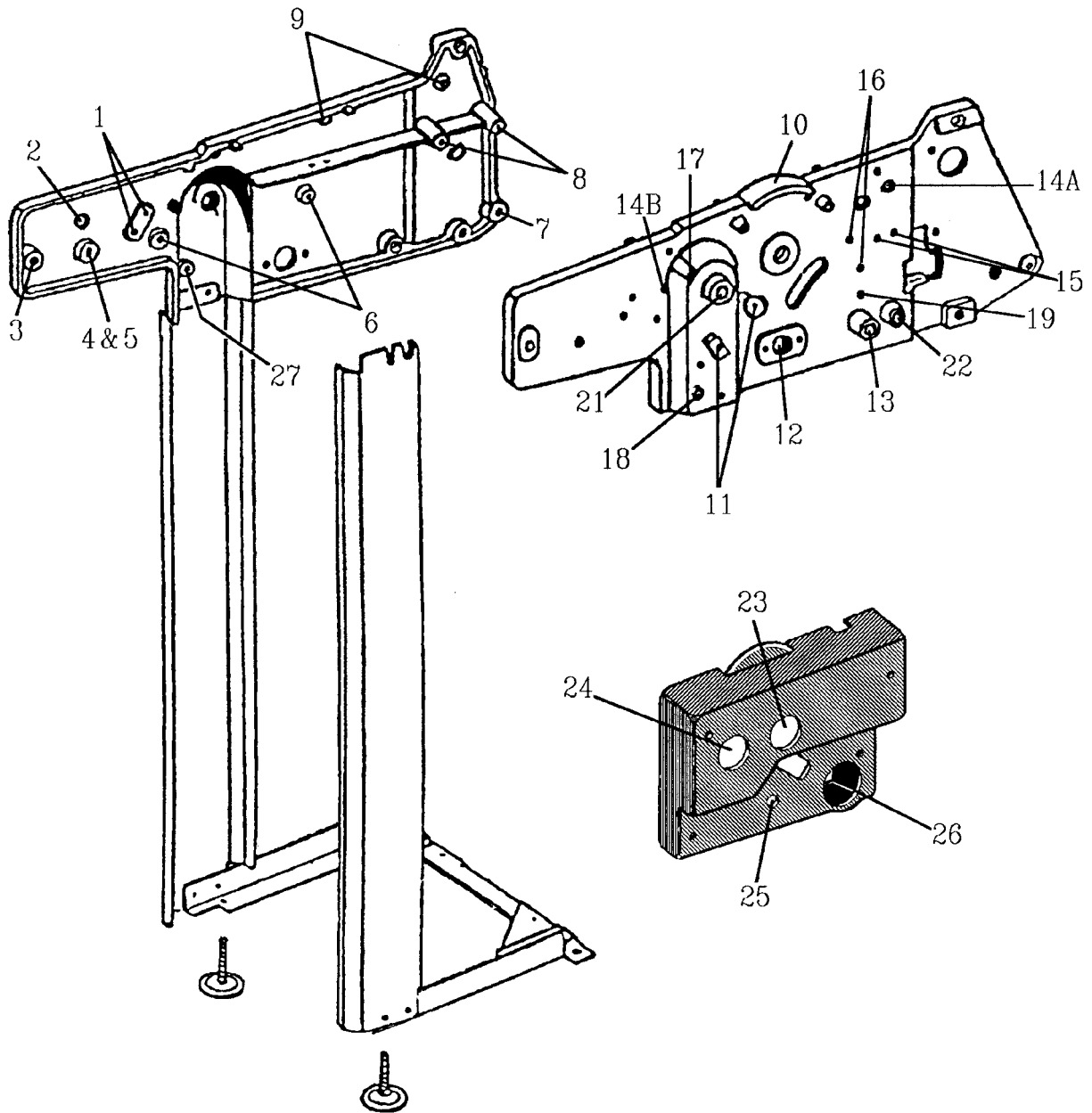

**PAGE #61**  
**PART LOCATION REFERENCES - (CHAIN DELIVERY)**

KEY #	PART#	DESCRIPTION
1	P-361460	<u>ADJUSTING BLOCK</u> - SEE ITEM #7, PAGE 55.
2	P-33	<u>ADJUSTING SET SCREW</u> - SEE ITEM #1, PAGE 55.
3	P-362220	<u>TIE BAR</u> - SEE ITEM #2, PAGE 62.
4	P-43	<u>SCREW</u> - SEE ITEM #11, PAGE 55.
	P-77	<u>SCREW</u> - SEE ITEM #11, PAGE 55.
5	P-361520	<u>NUT</u> - (NEW STYLE) SEE ITEM #12, PAGE 55.
	P-361130	<u>NUT</u> - (OLD STYLE) SEE ITEM #12, PAGE 55.
6	P-361250	<u>LOWER CHAIN SUPPORT</u> - (OLD STYLE) SEE ITEM #26, PAGE 54.
	P-361270	<u>LOWER CHAIN SUPPORT</u> - (NEW STYLE) SEE ITEM #26, PAGE 54.
7	P-361800	<u>TIE BAR</u> - SEE ITEM #10, PAGE 57.
8	P-361200	<u>SUPPORT ARM</u> - SEE ITEM #8, PAGE 53.
9	P-361150	<u>UPPER CHAIN SUPPORT</u> - (OLD STYLE) SEE ITEM #22, PAGE 5.
	P-361170	<u>UPPER CHAIN SUPPROT</u> - (NEW STYLE) SEE ITEM #22, PAGE 54.
10	P-362030	<u>CONTROL INDICATOR PLATE</u> - SEE ITEM #10, PAGE 58.
11	P-362350	<u>SUPPORT</u> - (350, 360, 375) SEE ITEM #34, PAGE 58.
	P-982350	<u>SUPPORT</u> - (9800) SEE ITEM #29, PAGE 58A.
12	P-362100	<u>CRANK SHAFT HOUSING</u> - SEE ITEM #36, PAGE 57.
13	P-361710	<u>SHAFT</u> - SEE ITEM #22, PAGE 56.
14A	P-7007	<u>MOUNTING STUD</u> - SEE ITEM #36, PAGE 63.
14B	P-7007	<u>MOUNTING STUD</u> - SEE ITEM 14, PAGE 55.
15	P-362880	<u>BRACKET</u> - (FOR PUSH BUTTON SWITCH) SEE ITEM #16, PAGE 63.
16	P-362900	<u>BRACKET</u> - (FOR MICRO SWITCH) SEE ITEM #16, PAGE 63.
17	P-7005	<u>MOUNTING STUD</u> - SEE ITEM #34, PAGE 63.
18	P-7008	<u>MOUNTING STUD</u> - SEE ITEM #37, PAGE 63.
19	P-7006	<u>MOUNTING STUD</u> - SEE ITEM #35, PAGE 63.
20	P-362230	<u>SHAFT</u> - SEE ITEM #24, PAGE 58.
21	P-362470	<u>SHAFT ASSEMBLY</u> - SEE ITEM #11, PAGE 59.
	P-982470	<u>SHAFT ASSEMBLY</u> - SEE ITEM #3, PAGE 59A.
	P-984210	<u>SHAFT ASSEMBLY</u> - SEE ITEM #3, PAGE 59A.
22	P-361920	<u>SHAFT &amp; GEAR ASSEMBLY</u> - SEE ITEM #17, PAGE 57.
23	P-362630	<u>HAND CRANK</u> - (USED FOR RECEDING PILE CONTROL) SEE ITEM #22, PAGE 59. / SAME HANDLE IS USED IN 2 PLACES.
24	P-362630	<u>HAND CRANK</u> - (USED FOR STACKER RAISE & LOWER) SEE ITEM #22, PAGE 59. / SAME HANDLE IS USED IN 2 PLACES.
25	P-36060	<u>HAND CRANK</u> - (USED FOR JOGGER ADJUSTMENT) SEE ITEM #30, PAGE 57. / SAME HANDLE IS USED FOR SPEED ADJUSTMENT (SEE ITEM #38, PAGE 1)
26	P-361650	<u>ADJUSTING KNOB</u> - SEE ITEM #19, PAGE 56.
27	P-362090	<u>GUIDE</u> - SEE ITEM #1, PAGE 59.

**DRAWING #62**  
**DOLLY BOARD & BACKSTOP ASSEMBLY**

NON-OPERATORS SIDE

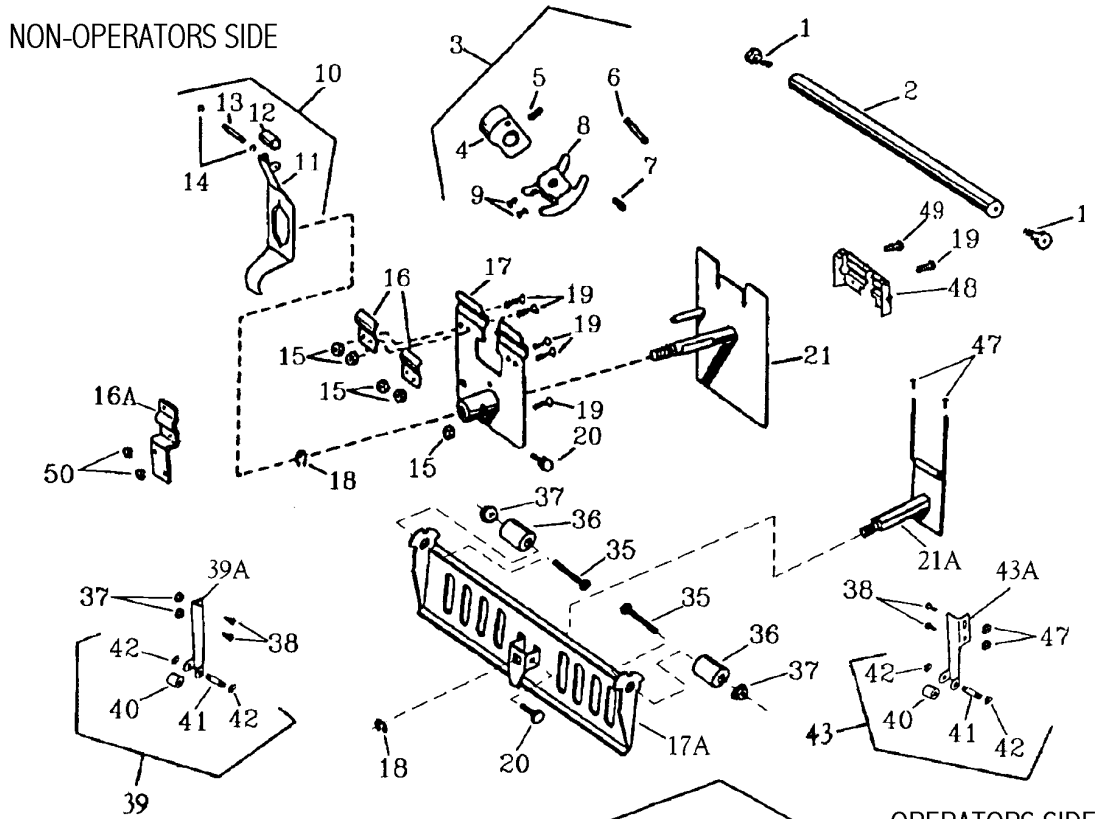

OPERATORS SIDE

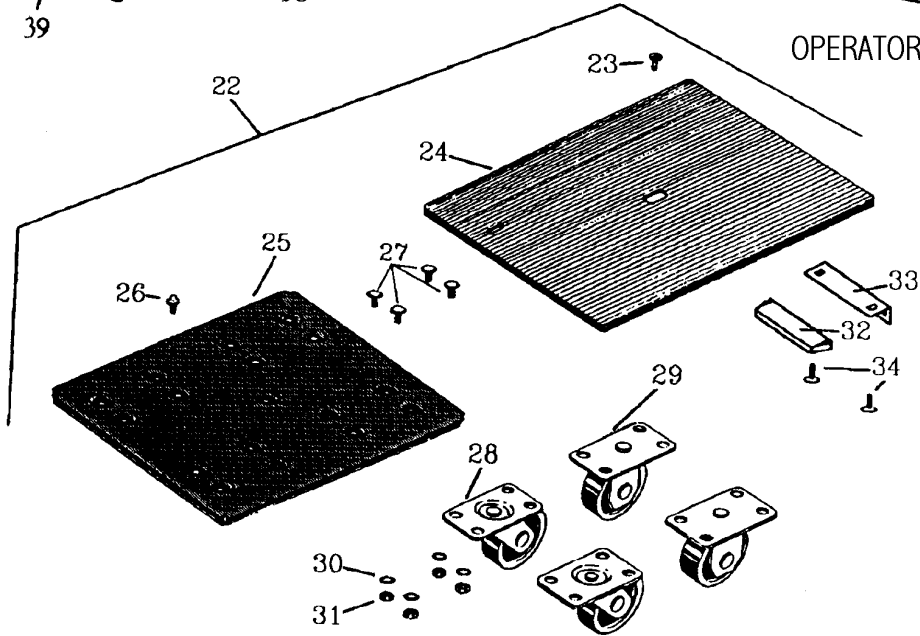

**PAGE #62**  
**DOLLY BOARD & BACKSTOP ASSEMBLY**

KEY #	PART#	DESCRIPTION
1	P-896	<u>SCREW</u>
2	P-362220	<u>TIE BAR</u> - BACK STOP SUPPORT. ATTACHES TO SIDE FRAMES, SEE ITEM #3 DRAWING 61.
	P-372220	<u>TIE BAR</u> - BACK STOP SUPPORT. ATTACHES TO SIDE FRAMES, SEE ITEM #3 DRAWING 61.
3	P-362240	<u>CAM ASSEMBLY</u> - 350, 360 & 385. LOCKS BACK STOP ASSEMBLY. SLIDES ONTO TIE BAR ITEM #2 THIS PAGE.
	P-372240	<u>CAM ASSEMBLY</u> - 375 & 9800. LOCKS BACKSTOP ASSEMBLY. SLIDES ONTO TIE BAR ITEM #2 THIS PAGE.
4	P-362260	<u>COLLAR</u> - OPERATES ITEM #10 THIS PAGE. 350, 360 & 385 ONLY. COMES WITH P-414 PIN ITEM #6.
	P-372260	<u>COLLAR</u> - 375 & 9800 ONLY.
5	P-29	<u>SET SCREW</u>
6	P-414	<u>ROLL PIN</u> - NOT USED ON 375. USED ONLY ON 350, 360 & 385.
7	P-25	<u>SET SCREW</u> - NOT USED ON 350, 360 OR 385. USED ONLY ON 375.
8	P-362280	<u>PAPER STOP</u>
9	P-543	<u>SCREW</u>
10	P-362300	<u>SPRING ASSEMBLY</u> - OPERATED BY ITEM #4 THIS PAGE.
	P-982300	<u>SPRING ASSEMBLY</u> - OPERATED BY ITEM #4 THIS PAGE.
11	P-362320	<u>SPRING</u>
	P-982320	<u>SPRING</u>
12	P-1521	<u>CAM ROLLER</u> - RIDES ON ITEM #4 THIS PAGE.
13	P-3002	<u>PIN</u>
14	P-679	<u>C-RING</u>
15	P-462	<u>NUT</u>
16	P-362380	<u>RETAINER</u> - 350, 360 & 385.
	P-372380	<u>RETAINER</u> - 375.
16A	P-982380	<u>RETAINER</u> - 9800.
17	P-362400	<u>BACKSTOP MOUNTING PLATE</u> - 350 & 360. ATTACHES TO TIE BAR ITEM #2 THIS PAGE.
	P-372400	<u>BACKSTOP MOUNTING PLATE</u> - 375. ATTACHES TO TIE BAR ITEM #2 THIS PAGE.
	P-982400	<u>BACKSTOP MOUNTING PLATE</u> - 9800 - NOT SHOWN. ATTACHES TO TIE BAR ITEM #2 THIS PAGE.
	P-382400	<u>BACKSTOP MOUNTING PLATE</u> - 385. ATTACHES TO TIE BAR ITEM #2 THIS PAGE.
17A	P-984270	<u>BACKSTOP MOUNTING PLATE</u> - 9800, 1-1. ATTACHES TO TIE BAR ITEM #2 THIS PAGE.
18	P-672	<u>C-RING</u>
	P-670	<u>C-RING</u> - 9800, 1-1 ONLY.
19	P-118	<u>SCREW</u>
20	P-312	<u>THUMB SCREW</u>
	P-5356	<u>THUMB SCREW</u> - 9800, 1-1 ONLY.
21	P-362420	<u>BACK STOP PLATE</u> - 350, 360, 375 & 9800.
	P-984320	<u>BACK STOP MOUNTING PLATE</u> - 9800, 1-1.
	P-382420	<u>BACK STOP PLATE</u> - 385.
21A	P-982420	<u>BACK STOP PLATE</u> - 9800, 1-1 (WITH STEEL PLATES).
22	P-362440	<u>DOLLY ASSEMBLY</u> - 350 & 360. RESTS ON SUPPORT, ITEM #6 PAGE 59.
	P-882440	<u>DOLLY ASSEMBLY</u> - 8815 - 8850.
	P-372440	<u>DOLLY ASSEMBLY</u> - 375 & 9800 STANDARD. RESTS ON SUPPORT, ITEM #6 PAGE 59.
	P-982440	<u>DOLLY ASSEMBLY</u> - 9800, 1-1. RESTS ON SUPPORT, ITEM #6 PAGE 59.
	P-382440	<u>DOLLY ASSEMBLY</u> - 385. RESTS ON SUPPORT, ITEM #6 PAGE 59.
23	P-1541	<u>POSITION SCREW</u>
24	P-362480	<u>DOLLY BOARD</u> - 350 & 360.
	P-382480	<u>DOLLY BOARD</u> - 385.
25	P-362500	<u>DOLLY FRAME</u> - BASE PLATE, STEEL.
	P-372500	<u>DOLLY BASE</u> - WOOD. 375 ONLY (NOT SHOWN).
	P-382500	<u>DOLLY BASE</u> - 385.
	P-982500	<u>DOLLY BASE</u> - WOOD. 9800 ONLY (NOT SHOWN).
26	P-7004	<u>DOWEL SCREW</u>
27	P-1558	<u>SCREW</u>
	P-1034	<u>SCREW</u> - FOR WOOD BASE, ITEM #25 - 375 & 9800 ONLY. SCREWS IN FROM BOTTOM.
28	P-1641	<u>CASTER</u> - SWIVEL, 2 PER ASSEMBLY.
29	P-1647	<u>CASTER</u> - RIGID, 2 PER ASSEMBLY.
30	P-647	<u>LOCKWASHER</u> - 350, 360 & 385 ONLY.
31	P-492	<u>NUT</u> - 350, 360 & 385 ONLY.
32	P-1674	<u>MAGNET</u> - CATCH. 375 & 9800 ONLY.
33	P-1673	<u>BRACKET</u> - FOR MAGNET ON 375 & 9800 ONLY.
34	P-1035	<u>SCREW</u>
35	P-85	<u>SCREW</u>
36	P-5513	<u>GUARD STOP</u> - MOUNTS TO INSIDE OF SIDE FRAMES ABOVE TIE BAR, ITEM #4 PAGE 57A.
37	P-472	<u>NUT</u>
38	P-5353	<u>SCREW</u>
39	P-984279	<u>ARM ASSEMBLY</u> - 9800, 1-1 ONLY. NON-OPERATORS SIDE.
39A	P-984280	<u>ARM</u> - 9800, 1-1 ONLY. NON-OPERATORS SIDE.
40	P-1475	<u>CAM ROLLER</u>
41	P-3012	<u>PIN</u>
42	P-679	<u>C-RING</u>
43	P-984289	<u>ARM ASSEMBLY</u> - 9800, 1-1 ONLY. OPERATORS SIDE.
43A	P-984290	<u>ARM</u> - 9800, 1-1 ONLY. OPERATORS SIDE.
44	P-984300	<u>REAR GUARD</u> - NOT SHOWN. ITEM #17 THIS PAGE MOUNTS TO THIS GUARD.
45	P-469	<u>NUT</u> - NOT SHOWN. FOR ITEM #46 THIS PAGE. (NEED 4).
46	P-5815	<u>BUSHING</u> - NOT SHOWN. GOES THROUGH SIDE FRAME ON REAR OF CHAIN DELIVERY. (NEED 4).
47	P-984310	<u>BUMPER</u>
48	P-984260	<u>BACK STOP PLATE</u>
49	P-245	<u>SCREW</u>
50	P-462	<u>NUT</u>

**DRAWING #63**  
**SAFETY GUARDS, COVERS & SAFETY SWITCHES - (CHAIN DELIVERY)**

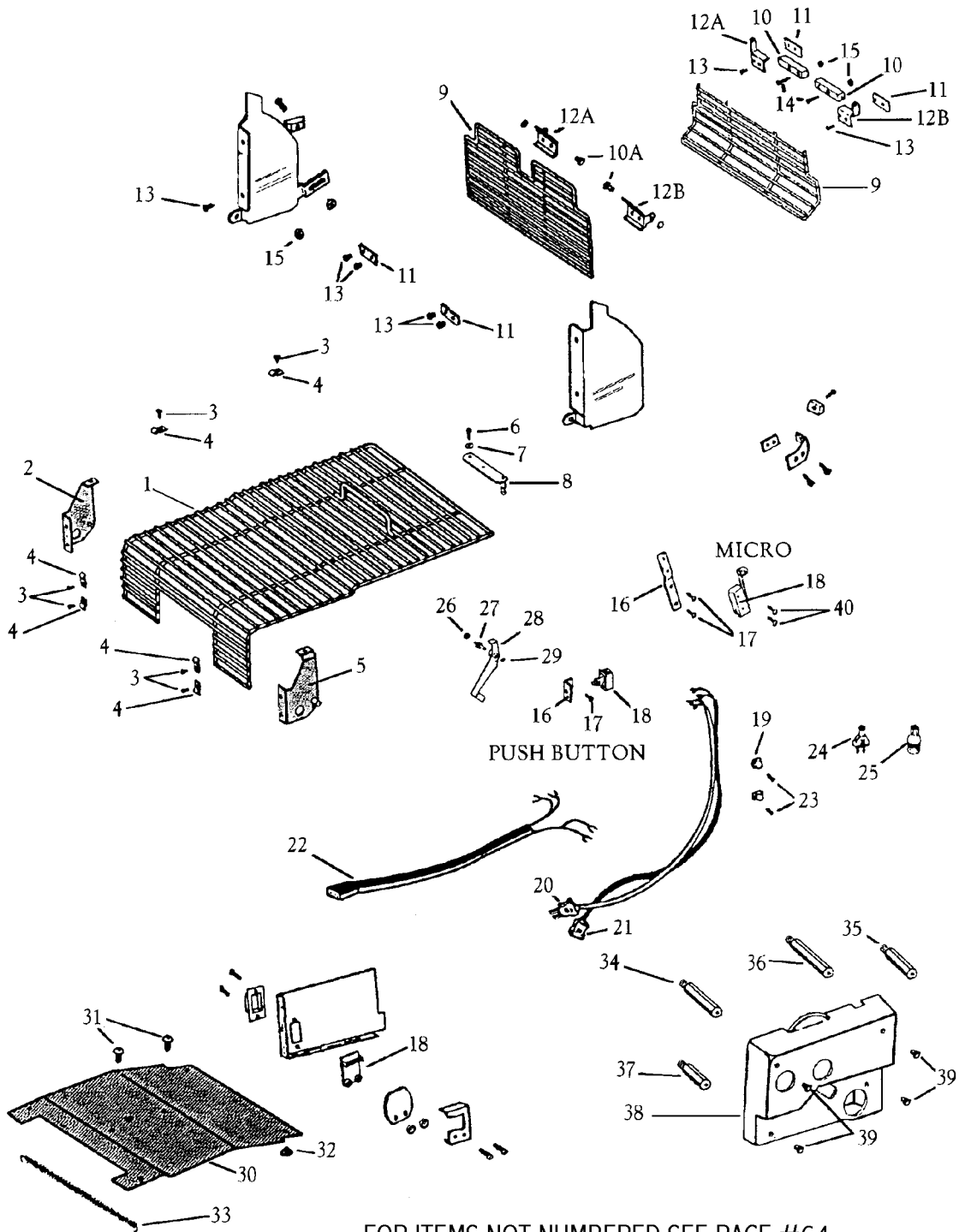

FOR ITEMS NOT NUMBERED SEE PAGE #64



## SAFETY GUARDS, COVERS &amp; SAFETY SWITCHES - (CHAIN DELIVERY) ...CONT. ON NEXT PAGE

KEY #	PART#	DESCRIPTION
1	P-362600	<u>SAFETY SCREEN</u> - 350, 360.
	P-372600	<u>SAFETY SCREEN</u> - 375, 9800.
	P-382600	<u>SAFETY SCREEN</u> - 385.
2	P-362620	<u>HINGE</u> - L.H. THREAD. SLIDES ONTO TIE BAR #P-362220, ITEM #2, PAGE 62.
3	P-257	<u>SCREW</u>
4	P-362640	<u>CLIP</u> - 350, 360.
	P-372640	<u>CLIP</u> - 375, 9800.
5	P-362660	<u>HINGE</u> - R.H. THREAD. SLIDES ONTO TIE BAR #P-362220, ITEM #2, PAGE 62.
6	P-260	<u>SCREW</u>
7	P-569	<u>WASHER</u>
8	P-362680	<u>SWITCH ACTIVATOR</u> - OLD STYLE FOR PUSH BUTTON SWITCHES.
	P-362700	<u>SWITCH ACTIVATOR</u> - NEW STYLE FOR MICRO SNAP SWITCHES.
9	P-362720	<u>SAFETY SCREEN</u> - 350, 360 OLDSTYLE
	P-362740	<u>SAFETY SCREEN</u> - 350, 360 NEW STYLE.
	P-372740	<u>SAFETY SCREEN</u> - 375, 9800.
	P-382740	<u>SAFETY SCREEN</u> - 385.
10	P-8015	<u>SHOULDER SCREW</u> - FOR PRESSES WITH NEW STYLE TIE BAR.
	P-362760	<u>BLOCK</u> - 350, 360. ONLY FOR PRESSES WITH IOLD STYLE TIE BAR.
10A	P-9046	<u>STUD</u> - WORKS WITH P-372840, ITEM #12A, THIS PAGE.
11	P-362780	<u>PLATE</u> - 350, 360, & 385 NEW STYLE.
	P-362800	<u>PLATE</u> - 350, 360, & 385 OLD STYLE. USED WITH P-362840 HINGE, ITEM #12A, THIS PAGE.
	P-372800	<u>PLATE</u> - 375, 9800. USE WITH P-372840, ITEM #12A, THIS PAGE.
12A	P-362820	<u>HINGE</u> - L.H. OLD STYLE - FOR CAST TIE BAR. HAS 1" LONG CLIP FOR HINGE.
	P-362840	<u>HINGE</u> - 350, 360, & 385. LEFT HAND NEW STYLE. USED WITH P-362800. HAS 2-1/4" LONG CLIP.
	P-372840	<u>HINGE</u> -375 ONLY. SAME FOR LEFT AND RIGHT HAND.
12B	P-363230	<u>HINGE</u> - R.H. OLD STYLE. FOR CAST TIE BAR. HAS 1" LONG CLIP FOR HINGE.
	P-363250	<u>HINGE</u> - R.H. NEW STYLE. HAS 2-1/4" LONG CLIP FOR HINGE.
13	P-263	<u>SCREW</u>
	P-124	<u>SCREW</u> - USED WITH P-362800 & P-362840.
14	P-1829	<u>SCREW</u> - FOR BLOCK USED ON OLD STYLE HINGES ONLY.
15	P-471	<u>NUT</u>
16	P-362880	<u>MOUNTING BRACKET</u> - FOR PUSH BUTTON SWITCHES. MOUNTS TO SIDE FRAME. SEE #15, DRAWING 61.
	P-362900	<u>MOUNTING BRACKET</u> - FOR MICRO SNAP SWITCHES. MOUNTS TO SIDE FRAME. SEE #16, DRAWING 61.
17	P-273	<u>SCREW</u> - FOR OLD STYLE BRACKET.
	P-260	<u>SCREW</u> - FOR NEWS TYLE BRACKET.
18	P-362920	<u>SWITCH</u> - 350, 360, 385 PUSH BUTTON (OLD STYLE). OPERATED BY ITEM #28, THIS PAGE. (8 Amp, or 16 Amp, 125V/250Vac, 3/4 HP).
	P-362940	<u>SWITCH</u> - 350, 360, 385 MICRO SNAP SWITCH (NEW STYLE). OPERATED BY ITEM #8, THIS PAGE. (15 Amp, 125/250/480 Vac, 1/8 HP).
	P-372940	<u>SWITCH</u> - 375, 9800 (REED).
18A	P-382940	<u>SWITCH &amp; CORD</u> - NOT AVAILABLE AS AN ASSEMBLY. MUST BUY PARTS SEPARTAELY. (ITEMS #16, P-362900 / #17, P-260 / #18, P-362940 / #19, P-1840 / #22, P-1672)
19	P-1512	<u>CABLE CLAMP</u>
	P-1840	<u>CABLE CLAMP</u> - USE WITH P-194 SCREW, ITEM #23, THIS PAGE.
20	P-4008	<u>CORD</u> - USED WITH OLD STYLE PUSH BUTTON SWITCH.
21	P-4007	<u>CORD</u> - USED WITH OLD STYLE PUSH BUTTON SWITCH.
22	P-1672	<u>CORD</u> - USED WITH NEWSTYLE MICRO SNAP SWITCH.
	P-1675	<u>CORD</u> - USED WITH NEWSTYLE MICRO SNAP SWITCH #P-372940.
23	P-262	<u>SCREW</u>
	P-194	<u>SCREW</u> - USE WITH P-1840 CABLE, ITEM #19, THIS PAGE.
24	P-363040	<u>PLUG</u> - FOR MACHINES WITH BAKELITE PLUGS AND CONNECTORS.
25	P-363060	<u>CONNECTOR</u> - FOR MACHINES WITH BAKELITE PLUGS AND CONNECTORS.
26	P-487	<u>NUT</u>
27	P-363080	<u>STUD</u>
28	P-363100	<u>LATCH</u> - FOR OLD STYLE SWITCH ONLY. OPERATES SWITCH, ITEM #18, THIS PAGE.
29	P-669	<u>C-RING</u>
30	P-363120	<u>COVER</u> - MOUNTS ON TOP OF SUPPORT ASSEMBLY, ITEM #30, PAGE 56.
31	P-1026	<u>SCREW</u>
32	P-363140	<u>PLUG</u>
33	P-36554	<u>TINSEL</u> - 12 INCH LENGTH. TIES ONTO COVER, ITEM #30, THIS PAGE.
	P-36558	<u>TINSEL</u> - 10 FOOT LENGTH FOR EXTRA SUPPLY ON HAND.
34	P-7005	<u>STUD</u> - COVER MOUNT. MOUNTS TO SIDE FRAME WITH COVER, ITEM #17, DRAWING 61.
35	P-7006	<u>STUD</u> - COVER MOUNT. MOUNTS TO SIDE FRAME WITH COVER, ITEM #19, DRAWING 61.
36	P-7007	<u>STUD</u> - COVER MOUNT. MOUNTS TO SIDE FRAME WITH COVER, ITEM #14A, DRAWING 61.
37	P-7008	<u>STUD</u> - COVER MOUNT. MOUNTS TO SIDE FRAME WITH COVER, ITEM #18, DRAWING 61.
38	P-363240	<u>SIDE FRAME COVER</u> - 350, 360, 385 (BROWN)
39	P-170	<u>SCREW</u>
40	P-238	<u>SCREW</u> - FOR MICRO SNAP SWITCH.

**DRAWING #64**  
**SAFETY GUARDS, COVERS, & SAFETY SWITCHES - (CHAIN DELIVERY)**  
...CONTINUED FROM LAST PAGE

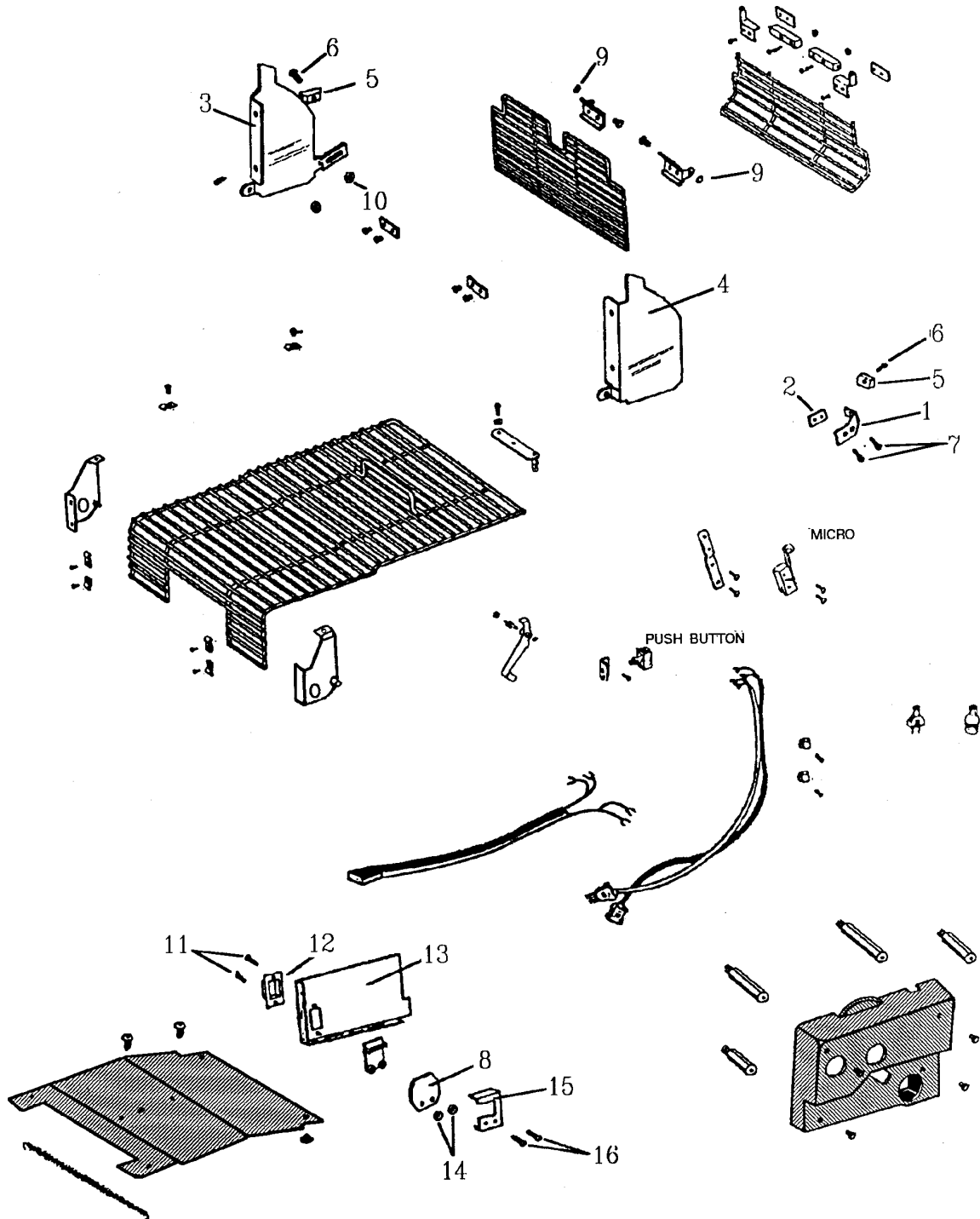

## SAFETY GUARDS, COVERS &amp; SAFETY SWITCHES - (CHAIN DELIVERY) ...CONT. FROM LAST PAGE

KEY #	PART#	DESCRIPTION
1	P-362540	<u>BRACKET</u> - 360PRO, 385
	P-372540	<u>BRACKET</u> - 375, 9800. FOR MAGNET, ITEM #5.
2	P-372650	<u>NUT PLATE</u> - 375, 9800. WORKS WITH P-372540, ITEM #1, THIS PAGE.
3	P-372560	<u>GUARD</u> - 375, 9800.
4	P-372580	<u>GUARD</u> - 375, 9800.
5	P-1676	<u>MAGNET</u> - FOR GUARDS, ITEMS #3 & 4, THIS PAGE.
6	P-983	<u>SCREW</u>
7	P-235	<u>SCREW</u>
8	P-372770	<u>SHIELD</u>
9	P-666	<u>C-RING</u>
10	P-461	<u>NUT</u>
11	P-836	<u>SCREW</u>
12	P-372490	<u>SAFETY SWITCH COVER</u>
13	P-372590	<u>COVER</u>
14	P-1398	<u>SPACER</u>
15	P-371460	<u>MOUNT</u>
16	P-245	<u>SCREW</u>

**DRAWING #65**

**COMPLETE CHAIN DELIVERY (PRESS SPECIALTIES)**

- 1. P-362850 CHAIN DELIVERY - (COMPLETE WITH STACKER)
- 2. P-362670 CHAIN DELIVERY - (CHAIN ONLY-NO STACKER)
- 3. P-362960 STACKER ONLY - (NO CHAIN)
- 4. P-5023 PULL ROD - FOR DOLLY BOARD. SEE PAGE 62.

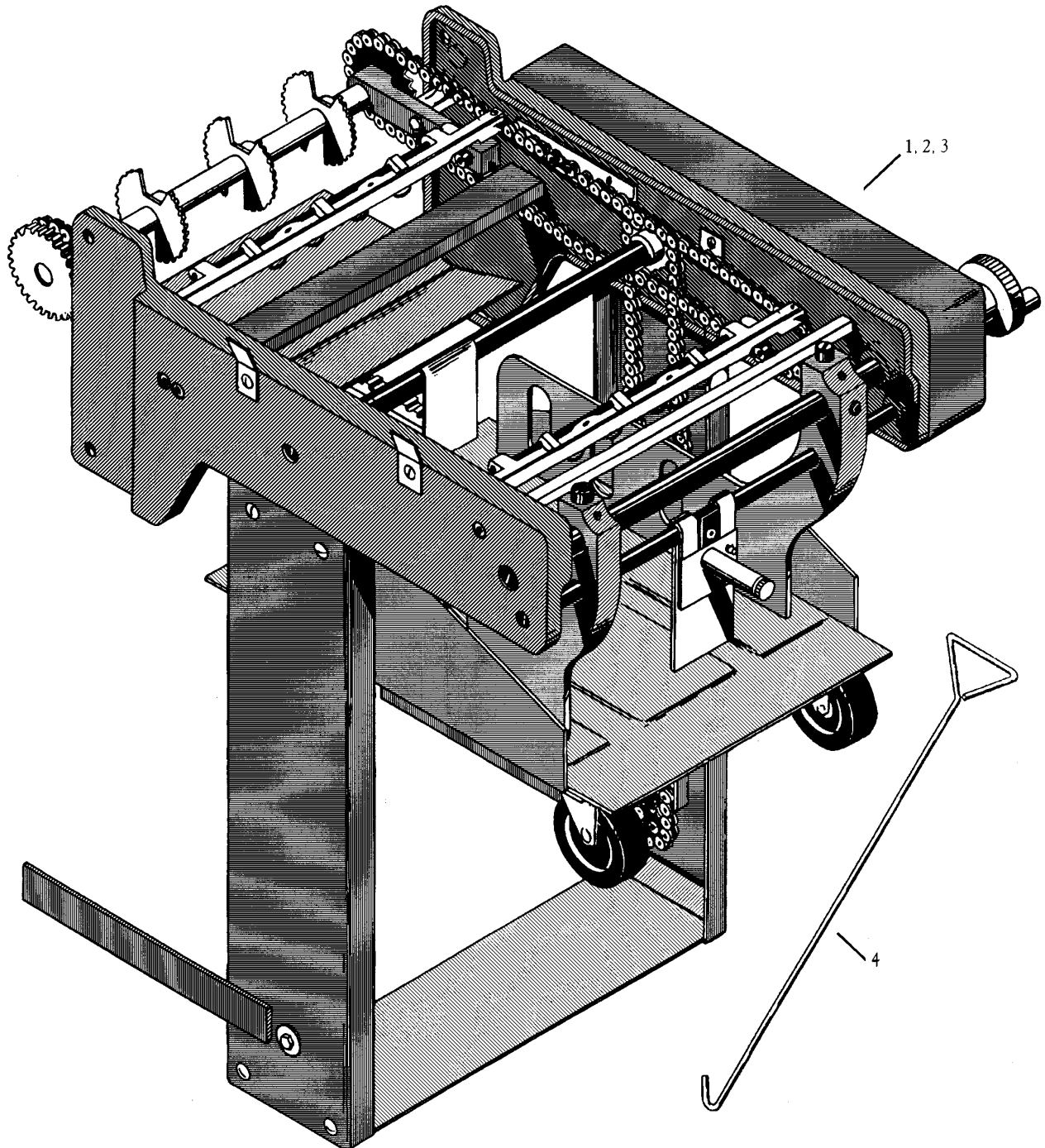



# I N D E X

PART NO.#	PAGE & INDEX KEY NO.#	PART NO.#	PAGE & INDEX KEY NO.#	PART NO.#	PAGE & INDEX KEY NO.#
P-4	12-40, 17A-31, 26-51	P-192	48-34	P-347	11-22
P-5	44-34	P-194	56A-5, 63-23	P-348	23-15
P-7	1B-21, 10-3, 53A-22	P-203	48A-9, 48C-26	P-349	11-4, 17-43, 22-44
	57-27	P-204	40-41, 48C-44, 51-8		40-13
P-8	9-41, 10-17, 15-11	P-205	47-12	P-350	6-3, 14-37, 17A-31A, 25-2
	18-11, 19-14, 19-33	P-207	18-23		29A-28
	23-45, 24A-8, 29C-59	P-215	37-49, 48C-43	P-354	37-44
	42-17, 55-19, 55A-25	P-220	31-17	P-355	34-8
P-9	1B-33, 1B-33	P-229	10-44, 47-27	P-356	8-6
P-10	1-39, 8-49, 22-48,	P-230	52-13	P-363	59A-7
	48-39, 55-34, 57-34	P-232	51-30	P-373	31-10
P-11	22-13, 23-14, 35-30	P-235	37-50, 42-6, 52-8	P-374	10-36
	52-6		56A-6, 64-7	P-379	4A-6, 22-22A, 23-12A
P-13	44-12	P-236	48A-36, 48B-19, 48C-9		35-37
P-18	9-22, 42-17	P-238	63-40	P-380	1A-9, 1B-3, 1-50, 8-27
P-20	1-34, 1A-52, 1B-43	P-239	58-9		10-6, 14-10, 22-2
P-25	19-17, 19-36, 26-24	P-242	51-26, 52-1		23-2, 26-12, 36-10
	26A-11, 29C-24, 42-8	P-244	17-38		36-30, 57-35
	62-7	P-245	5-13, 15-3, 58A-5	P-382	1-44, 1A-8, 18-27,
P-26	1A-41, 1-10, 44-26		62-49, 64-16		23-39, 32-29, 58-22
P-27	12A-36, 17A-44, 41-21	P-246	52-31C		58A-21
	42-45	P-248	22-16, 23-23, 48B-6	P-383	8-19, 22-36
P-29	17-7, 17A-47, 62-5	P-249	48-12	P-385	34-9
P-32	2-3	P-251	15-22	P-386	36-7, 36-28
P-33	55-1	P-253	17A-33	P-388	22-25, 23-10
P-37	17-8, 17A-13, 54-8	P-254	35-41, 59-8	P-392	9-25, 14-35, 34-8
P-43	7-10, 17A-18, 17A-32	P-256	7-31, 34-19	P-393	1-21, 1A-36, 34-9
	24B-16, 29C-28, 55-11	P-257	10-39, 17A-23, 29C-60		59-23, 59A-11
P-44	39-26, 10-27		42-4, 48A-7, 48C-40	P-399	7-43, 7A-9
P-47	12-45		63-3	P-401	34-7, 42-29, 54-11, 58-40
P-55	35-25, 25-39, 53-4	P-259	48B-16, 51-33		58A-25
	53A-28	P-260	10-14, 47-25, 56-35	P-403	34-7, 36-5, 41-5, 42-29
P-57	17-47, 40-32, 43-6		58-11, 63-6	P-406	42-29
P-64	15-45, 16-14, 17-23	P-261	6-15, 6-16	P-410	39-38
	17A-38	P-262	11-14, 29A-33, 29B-51	P-412	39-38
P-65	17A-49		29C-68, 41-18, 47A-6,	P-414	62-6
P-66	17A-46		48-, 48A-38, 57-40, 60-23,	P-421	10-3, 10-33, 12-38
P-67	12-11, 12A-19, 12A-40		63-23		15-33, 20-19
P-68	13-5, 12A-40, 13A-8	P-263	14-1, 14-22, 22-28	P-422	10-6
P-76	4-16		24B-9, 25-5, 29A-29	P-423	18-28
P-77	55-11		32-12, 32-20, 34-1	P-424	22-35, 23-44, 56A-28
P-80	48B-18		34-1, 44-1, 46-15	P-427	10-33, 28-22
P-81	12-6, 40-21, 48C-4		63-13	P-428	1-45, 35-38, 44-24
	51-40, 53A-31, 56A-33	P-264	14-31, 21-5, 35-32		29A-27
	57A-26		45-17	P-429	9-25, 29B-25, 29C-57
P-82	1B-10, 7A-27, 8-7	P-266	49-3, 57-7	P-431	8-21, 26-34, 58A-24
	9-19, 14-31, 29B-39	P-267	12-30, 32-9, 60-19	P-432	25-2
	29C-49, 53A-5, 60-35	P-268	12-33, 12A-2	P-433	9-28, 21-3, 59-12
	31-30, 45-28, 55A-2	P-271	20-24, 22-46, 37-12		59A-4
P-85	16-41, 17-12		45-8	P-434	1A-6, 1-45, 12A-10
P-86	38-66, 56-33	P-272	29C-46		44-14
P-91	1B-38, 7A-29, 56-33	P-273	46-30, 63-17	P-435	25-34A, 58-38
P-92	14-12	P-275	8-26, 13-17	P-436	1A-11, 1-56, 9-8
P-102	33-4, 33-36	P-277	19-2, 44-9, 45-16		28-14, 44-15, 25-34
P-105	33-9	P-278	38-20		56A-52
P-107	48-20, 48C-27	P-279	1-33	P-442	56-24, 57-20
P-111	48-5	P-281	59-4, 60-17, 60-22	P-443	1A-33, 1-17, 8-32
P-112	2-20, 56A-22	P-298	14-7		44-16
P-114	36-3	P-299	1-37, 8-47, 48-37	P-444	8-2
P-118	29B-52, 29C-69, 62-19		57-45	P-447	53A-16
P-124	13-24, 13A-24, 24A-2	P-300	14-45, 22-3, 23-6	P-453	53-6
	24B-10, 29C-45, 63-13		35-31, 29B-4, 29A-17	P-456	51-34, 52-12
P-125	54-30, 53A-13	P-302	24B-15	P-460	18-8A, 48A-34
P-131	3-1	P-312	62-20	P-461	48B-25, 48C-8
P-133	42-40	P-318	18-6, 59-23	P-462	5-10, 10-50, 46-29,
P-151	47-29	P-319	11-7, 32-6		47-14, 48-13, 52-31D,
P-155	18-8	P-338	49-15, 60-28		62-15, 62-50
P-170	63-39	P-339	6-7	P-464	35-22
P-172	29A-29	P-340	1-15, 1A-44	P-466	48-1
P-173	12-19, 40-27	P-342	31-5	P-469	26-9, 26-37, 33-26, 35-8,
P-189	48-33	P-346	28-2		36-14, 37-17, 48A-21,

# I N D E X

PART NO.#	PAGE & INDEX KEY NO.#	PART NO.#	PAGE & INDEX KEY NO.#	PART NO.#	PAGE & INDEX KEY NO.#
P-469	48B-24, 48-4, 49-4, 58A-4,	P-551	14-17	P-657	19-22
P-471	59-32, 59A-22	P-552	42-1	P-658	19-30
	5-9, 5-21, 6-12	P-559	33-30	P-661	23-34, 33-31
	6-15, 8-8, 12-42	P-562	48A-35	P-664	15-27, 16-43
	12A-17, 14-3, 14-23	P-564	5-11	P-666	12A-15, 12A-29, 15-15
	17-31, 20-1, 21-8	P-565	5-12		16-21, 17-35
	22-30, 24B-7, 25-8	P-566	37-4		17A-17, 37-53, 38-27
	29A-19, 29B-14, 29B-43	P-567	51-10	P-667	54-10, 59-17, 59A-9, 64-9
	29C-53, 31-20, 32-8	P-569	1A-43, 1-13, 16-20		6-9, 18-21, 29C-13
	33-22, 34-30, 34-30		26-38, 34-20, 36-15		34-13
	35-16, 35-35, 36-23		48C-14, 63-7	P-668	13-30, 15-8, 15-18
	37-11, 38-14	P-570	31-39, 33-25		16-27, 17A-5, 31-9
	40-1, 43-11, 44-2	P-577	6-8, 29C-17, 34-14		37-15, 42-13, 53-25
	45-12, 46-34, 48C-3	P-582	45-15		54-13, 56-16, 56-38
	51-6, 51-28, 52-26	P-583	12-14, 15-13, 35-24	P-669	57A-19, 59-10, 59A-25
	56A-31, 63-15		43-5, 48-21		7-30, 12-27, 12A-24, 16-3
P-472	1B-11, 9-20, 14-47	P-586	5-25, 16-25, 17A-6		17-33, 26A-20, 34-18
	28-30, 31-38, 40-40		28-25, 33-16, 43-14		37-21, 38-45, 38-52
	49-4, 53A-4, 56A-19	P-590	44-10, 53-25, 53A-26		39-4, 47-38, 17A-11
	57A-28, 62-37	P-592	17A-28, 31-22		52-14, 56-5, 56A-53
P-473	8-15, 28-30	P-595	38-46, 47-39, 47-46		58-20, 58A-19, 63-29
P-474	38-9A		56-11	P-670	1B-4, 1B-35, 10-18
P-475	59A-31	P-596	35-18, 38-50, 43-20		11-10, 19-13, 20-35
P-478	21-19, 26-18, 33-37		56-18, 56A-44		28-37, 38-40, 39-56
P-479	19-5, 60-14	P-597	1-2, 49-13		40-11, 43-22, 45-11
P-486	12-16, 13-27, 16-37	P-598	1A-30, 1-6, 5-15,		56-14, 57A-14, 62-18
	17-14, 20-25, 43-2		19-20, 31-27, 37-30	P-672	1A-17, 1-51, 1-60,
P-487	1A-19, 1B-23, 1B-41		38-51, 56-6		20-16, 22-42, 28-17
	5-21, 6-6, 6-14, 7-7	P-601	46-11, 49-14, 57A-12		29A-8, 29B-12, 29C-22
	7-39, 7A-4, 7A-24,		58-29		39-60, 42-21, 55A-17
	8-25, 9-7, 19-12	P-602	5-5, 56-15, 57-38		57A-21, 62-18
	20-33, 21-8, 22-15		58A-10	P-673	38-65, 44-6, 56A-46
	23-19, 23-28, 26-43	P-603	14-41, 33-13, 38-2		57-24
	26A-16, 28-3, 29A-23	P-604	1B-36, 6-10, 11-28	P-674	1A-28, 1-4
	29B-23, 31-26, 35-10		32-22, 40-10, 43-23	P-679	62-14, 62-45
	36-12, 38-23, 39-8		54-36	P-682	26-49, 48-7
	40-4, 43-17, 46-3	P-610	1B-40, 13A-14, 60-2	P-684	17-10, 56A-14
	47-44, 48C-24, 49-23	P-611	12A-21, 24B-27, 35-2	P-685	34-32
	50-5, 52-18, 59-37		38-4, 38-25	P-686	18-13
	63-26	P-613	1B-28, 6-25, 23-31	P-687	23-32, 56A-12, 56A-30
P-489	40-37, 45-6		25-32, 34-38, 39-52		57A-16, 59A-1
P-492	2-17, 41-11, 42-37	P-614	32-18, 57A-22	P-689	37-34
	55-2, 55A-4, 62-31	P-615	58-32	P-690	17-19
P-496	1-24, 1A-46, 42-24	P-617	19-29, 29C-21, 29C-44	P-691	14-30, 15-43, 16-12
P-497	1-24, 1A-46, 38-37,	P-620	24B-5, 45-30		17-20
P-500	32-13, 49-20, 60-32	P-621	4A-20, 38-64, 45-32	P-692	12-8, 12A-41, 14-19
P-505	24B-17, 45-31		53A-20, 55-22, 55A-9	P-693	26-26, 26A-13
	49-18		55A-21	P-694	17A-40, 12A-48
P-506	35-45, 39-24, 39-47	P-622	3-42	P-696	1-14
	41-7, 42-35, 46-10, 49-20A	P-625	37-18	P-698	5-24, 6-6, 17-6
	58-28, 59A-35, 60-3	P-627	53-3, 53A-27		28-24, 33-17, 39-14
	60-27	P-628	1A-47, 1-25		56-23, 56A-37, 58-6
P-507	6-17, 25-27, 41-16	P-629	39-46, 41-8, 42-34	P-699	35-17, 38-49, 43-19
	39-51		53-17	P-700	1A-39, 1-11, 5-16,
P-508	40-46	P-632	35-21, 48-10		10-28, 19-7, 29C-8
P-509	25-28	P-633	20-11		35-39, 40-23, 29A-7
P-510	20-4	P-634	32-14, 35-46, 39-23		29B-8, 53A-29, 54-2
P-512	60-24	P-635	7-4, 12-15, 16-38	P-703	1A-25, 1-23, 5-4
P-514	1B-25, 4-9, 34-39, 49-20B		17-13, 21-11, 25-20		6-21, 9-37, 11-27
P-517	22-12, 22-20, 56A-42		26-2, 33-38, 40-33		14-42, 28-28, 32-21
P-521	13-2, 26-36, 36-14		43-3		33-12, 35-11, 35-49
P-524	41-13, 42-38		20-5, 46-26		38-1, 39-55, 58-7
P-525	46-36	P-639	53-29		54-37, 58A-9
P-526	1A-29, 1-5, 1B-17	P-640	47-36, 52-30	P-704	12A-5, 35-1, 38-3
	22-26, 23-7, 59A-37	P-641	16-8, 59-3	P-705	8-29, 19-25A, 21-17,
P-530	47-3, 48-18, 49-1	P-646	46-2		24A-10, 25-33, 32-19,
P-532	48A-39	P-647	14-13, 37-10, 45-4		37-26, 39-17
P-541	33-2		46-2, 62-30	P-706	19-31
P-542	49-3	P-649	4-10, 46-24, 60-25	P-707	1B-45, 1B-45, 53A-19
P-543	48-26, 62-9	P-654	15-19, 53-24	P-709	42-46, 53-11
P-546	18-4	P-655	17A-7	P-710	1A-53, 1B-44, 1-33

# I N D E X

PART NO.#	PAGE & INDEX KEY NO.#	PART NO.#	PAGE & INDEX KEY NO.#	PART NO.#	PAGE & INDEX KEY NO.#
P-711	3-37, 8-42, 29A-4, 29B-17 29C-4, 55A-13, 57A-29	P-953	41-12, 42-36	P-1163	3-12, 4-21
P-716	31-44	P-954	55-8, 55A-1	P-1165	3-27, 3-29
P-717	11-24	P-956	1B-16	P-1166	3-2, 3-29
P-722	11-23	P-957	1-1, 1B-27, 8-40	P-1167	3-4
P-726	56-8		18-31, 19-1, 49-12	P-1170	3-11
P-729	39-17A		53A-1, 59A-34	P-1171	2-2
P-739	1A-7, 1-46, 23-40	P-958	3-16, 41-9, 42-33	P-1172	4-19
P-742	22-8, 23-22	P-960	60-29	P-1174	3-14, 4-22
P-743	9-21, 42-16	P-964	47-2, 47A-5	P-1177	4-12
P-746	18-10, 19-8	P-966	47-17, 48-28, 48-34	P-1179	4-4, 4-14, 4A-15
P-747	23-43		48C-47	P-1180	4-5, 4A-16, 5-23
P-749	9-32	P-967	52-4	P-1181	4-13
P-756	26-22, 26A-9	P-969	35-29	P-1182	3-29
P-764	11-6	P-973	48A-41, 49-24	P-1184	4-24
P-765	32-7, 37-19	P-974	47-17	P-1186	3-26
P-767	28-33	P-975	54-25	P-1187	4-7
P-773	31-21	P-984	7-13, 7A-25	P-1188	5-1
P-777	11-20	P-987	4A-10	P-1189	4-1
P-780	58-31	P-989	48A-18	P-1190	1-28, 2-9
P-783	34-41	P-993	29A-2, 29B-6, 38-32, 51-4, 51-21, 58-15	P-1194	12-26
P-790	3-3, 3-29, 3-41 14-29, 15-42, 16-11	P-995	10-12	P-1203	6-13, 6-14, 6-18 35-4, 38-6
P-791	17A-41, 12-7, 12A-42 14-20	P-1000	7-16, 34-29	P-1218	58-2, 58A-14
P-792	12A-47	P-1009	7-40, 7A-6	P-1219	29C-11
P-802	31-4A	P-1011	59-5	P-1220	25-25, 58-33, 58A-31
P-808	10-26	P-1012	59-2	P-1221	25-7, 26-16, 26A-3 26A-8, 29A-13, 29A-25 29B-11, 29C-42, 34-3
P-809	10-22	P-1024	37-45	P-1222	28-7, 29B-33, 29C-34 32-17
P-811	56-4	P-1026	63-31	P-1223	9-18, 22-41, 23-48 34-23
P-812	39-2, 57A-10A, 56A-55 60-7 57A-10A	P-1027	16-5, 17-37	P-1224	18-20
P-813	12-23, 12-44	P-1034	62-27	P-1225	29B-32, 29C-33, 34-11 60-13
P-814	38-34A	P-1035	62-34	P-1233	26-21
P-817	35-34	P-1038	8-14, 59-31	P-1237	34-3
P-820	40-20	P-1039	13-9	P-1244	20-9, 39-35
P-822	11-26, 26-40, 32-24 32-31, 38-19, 44-28	P-1040	13-9, 13-10, 13A-6 13A-12	P-1246	57-16A
P-824	19-11, 45-10	P-1044	41-2, 42-13	P-1247	57-16
P-825	19-11, 45-10, 56-13	P-1048	53-12	P-1250	28-5
P-826	40-9, 43-25	P-1049	16-26	P-1260	34-11, 56-30A
P-827	54-35	P-1051	53-14	P-1261	24B-8A, 46-17, 60-6
P-828	44-4	P-1052	10-7, 16-32	P-1262	34-11
P-832	36-29	P-1053	15-29	P-1263	53A-24, 55-18
P-836	64-11	P-1054	1A-54, 1B-24, 1-20 55-21, 55A-10, 55A-20	P-1264	44-8, 55A-15, 55A-31 60-5, 60-11
P-839	31-12	P-1055	33-3	P-1268	9-27
P-849	57-14	P-1056	47-33	P-1269	39-10
P-851	22-21, 23-27	P-1057	39-20	P-1271	53-9
P-860	12A-6	P-1058	7-21, 7A-35	P-1299	57-2
P-870	25-1	P-1085	5-3	P-1304	8-10
P-872	13-23, 13A-25	P-1086	4-6	P-1305	42-43
P-875	2-5	P-1101	49-1	P-1313	60-12
P-892	16-29	P-1126	53-30	P-1315	21-13, 26-4
P-895	37-5	P-1139	47-37	P-1330	41-24
P-896	57-8, 62-1	P-1141	25-22	P-1331	31-36
P-897	34-33A	P-1144	2-14	P-1333	57A-5
P-910	13-5, 20-36, 25-15	P-1145	3-6	P-1340	26-50
P-929	17-46	P-1146	3-20	P-1341	24B-21
P-936	32-20, 58A-36	P-1147	3-19	P-1342	34-23
P-943	4-2, 4A-13, 7-25 10-13, 13A-20, 21-5 26-42, 46-33, 49-3 59A-30	P-1148	3-21, 3-29	P-1359	2-8
P-944	1A-18, 1-52, 11-31 45-17, 49-22, 50-4	P-1149	3-25	P-1362	42-43
P-945	7-11, 52-16	P-1150	3-22	P-1369	39-13
P-946	26-45, 28-6	P-1151	3-23, 3-29	P-1370	39-15
P-948	1B-22, 26-46	P-1152	3-24	P-1372	14-40
P-949	26-47, 28-9	P-1153	3-7	P-1379	33-24, 35-7, 38-8
P-951	2-10	P-1154	3-10	P-1380	12-24
		P-1155	3-9	P-1381	28-44
		P-1156	3-8	P-1382	25-23, 39-19
		P-1157	3-18	P-1383	18-3A
		P-1158	3-13		
		P-1159	3-5		
		P-1160	4-8, 4A-17, 5-2		
		P-1161	2-1		



# I N D E X

PART NO.#	PAGE & INDEX KEY NO.#	PART NO.#	PAGE & INDEX KEY NO.#	PART NO.#	PAGE & INDEX KEY NO.#
P-1389	55-5	P-1549	18-9	P-1680	2-4
P-1392	38-9	P-1550	42-20C	P-1690	34-26
P-1394	54-21	P-1552	9-15	P-1691	34-26
P-1395	54-20	P-1554	9-15	P-1692	34-26
P-1398	64-14	P-1555	9-16	P-1693	34-26
P-1403	31-18	P-1556	28-6	P-1694	34-26
P-1404	31-34	P-1557	45-27	P-1700	1-29, 1A-50, 2-6
P-1409	26-30	P-1558	62-27	P-1701	50-8
P-1412	12A-27	P-1559	53-33	P-1702	50-8
P-1413	20-13	P-1561	10-16	P-1703	50-8
P-1415	54-12	P-1563	49-25	P-1704	50-8
P-1416	54-12	P-1565	12-53	P-1705	50-8
P-1418	28-33	P-1566	11-13	P-1706	50-8
P-1419	18-22	P-1567	12-46	P-1707	50-7
P-1432	44-25	P-1568	28-28A	P-1708	50-8
P-1446	26-52	P-1569	28-28A	P-1709	50-8
P-1455	33-23, 35-6, 38-7	P-1570	29A-41, 29B-42 / 52, 29C-52 / 73	P-1710	50-8
P-1458	7-28			P-1711	50-8
P-1462	40-35, 43-7	P-1571	29A-41	P-1712	50-7
P-1463	5-28, 12-50, 12A-33 40-7, 43-26, 47-51	P-1573	16-45	P-1725	17A-7
		P-1574	13-26	P-1726	7A-28
P-1464	9-6	P-1575	15-12	P-1727	48C-23
P-1465	40-17	P-1576	41-15	P-1742	44-35, 52-33, 52-36
P-1467	20-13, 20-15	P-1578	20-14	P-1744	51-12
P-1468	12-25	P-1579	5-29, 12-49, 12A-32 47-52	P-1745	1B-47
P-1474	51-11			P-1746	1B-50
P-1475	62-40	P-1580	10-10	P-1747	48C-6
P-1476	38-17	P-1582	11-30, 19-6	P-1749	52-17
P-1483	37-31	P-1583	42-26	P-1751	1A-51
P-1484	37-2	P-1586	3-32	P-1752	39-58
P-1485	42-44	P-1587	3-31	P-1753	29C-37, 39-62
P-1488	7-42, 7A-8	P-1588	3-29, 3-30	P-1757	48C-33
P-1489	7-36	P-1589	9-35, 28-40, 36-20	P-1790	48C-30
P-1490	12A-26	P-1590	9-36, 25-42, 28-42 58-41, 59-38	P-1814	1B-51, 56A-47, 57-25
P-1492	12A-37			P-1815	35-40, 52-27
P-1493	35-31A	P-1591	11-13	P-1817	57-37
P-1494	26-53	P-1592	10-40, 21-22, 25-35	P-1821	13-25, 13A-17
P-1495	1B-2, 4A-18, 22-49 23-53, 29C-31, 36-32	P-1593	5-27, 12-51, 12A-34 47-50	P-1822	13-31, 13A-16
				P-1824	1-29
P-1499	50-11	P-1595	15-39, 38-36	P-1825	2-6
P-1500	1A-49, 1-35	P-1597	17-48	P-1826	17-5
P-1504	1A-3, 1-47	P-1599	2-8	P-1827	34-34
P-1505	53-32	P-1600	32-6, 33-21, 35-5	P-1829	63-14
P-1509	4A-19	P-1609	16-34	P-1833	50-13
P-1510	4-18	P-1610	16-33	P-1832	50-12
P-1511	4-23	P-1614	20-27, 60-15	P-1834	48A-10, 48B-17, 48C-5
P-1512	48A-22, 48A-40, 63-19	P-1615	57-47	P-1835	48A-4
P-1513	14-18	P-1630	1-32, 1A-51, 1B-14 1B-42	P-1836	48A-31
P-1515	5-3			P-1837	56A-4
P-1517	50-15	P-1631	1-32	P-1838	48B-15, 52-32
P-1518	48B-11, 48C-17	P-1634	1A-50, 2-6	P-1839	52-3, 56A-21
P-1521	62-12	P-1636	1A-50, 1B-18, 2-6	P-1840	56A-36, 63-19
P-1522	20-28	P-1637	2-4	P-1843	48B-23, 48C-31
P-1527	28-34	P-1638	2-4	P-1844	48B-5
P-1538	7A-19, 45-15	P-1639	2-4	P-1850	3-17
P-1539	7-1, 7-46, 7A-12	P-1640	2-4	P-1851	3-17A
P-1540	8-12, 8-39, 59-35 59A-18	P-1641	62-28	P-1900	18-2, 50-17
		P-1642	2-8	P-1901	18-2
P-1541	62-23	P-1644	1-30, 1A-56, 2-18, 48B-20, 48C-7	P-1903	18-3
P-1543	14-15			P-1915	18-1
P-1544	8-41	P-1645	3-15	P-1919	18-1
P-1545	9-4	P-1647	62-29	P-1940	9-5
P-1546	8-54, 9-38, 10-41 12-52, 19-38, 20-38 21-21, 22-45, 23-50 25-41, 28-41, 29B-44 29C-61, 36-35, 44-32 53-34, 58-42, 59-39	P-1649	1-32, 1A-51	P-1951	50-5, 58-30
		P-1658	57-28	P-1972	2-6
P-1547	21-23, 22-47, 23-51 29B-45, 29C-62, 44-23	P-1661	52-34	P-1975	3-35
		P-1672	63-22	P-1994	1A-24, 1B-1
P-1548	18-7	P-1673	62-33	P-3001	54-7
		P-1674	62-32	P-3002	62-13
		P-1675	63-22	P-3003	59-30
		P-1676	64-5	P-3004	59-9
		P-1679	1B-13	P-3008	40-44

# I N D E X

PART NO.#	PAGE & INDEX KEY NO.#	PART NO.#	PAGE & INDEX KEY NO.#	PART NO.#	PAGE & INDEX KEY NO.#
P-3010	29C-5	P-5028	25-46	P-6021	35-20
P-3011	51-36	P-5029	25-46	P-6022	40-2
P-3012	62-41	P-5118	3-45	P-6023	6-24, 35-43
P-3014	57A-20	P-5316	3-44	P-6024	40-30, 43-29
P-3023	15-47	P-5319	3-43	P-6025	43-16
P-3066	9-31	P-5331	50-19	P-6026	48-9
		P-5334	53A-7	P-6027	36-22
P-3075	42-2	P-5335	53A-2	P-6028	37-29
P-4003	48A-29	P-5336	57A-6	P-6029	37-30
P-4004	48A-30, 48A-32	P-5337	58A-12	P-6030	37-6
P-4006	1-31, 1A-55, 1B-19, 2-11	P-5353	56A-17, 57A-17, 62-38	P-6031	42-39
P-4007	63-21	P-5356	57A-20	P-6032	47-15
P-4008	63-20	P-5364	1B-49	P-6033	38-30
P-4010	48B-7	P-5365	25-44	P-6034	38-35
P-4019	48B-27	P-5368	25-49	P-6035	6-18, 39-50
P-4021	48C-11	P-5375	51-24	P-6037	39-7
P-4026	47A-18	P-5376	55A-27	P-6038	39-33
P-4027	37-46	P-5377	59-32	P-6040	12A-25
P-4028	37-47	P-5379	55A-29	P-6042	12A-14, 12A-28
P-4029	40-43	P-5502	52-27A	P-6043	12A-44
P-4030	47A-19	P-5507	57A-10	P-6044	7A-21
P-4032	52-19	P-5509	59A-29	P-6045	7A-21
P-4033	47A-19	P-5511	58A-2	P-6047	38-30
P-4034	47A-20	P-5512	59A-38	P-6048	40-39
P-4035	51-23	P-5513	62-36	P-6049	40-38
P-4036	48C-36	P-5703	56A-29	P-6050	43-16
P-4037	48C-29	P-5802	1B-30	P-6051	16-16
P-4038	48C-41	P-5803	52-15	P-6052	16-9, 17A-26
P-4039	48C-13	P-5809	24B-21	P-7000	22-27, 23-11
P-4041	48C-16	P-5810	56A-11, 57A-15, 59A-2	P-7001	26-39
P-4042	48C-20	P-5811	56A-15	P-7002	58-25, 58A-22, 59-21
P-4043	48C-22	P-5812	56A-16		59A-7
P-4044	48C-21	P-5813	58A-11	P-7003	35-9, 38-22
P-4045	48C-29	P-5814	58A-30	P-7004	62-26
P-4046	48C-34	P-5815	62-46	P-7005	61-17, 63-34
P-4047	52-31	P-5841	21-13	P-7006	61-19, 63-35
P-4048	52-9	P-5912	36-21	P-7007	55-14, 61-14A, 61-14B
P-4049	52-9	P-5951	20-37, 42-20C		63-36
P-4057	47A-51	P-5952	19-37	P-7008	61-18, 63-37
P-4065	48C-19	P-5955	50-24	P-7009	60-16
P-4066	48C-19	P-5956	50-21	P-7010	56-43
P-4088	1B-18A	P-5957	50-22	P-7011	7-38, 7A-4
P-4089	56A-2	P-5958	50-23	P-7014	26-39
P-4090	56A-25	P-5959	50-25	P-7016	39-22
P-4328	54-20	P-5960	50-26	P-7017	46-46
P-4400	29B-41	P-5961	8-55	P-7018	51-38
P-4418	48B-26	P-5962	50-27	P-7019	48C-25
P-4917	1B-52, 34-26	P-5974	13-22	P-7020	48C-28
P-5001	30-1	P-5967	13-33	P-7021	29C-16
P-5002	30-2	P-6000	10-19	P-7022	29C-14
P-5003	30-3	P-6001	10-23, 17-27	P-7024	53A-30
P-5004	30-4	P-6002	16-9	P-8000	10-24
P-5005	30-5	P-6004	12-17	P-8001	10-20
P-5006	30-6	P-6005	12-17	P-8002	19-9
P-5007	30-7	P-6006	12-32, 12A-45	P-8003	20-12
P-5008	30-8	P-6007	14-5, 24A-6, 24B-13	P-8004	17-24
P-5009	30-9, 30A-11, 30A-16		29A-18, 29B-19, 35-15	P-8005	26-29
P-5010	30A-10, 30A-11, 30A-16	P-6008	15-48	P-8006	23-18
			58A-2	P-8007	24A-1
P-5011	30A-11	P-6009	7-2, 7A-18	P-8008	28-8
P-5012	30A-12, 30A-16, 30A-17	P-6010	5-18, 40-38, 43-10	P-8009	28-10, 37-9
P-5013	30A-13, 30A-15, 30A-17		46-39, 60-9	P-8010	28-34
P-5014	30A-14, 30A-15, 30A-17	P-6011	9-31	P-8011	29A-23, 29B-20
P-5015	30A-15	P-6012	16-16, 17-26	P-8012	37-9, 45-3, 46-1
P-5016	30A-16	P-6013	17-25		56A-9
P-5017	30A-17	P-6014	17-50	P-8013	46-18
P-5018	30A-17	P-6015	20-2	P-8014	5-20, 29B-36, 29C-48
P-5020	30A-12, 30A-17	P-6016	31-24		31-43
P-5021	30-1, 30A-17	P-6017	31-24	P-8015	46-23, 63-10
P-5022	30-5, 30A-17	P-6018	31-24	P-8016	46-25
P-5023	65-4	P-6019	31-23	P-8017	39-66, 46-31
		P-6020	32-2		

# I N D E X

PART NO.#	PAGE & INDEX KEY NO.#	PART NO.#	PAGE & INDEX KEY NO.#	PART NO.#	PAGE & INDEX KEY NO.#
P-8018	31-42	P-9037	47-43	P-35271	15-14
P-8019	36-19	P-9038	39-48	P-35273	15-16
P-8020	40-8, 43-27	P-9039	47-47	P-35275	15-16
P-8021	40-16	P-9040	39-22	P-35277	15-17
P-8022	40-34, 43-8	P-9041	39-22	P-35279	15-17
P-8023	41-17	P-9042	53-23	P-35281	15-20
P-8024	45-20	P-9043	54-9B	P-35283	15-23
P-8025	45-20	P-9044	59-3	P-35285	15-24
P-8026	45-20	P-9046	63-10A	P-35287	15-25
P-8027	39-30	P-9047	42-31	P-35289	15-26, 28-26
P-8028	8-37	P-9052	54-9B	P-35291	15-28
P-8029	9-5	P-9053	12A-23	P-35293	15-30
P-8031	53-16	P-9056	26A-14	P-35297	15-34
P-8032	54-14	P-9057	26A-17	P-35298	14-33
P-8033	54-29	P-9751	37-47	P-35299	15-35
P-8034	55-13	P-9782	48B-28	P-35301	15-36
P-8035	57-4	P-9806	47A-52	P-35307	15-37
P-8036	8-24, 55A-18, 57A-1 58-26, 58A-28	P-9818	37-48	P-35309	15-40
P-8038	5-20	P-10345	52-31A	P-35310	15-41
P-8039	60-1	P-10632	53-21	P-35311	15-41
P-8041	42-30	P-10787	3-38	P-35339	12-2
P-8042	17A-21	P-10886	11-7A	P-35364	19-16
P-8044	7-44, 7A-14	P-10981	3-40	P-35444	21-15, 25-21, 26-8
P-8045	4A-8, 22-3, 23-3B, 36-34	P-11644	8-38	P-35446	21-15
P-8046	25-29	P-11821	3-39	P-35450	21-14
P-8049	37-45	P-30006	50-9	P-35510	25-9
P-8050	38-33	P-30052	50-20	P-35514	25-10A
P-8052	45-3	P-30053	50-20	P-35518	25-10
P-8053	45-26, 46-47	P-30054	50-20	P-35528	25-18
P-8054	45-34	P-30055	50-20	P-35533	24B-1
P-8055	45-35	P-30056	50-20	P-35534	25-19
P-8056	14-45, 29C-29	P-30057	50-20	P-35541	24B-2
P-9000	13-6, 13A-9	P-30059	50-20	P-35663	46-4
P-9001	12-13	P-30200	25-50	P-35978	12-3
P-9002	5-14	P-30312	3-36	P-36001	2-15
P-9003	5-6	P-30314	3-29A	P-36002	2-19
P-9004	5-6	P-35000	27-4	P-36007	1-27, 2-7
P-9005	35-13	P-35010	22-7, 23-21, 30-9, 30A-13	P-36008	2-13
P-9006	36-13	P-35011	23-21, 24A-5, 30A-13	P-36009	2-16
P-9007	40-5	P-35018	50-10	P-36010	22-7, 23-21, 30-1 30-2, 30-4
P-9008	35-47	P-35020	26-48	P-36011	23-21, 24A-5, 30-4
P-9009	41-14	P-35021	26-48, 27-2, 30-9, 30A-13	P-36012	1-36
P-9010	41-14	P-35022	26-48, 27-3	P-36013	1-43
P-9011	41-14A	P-35029	28-1, 30A-10, 30A-14	P-36014	1-48, 8-20, 58-37, 58A-26
P-9012	41-14B	P-35030	28-20, 30-9, 30A-13	P-36015	1-55
P-9013	41-14C	P-35035	29A-26, 30A-10	P-36016	1-59
P-9014	41-14D	P-35050	18-14, 30A-12	P-36017	2-12
P-9015	6-7	P-35079	29A-39	P-36018	50-10
P-9016	42-10	P-35080	PAGE 27	P-36019	50-10
P-9017	6-22	P-35084	29A-40	P-36020	26-48
P-9018	42-19	P-35085	21-10	P-36021	26-48, 27-2, 30-2 30-4
P-9019	42-20A	P-35095	29B-40	P-36022	26-48, 27-3
P-9020	42-20B	P-35098	34-31	P-36025	1-43, 1A-2
P-9021	42-22	P-35163	11-32, 12-1	P-36026	1-8
P-9022	42-23A	P-35190	13-13	P-36027	48A-25A, 48B-21, 48C-35
P-9023	42-23B	P-35217	15-21	P-36028	1-9, 1A-40
P-9024	42-23C	P-35225	12-34	P-36029	28-1, 30-2, 30-5
P-9025	42-23D	P-35241	12-41	P-36030	28-20, 30-1, 30-2, 30-4
P-9026	42-31	P-35246	14-25	P-36031	1A-38
P-9027	42-32A	P-35253	15-1	P-36032	5-17, 9-34, 15-38 16-24, 38-24, 40-3, 43-9
P-9028	42-32B	P-35254	13-28	P-36033	3-28
P-9029	42-32C	P-35255	15-2	P-36034	1-12, 1A-42
P-9030	42-32D	P-35257	15-4	P-36035	29A-26
P-9031	37-14	P-35259	15-5	P-36036	1-16, 49-27
P-9032	43-18, 46-40	P-35261	15-5	P-36037	1-18, 1A-34
P-9033	43-28	P-35263	15-6	P-36038	1-19
P-9034	38-33	P-35265	15-7		
P-9035	38-60	P-35267	15-9		
P-9036	38-42	P-35269	15-10		

# I N D E X

PART NO.#	PAGE & INDEX KEY NO.#	PART NO.#	PAGE & INDEX KEY NO.#	PART NO.#	PAGE & INDEX KEY NO.#
P-36039	1-22, 1A-37	P-36109	8-18	P-36180	13-14
P-36040	1-3, 49-26	P-36110	8-20	P-36181	11-21
P-36041	1-7, 1A-31	P-36111	8-22	P-36182	13-15
P-36044	1-26, 1A-48, 49-29	P-36112	8-23	P-36183	11-25
P-36045	1-26, 1A-48, 49-29	P-36113	7-35	P-36184	13-16, 13A-15
P-36046	1-62, 1A-15	P-36114	8-28	P-36185	11-29
P-36047	1-54, 1A-16, 46-37	P-36115	8-30	P-36186	13-16, 13A-15
P-36048	1-55, 1A-10	P-36116	8-31	P-36187	12-5
P-36049	1-48, 1A-5	P-36117	8-33	P-36188	13-4, 13A-4
P-36050	18-14, 30-7	P-36118	8-34	P-36189	12-9, 12A-38
P-36051	1-49, 1A-4	P-36119	8-35	P-36190	13-13
P-36052	1-57, 1A-13	P-36120	8-35	P-36191	12-10, 12A-39
P-36053	1-36, 1A-1	P-36121	8-36	P-36193	12-12
P-36054	1-59, 1A-12	P-36122	8-43	P-36194	13-3A, 13A-3
P-36055	19-16, 19-34	P-36123	8-44	P-36195	13-3B, 13A-2
P-36056	7-23	P-36124	8-45	P-36196	13-7
P-36057	1-58, 1A-14	P-36125	8-46	P-36197	48-32
P-36058	1-61, 1A-26	P-36126	9-1	P-36198	13-7
P-36059	19-24, 21-14	P-36127	9-2	P-36199	48-29
P-36060	1-38, 8-48, 48-38	P-36128	9-3	P-36200	48-30
	57-30, 61-25	P-36129	9-23A	P-36201	48-31
P-36061	1-40, 8-50, 48-40	P-36130	9-24	P-36202	13-8, 13A-7
	57-33	P-36131	9-30	P-36203	12-18
P-36062	1-42, 1A-23, 1B-7	P-36132	9-26	P-36204	13-22, 13A-26
	6-11, 8-52, 18-24A	P-36133	9-29	P-36205	12-20
	20-32, 29C-3, 48-42	P-36134	10-15	P-36206	13-8
	57-31	P-36135	10-21	P-36207	12-21
P-36063	4A-11	P-36136	10-32	P-36208	13-11, 13A-11
P-36064	4A-14, 46-38	P-36137	10-25	P-36209	12-22
P-36065	4-11	P-36138	10-1	P-36210	13-18
P-36066	48A-12	P-36139	10-2	P-36211	13-12
P-36067	7-47, 7A-13	P-36140	10-5	P-36212	13-12
P-36068	4-17	P-36141	10-4	P-36213	12-28, 12A-46, 35-14
P-36069	4-20	P-36142	10-8		43-9A
P-36070	8-1	P-36143	10-8	P-36214	13-12
P-36072	29A-32	P-36144	10-42	P-36215	12-29
P-36073	5-7	P-36145	10-11	P-36216	48A-24
P-36074	4-26, 49-28	P-36146	10-29	P-36217	12-31
P-36075	29A-35	P-36147	11-1	P-36218	7-45, 7A-11
P-36076	5-19	P-36148	10-29	P-36219	9-33
P-36077	5-22	P-36149	11-2	P-36220	7-41, 7A-7
P-36078	5-26	P-36150	10-31	P-36221	7-44, 7A-10, 12-32
P-36079	29A-39	P-36151	11-5	P-36222	7-37
P-36080	PAGE 27	P-36152	7-26	P-36223	7A-17
P-36081	7-27	P-36153	11-9	P-36224	12A-8
P-36082	29A-38, 29B-53	P-36154	10-34	P-36225	12-34
P-36083	7-32	P-36155	11-16	P-36226	29B-38
P-36084	29A-40, 29B-41 / 55	P-36156	10-35	P-36227	29B-37
P-36085	21-10	P-36157	11-17	P-36229	12-35
P-36086	7-24	P-36158	10-37	P-36231	12-36
P-36087	7-6, 7A-15	P-36159	11-18	P-36233	29A-39, 29B-54
P-36088	7-15, 7A-32	P-36160	10-38	P-36234	14-34
P-36089	7-14, 7A-31	P-36161	11-19	P-36235	12-37
P-36090	7-20, 7A-34	P-36162	10-30	P-36236	14-36
P-36091	29B-35	P-36163	11-32, 12-1	P-36237	12-39
P-36092	7-17	P-36164	9-9	P-36238	14-38
P-36093	7-12	P-36165	11-32, 12-1	P-36239	29C-58
P-36094	7-12	P-36166	9-10	P-36240	14-39
P-36095	29B-40	P-36167	7A-36, 9-17	P-36241	12-41
P-36096	7-8	P-36168	9-11	P-36242	14-43, 29A-14, 29B-1
P-36097	29B-34	P-36169	9-23	P-36243	49-6
P-36098	7-22	P-36170	9-12	P-36244	14-44, 22-45, 29A-15
P-36100	7-19	P-36171	11-3		29B-2
P-36101	8-3	P-36172	9-13	P-36245	12-43
P-36102	8-4	P-36173	4-25	P-36246	13-1, 14-25
P-36103	8-5	P-36174	9-14	P-36247	12-47
P-36104	8-9	P-36175	11-12	P-36248	29B-7, 29C-7
P-36105	8-11, 59-34, 59A-17	P-36176	9-17	P-36249	12-48
P-36106	8-13, 59A-20	P-36177	11-8, 53-22, 53A-10	P-36250	13-29
P-36107	8-16	P-36178	13-3	P-36251	29B-9
P-36108	8-17	P-36179	11-15	P-36252	13-19

# I N D E X

PART NO.#	PAGE & INDEX KEY NO.#	PART NO.#	PAGE & INDEX KEY NO.#	PART NO.#	PAGE & INDEX KEY NO.#
P-36253	16-1	P-36331	16-7A, 17-17	P-36406	20-8
P-36254	29B-10	P-36332	18-17	P-36407	22-5, 23-4
P-36256	13-20	P-36333	16-36, 17-11	P-36408	20-26
P-36257	29B-15, 29C-15	P-36334	18-25	P-36409	48B-12
P-36258	13-21	P-36335	16-40, 17-16	P-36410	1-41, 1A-22, 1B-8
P-36259	29B-18	P-36336	18-26		6-10, 8-51, 18-32
P-36260	29B-26, 29C-41	P-36337	16-39, 17-15		20-30, 29C-2, 48-41
P-36261	29B-27, 29C-40	P-36338	18-29		57-32
P-36262	29B-28, 29C-38	P-36339	12-2	P-36411	22-9, 23-20
P-36263	29B-24	P-36340	18-30	P-36413	21-19, 22-10
P-36264	29A-22, 29B-21	P-36341	16-35	P-36414	48B-13, 48C-39
P-36266	14-4, 35-51, 38-48	P-36342	18-14, 19-27	P-36415	22-11
P-36266	39-12, 43-21	P-36344	19-3A	P-36416	20-29
P-36267	29A-6	P-36345	16-31	P-36417	22-14, 23-29
P-36268	29A-5	P-36346	19-4A	P-36418	20-31
P-36269	29A-3	P-36347	16-18	P-36419	22-17, 23-24
P-36270	14-6, 18-24, 29A-1	P-36348	19-3	P-36420	20-34
	29B-5, 38-31, 58-14	P-36349	16-19	P-36421	22-18, 23-25
P-36271	48A-43	P-36350	19-4	P-36422	20-34
P-36272	14-2	P-36351	16-22	P-36423	22-19
P-36273	29B-31, 29C-32	P-36352	16-17	P-36425	22-22, 23-12
P-36274	14-8	P-36353	16-23	P-36426	21-1
P-36275	29B-31	P-36354	16-42	P-36427	22-22, 23-12
P-36276	14-9	P-36355	29A-21, 29B-22	P-36428	21-2
P-36277	48B-14	P-36356	19-39	P-36429	22-23, 23-9
P-36278	14-11	P-36357	16-30	P-36430	21-4
P-36279	29A-42	P-36358	19-10	P-36431	22-24, 23-8
P-36280	14-14	P-36359	16-30	P-36432	21-6
P-36281	29B-46	P-36360	19-10, 45-9	P-36433	21-15, 25-36
P-36282	14-16	P-36361	29A-16, 29B-3	P-36434	21-7
P-36283	14-19A	P-36362	29A-12	P-36435	22-29
P-36284	14-24	P-36363	17-2	P-36436	21-9
P-36286	14-24	P-36364	19-16, 30-7, 30A-12	P-36437	22-31
P-36288	14-21	P-36365	17-3	P-36438	21-9
P-36289	5-8	P-36366	19-15, 19-32	P-36439	22-31
P-36290	14-26	P-36367	17-4	P-36440	21-12
P-36292	14-27	P-36368	19-21	P-36441	22-32
P-36293	48A-2	P-36369	17-9	P-36442	28-12
P-36294	14-28	P-36370	19-18, 19-35	P-36443	21-12B
P-36295	14-28A	P-36372	19-19	P-36444	21-15, 26-8
P-36296	14-33	P-36374	19-23	P-36445	22-37
P-36298	14-33	P-36375	17-29	P-36446	22-40, 23-47, 25-30
P-36299	16-28	P-36376	19-28	P-36447	22-34
P-36300	20-3	P-36376-K	19-40	P-36448	21-18, 26-14, 26A-1
P-36301	7-29	P-36377	17-30	P-36449	22-43, 23-49
P-36302	14-32	P-36378	19-25, 21-16	P-36450	21-14
P-36303	48A-26, 48B-19, 48C-10	P-36379	17-34	P-36451	22-39
P-36304	18-4	P-36381	17-39	P-36452	39-18
P-36305	48A-26, 48B-10	P-36382	20-6	P-36453	21-12A
P-36306	48A-28	P-36383	17-40	P-36454	39-21
P-36307	48B-10A	P-36384	20-21	P-36455	22-40, 23-47, 25-30
P-36309	16-44	P-36385	17-41	P-36456	26-17, 26A-4A
P-36311	16-10	P-36386	20-22	P-36457	22-40, 23-47, 25-30
P-36312	17-26A	P-36387	17-42	P-36458	26A-18
P-36313	15-44, 16-13, 17-21	P-36388	48B-1	P-36459	26A-20
P-36315	15-46, 16-15	P-36389	17-44	P-36460	26-10
P-36316	18-5	P-36390	48B-3	P-36462	26-11
P-36317	29A-24	P-36391	17-45	P-36463	26-7
P-36318	18-5	P-36392	48B-4	P-36464	26-13
P-36319	29A-30	P-36393	17-49	P-36465	22-38
P-36320	18-18A	P-36394	20-17	P-36466	26-15, 26A-2
P-36321	18-19A	P-36395	48B-22	P-36467	48B-2
P-36322	18-12	P-36396	20-18	P-36468	26-20, 26A-7
P-36323	16-2A	P-36397	17-51	P-36469	22-33
P-36324	18-19	P-36398	20-18	P-36470	26-19
P-36325	16-4, 17-36	P-36399	4-15, 22-6, 23-5	P-36471	23-13
P-36326	18-18	P-36400	20-7	P-36472	26-11A
P-36327	16-6, 17-28, 39-16	P-36401	22-1, 23-1	P-36473	23-13
P-36328	18-15	P-36402	20-23	P-36474	26-23, 26A-10
P-36329	16-7B	P-36404	20-20	P-36475	23-16
P-36330	18-16	P-36405	22-4B, 23-3B	P-36476	26-25, 26A-12

# I N D E X

PART NO.#	PAGE & INDEX KEY NO.#	PART NO.#	PAGE & INDEX KEY NO.#	PART NO.#	PAGE & INDEX KEY NO.#
P-36477	23-16, 57A-13	P-36557	24B-8, 46-16	P-36633	46-4
P-36478	26A-6	P-36558	32-4	P-36634	32-25
P-36479	23-17	P-36559	24B-11	P-36635	45-2, 45-19, 46-6
P-36480	26-33	P-36560	28-39, 37-8		46-8
P-36481	23-17	P-36561	24B-12	P-36636	32-26
P-36482	26-28	P-36562	48A-17	P-36638	32-30
P-36483	23-17	P-36563	24B-18	P-36639	46-4, 46-7
P-36484	26-31	P-36564	28-31	P-36640	32-23, 44-27
P-36487	34-2, 49-28	P-36565	24B-19	P-36641	45-5, 46-5
P-36488	48B-7	P-36566	48A-14	P-36642	32-27
P-36489	23-26	P-36567	24B-20, 46-14	P-36643	45-2, 46-6
P-36490	26-32	P-36568	28-35	P-36644	32-28
P-36491	23-26	P-36569	28-28B	P-36645	45-5, 45-19, 46-5
P-36492	26-41	P-36570	28-29		46-8
P-36493	23-35	P-36571	24B-22, 45-37, 46-13	P-36646	32-30
P-36494	26-44	P-36572	28-27	P-36647	46-7
P-36495	23-36	P-36573	24B-23	P-36648	33-8
P-36496	25-6	P-36574	32-3	P-36649	46-7
P-36497	23-30	P-36576	28-29A	P-36650	33-11
P-36498	25-4	P-36577	34-4	P-36651	46-7
P-36499	23-38	P-36578	28-35	P-36652	33-19
P-36500	28-32A	P-36579	24B-24	P-36653	56A-34
P-36501	28-32B	P-36580	28-23	P-36654	33-33, 56A-35, 63-33
P-36502	33-33	P-36581	34-5	P-36655	45-19, 46-8
P-36503	23-42	P-36582	31-2	P-36656	33-20
P-36504	25-24	P-36583	34-6	P-36657	33-35
P-36505	23-46	P-36584	31-4	P-36658	33-33, 56A-35, 63-33
P-36506	25-26	P-36585	34-10	P-36659	45-19, 46-8
P-36507	25-3	P-36586	31-3	P-36660	33-14, 39-5
P-36509	23-33	P-36587	34-21	P-36661	54-34
P-36510	25-9	P-36588	31-13	P-36662	33-27
P-36511	24A-4	P-36589	34-12	P-36663	46-19
P-36512	25-14	P-36590	31-6	P-36664	33-28
P-36513	24B-14	P-36591	34-15	P-36665	46-19
P-36514	48A-6	P-36592	31-15	P-36666	33-29
P-36515	24A-7	P-36593	34-16	P-36667	46-20
P-36516	25-10C	P-36594	31-7	P-36668	33-32
P-36517	24A-9	P-36595	34-17	P-36669	46-21
P-36518	48A-8	P-36596	31-8	P-36670	33-1
P-36519	48A-42	P-36597	34-12	P-36671	46-22
P-36520	25-10B	P-36598	31-16	P-36672	33-5
P-36521	24A-14	P-36599	34-21	P-36673	33-33, 56A-35
P-36524	25-13	P-36600	31-19	P-36674	33-6
P-36525	24A-18	P-36601	34-22	P-36676	33-7
P-36526	25-17	P-36602	31-11	P-36677	46-27
P-36529	25-18	P-36603	34-24	P-36678	33-10
P-36530	25-18A	P-36604	31-25	P-36679	46-28
P-36531	24A-15	P-36605	34-25	P-36680	33-15
P-36532	25-19A	P-36606	16-2	P-36682	33-18
P-36533	24B-1	P-36607	31-40	P-36683	46-32
P-36534	28-1A	P-36608	31-13	P-36684	28-18
P-36535	54-34	P-36609	31-40	P-36685	46-35
P-36536	25-29	P-36611	31-31	P-36687	36-2
P-36538	28-13	P-36612	31-33	P-36688	36-1A
P-36539	46-41	P-36613	31-35	P-36689	36-1
P-36540	48A-42	P-36614	31-32	P-36690	35-12
P-36541	24B-2	P-36615	34-27	P-36691	36-4
P-36542	28-15	P-36616	31-1	P-36693	36-6
P-36543	18-33	P-36617	34-28	P-36694	35-36
P-36544	28-16	P-36618	31-41	P-36695	36-8
P-36545	46-49	P-36619	17-32, 37-35	P-36696	28-12
P-36546	48A-19	P-36620	31-41	P-36697	36-9
P-36548	28-4	P-36621	31-37	P-36698	35-19
P-36549	24A-17, 28-38	P-36622	32-5	P-36699	36-11
P-36550	28-36	P-36623	23-41	P-36700	46-44
P-36551	24B-3	P-36626	32-10	P-36702	35-26
P-36552	28-11	P-36627	24A-3	P-36703	36-16
P-36553	24B-4	P-36628	32-11	P-36704	35-23
P-36554	28-18	P-36629	24B-20	P-36706	7-3
P-36555	24B-6	P-36630	32-15	P-36707	6-11, 17A-29, 36-18
P-36556	28-19	P-36632	32-16	P-36708	35-28

# I N D E X

PART NO.#	PAGE & INDEX KEY NO.#	PART NO.#	PAGE & INDEX KEY NO.#	PART NO.#	PAGE & INDEX KEY NO.#
P-36709	35-3	P-36790	6-9	P-36874	45-21
P-36710	35-33	P-36791	42-7	P-36875	43-24
P-36711	7-5	P-36792	29A-34	P-36876	45-23
P-36712	7-18	P-36793	42-9	P-36877	49-16
P-36713	7-9	P-36794	6-8	P-36878	45-24
P-36714	35-42	P-36795	29B-50	P-36879	49-11
P-36715	40-6	P-36796	6-13	P-36880	49-10
P-36716	35-44	P-36797	42-11	P-36881	43-30
P-36717	41-3, 42-14	P-36798	6-23, 10-9, 43-12	P-36882	45-13
P-36719	40-14	P-36801	42-18	P-36883	43-31
P-36720	35-50, 39-42	P-36802	6-20	P-36884	45-13
P-36721	40-15	P-36804	37-40	P-36885	38-5
P-36722	35-48	P-36805	59B-47	P-36886	45-18
P-36723	44-18	P-36806	37-16	P-36887	49-9
P-36724	44-3	P-36807	29B-48	P-36888	47-21
P-36725	40-18	P-36808	37-20	P-36889	38-10
P-36726	44-7	P-36810	37-24	P-36890	47-6
P-36727	40-19	P-36811	7-49	P-36891	38-11
P-36728	44-11	P-36814	37-25	P-36892	47-5
P-36729	40-22	P-36815	42-22	P-36893	38-12
P-36730	41-22	P-36816	37-25	P-36894	47-7
P-36731	40-24	P-36817	48-6	P-36895	38-13
P-36732	44-5	P-36818	37-37	P-36896	47-8, 47A-15, 51-17
P-36733	40-25	P-36819	13-16	P-36897	38-15
P-36734	44-13	P-36820	37-22	P-36898	47-9, 47A-12
P-36735	40-26	P-36823	37-27	P-36899	38-16
P-36736	44-13	P-36824	37-28	P-36900	47-48, 47A-10, 51-13
P-36737	40-28	P-36826	48A-12	P-36901	38-18
P-36738	44-13	P-36825	48A-13	P-36902	47-10
P-36739	40-29	P-36827	43-1	P-36903	38-21
P-36740	44-31	P-36828	37-32	P-36904	47-11, 51-7
P-36741	44-17	P-36829	48A-11	P-36905	38-26
P-36742	44-19	P-36830	37-38	P-36906	47-16
P-36743	40-31	P-36831	42-25	P-36907	38-28
P-36744	41-23	P-36832	37-7	P-36908	47-6
P-36745	44-26	P-36833	42-27	P-36909	38-29
P-36747	40-36	P-36834	37-39	P-36911	16-10, 17-18
P-36748	44-26	P-36835	42-30	P-36912	47-5
P-36749	41-1	P-36836	37-13	P-36913	49-8
P-36750	44-22	P-36839	40-12	P-36914	47-13
P-36751	42-5	P-36841	4A-1	P-36915	38-34
P-36752	44-21	P-36842	37-3	P-36916	49-7
P-36753	41-4, 42-28	P-36844	4A-5	P-36917	49-5
P-36754	44-21	P-36845	4A-4	P-36918	38-53, 39-57
P-36755	41-4	P-36846	37-1	P-36919	39-1
P-36756	44-23	P-36847	4A-1	P-36920	47-18
P-36757	41-6, 42-15	P-36848	25-40	P-36921	38-38, 38-59
P-36758	44-23	P-36849	37-43A	P-36922	47-19, 47A-17
P-36759	41-6	P-36850	37-43B	P-36923	38-39
P-36760	4-27	P-36851	42-41	P-36924	47-19
P-36761	41-10	P-36852	37-33	P-36925	38-41
P-36763	41-10	P-36853	42-42	P-36926	47-20
P-36765	29B-29	P-36854	37-32	P-36927	39-9
P-36767	25-50	P-36855	42-3	P-36928	47-4
P-36769	6-28	P-36856	37-41	P-36929	38-43
P-36770	6-11	P-36857	42-47	P-36930	47-22
P-36773	25-43	P-36859	4A-3	P-36931	38-44
P-36774	25-48	P-36858	37-42	P-36931	38-44
P-36775	25-45	P-36860	37-43	P-36932	49-2
P-36776	25-47	P-36861	43-4	P-36933	38-47
P-36778	29A-31	P-36862	45-1	P-36935	38-61
P-36779	41-22	P-36863	38-11	P-36936	47-23
P-36781	41-20	P-36864	45-2	P-36937	39-31
P-36782	6-1	P-36865	43-15	P-36938	47-41
P-36783	41-19	P-36867	49-19, 60-31	P-36939	39-32
P-36784	6-27, 39-54	P-36868	45-22	P-36940	47-40
P-36785	48-8	P-36869	43-15	P-36941	39-11
P-36786	6-26, 39-53	P-36870	45-22	P-36942	47-42
P-36787	6-16, 39-49	P-36871	49-17, 60-26	P-36943	38-57
P-36788	6-5	P-36872	45-7	P-36944	39-6
P-36789	29A-32	P-36873	49-21	P-36945	38-58

# I N D E X

PART NO.#	PAGE & INDEX KEY NO.#	PART NO.#	PAGE & INDEX KEY NO.#	PART NO.#	PAGE & INDEX KEY NO.#
P-36946	29B-30, 29C-35, 39-41	P-37070	8-1	P-37364	19-16, 30A-12
P-36947	38-58	P-37072	29A-32	P-37374	19-23
P-36948	47-24	P-37075	29A-35	P-37378	19-25, 21-16
P-36949	38-59	P-37079	29A-39	P-37394	20-17
P-36950	47-35	P-37080	PAGE 27, 30A-12	P-37401	22-1, 23-1
P-36951	4A-2	P-37082	29A-38, 29C-70	P-37435	22-29
P-36952	47-28	P-37084	29A-40,29B-41,29C-51 / 72	P-37442	28-12
P-36953	17-1	P-37086	7-24	P-37450	21-14
P-36954	47-31	P-37093	7-12, 7A-16	P-37452	39-64
P-36955	39-36	P-37094	7-12, 7A-16	P-37456	26-17, 26A-4A
P-36956	47-30	P-37102	8-4	P-37470	26-19
P-36957	39-37	P-37103	8-5	P-37472	26-11A
P-36958	47-32	P-37108	8-17	P-37487	34-2
P-36959	29C-26, 39-39, 59-25	P-37112	8-23	P-37497	23-30
	59A-14	P-37113	7A-1	P-37499	23-38
P-36960	47A-16, 48-43, 51-18	P-37116	8-31	P-37509	23-33
P-36961	39-40, 59-24	P-37126	9-1	P-37510	25-9
P-36962	59-27, 59A-16	P-37127	9-2	P-37512	25-14
P-36963	47-32	P-37129	9-23A	P-37525	24A-16
P-36964	7-33	P-37133	9-29	P-37530	25-18
P-36965	39-43	P-37138	10-1	P-37533	24B-1
P-36966	9-14	P-37139	10-2	P-37541	24B-2
P-36967	39-44	P-37142	10-8	P-37544	28-16
P-36968	48-15	P-37147	11-1	P-37550	28-36
P-36969	39-45	P-37148	10-29	P-37554	28-18
P-36970	8-53, 59-35A, 59A-19	P-37149	11-2	P-37456	26A-4A
P-36971	48A-33	P-37154	10-34	P-37564	28-31
P-36973	39-28	P-37157	11-17	P-37568	28-35
P-36974	39-27	P-37159	11-18	P-37570	28-29
P-36975	39-25	P-37160	10-38	P-37573	24B-23
P-36976	13-13	P-37161	11-19	P-37582	31-2
P-36977	48A-26	P-37169	9-23	P-37583	34-6
P-36978	12-4	P-37180	13-14	P-37585	34-10
P-36979	39-34	P-37190	13-13	P-37594	31-7
P-36980	47-10	P-37196	13-7, 13A-5	P-37606	16-2
P-36981	48-1	P-37203	12A-7	P-37616	31-1
P-36982	47-1	P-37205	12A-35	P-37622	32-5
P-36983	17-18	P-37207	12A-22	P-37626	32-10
P-36984	47-49	P-37213	12-28, 43-9A	P-37633	46-4
P-36985	39-3	P-37222	7A-3	P-37634	32-25
P-36986	48-36	P-37225	12A-4	P-37635	26A-22, 45-2, 45-19
P-36987	48-17	P-37229	12A-9		46-6, 46-8
P-36988	47-49	P-37231	12A-12	P-37638	32-30
P-36989	48-19	P-37233	29A-39, 29C-71	P-37639	45-29
P-36990	9-14	P-37235	12A-11	P-37641	45-5, 46-5
P-36991	48-35	P-37241	12A-18	P-37647	46-7
P-36993	48-23	P-37245	12A-3	P-37648	33-8
P-36994	48-35	P-37247	12A-30	P-37655	46-42, 56A-8
P-36995	48-24	P-37249	12A-31	P-37663	46-4
P-36996	47-26	P-37252	13-19, 13A-21	P-37667	46-20
P-36997	48-25	P-37256	13-21, 13A-22	P-37669	45-29
P-36998	48-2	P-37258	13-20, 13A-23	P-37670	33-1
P-36999	48-14	P-37279	29A-42	P-37671	46-22
P-37001	2-15	P-37284	14-24	P-37677	46-27
P-37010	22-7, 30-1, 30-2, 30-4	P-37290	14-26	P-37678	33-10
P-37011	23-21, 24A-5, 30-1	P-37292	14-27	P-37689	36-1
P-37020	26-48	P-37301	7-29	P-37712	7-18, 7A-33
P-37021	26-48, 27-2, 30-1, 30-2	P-37308	13A-13	P-37713	7-9
P-37022	26-48, 27-3	P-37310	16-10	P-37723	44-18
P-37029	28-1, 30-2, 30-5	P-37311	16-10	P-37736	44-13
P-37030	58-20, 30-1, 30-2	P-37315	16-15, 17-22, 17A-50	P-37738	44-13
P-37032	12A-16	P-37323	16-2A	P-37740	44-31
P-37035	29A-26, 29B-29, 30-5	P-37332	18-17	P-37773	25-43
P-37036	1-16, 1A-32, 49-27	P-37334	18-25	P-37774	25-48
P-37038	1-19, 1A-35	P-37339	12A-43	P-37775	25-45
P-37039	8-17	P-37342	18-14, 19-27	P-37778	29A-31
P-37040	1-3, 1A-27, 49-26	P-37345	16-31	P-37779	41-22
P-37050	18-14, 30-7	P-37352	16-17	P-37781	41-20
P-37055	19-16, 19-34	P-37353	16-23	P-37783	41-19
P-37059	19-24, 21-14	P-37354	16-42	P-37789	29A-32
P-37064	4A-14, 46-38	P-37359	16-30	P-37795	29C-67



# I N D E X

PART NO.#	PAGE & INDEX KEY NO.#	PART NO.#	PAGE & INDEX KEY NO.#	PART NO.#	PAGE & INDEX KEY NO.#
P-37798	6-23, 10-9, 43-12	P-98213	17A-2	P-98517	51-1
P-37801	42-18	P-98214	13A-10	P-98518	51-5, 51-20
P-37827	43-1	P-98216	48C-1	P-98519	51-22
P-37846	37-1	P-98237	12A-13	P-98531	24B-26
P-37847	4-27	P-98242	14-43, 29C-30, 47A-1	P-98533	24B-1
P-37583	42-42	P-98251	29C-9	P-98540	51-22
P-37861	43-4	P-98259	29C-1, 47A-48	P-98541	24B-2
P-37862	45-1	P-98263	29C-56	P-98542	28-15
P-37873	49-21	P-98264	29C-19	P-98546	51-29
P-37879	49-11	P-98267	52-20	P-98550	28-36
P-37880	49-10	P-98269	10-45	P-98551	51-2
P-37887	49-9	P-98271	51-3	P-98552	28-11, 26A-15
P-37914	47-13	P-98279	29C-63	P-98555	28-45
P-37920	47-18	P-98280	52-25	P-98559	24B-11
P-37972	12A-43	P-98282	14-16	P-98560	26A-21
P-37976	12A-43	P-98283	52-20	P-98562	51-22
P-37992	12A-43	P-98288	29C-18	P-98565	24B-19
P-37981	4-1	P-98289	28-46	P-98566	51-25
P-37969	39-45	P-98293	48C-12	P-98570	28-29B
P-38157	11-17	P-98299	17A-34	P-98581	10-46
P-38290	14-26	P-98301	52-21	P-98583	34-6
P-38581	34-5	P-98302	52-35	P-98585	34-10
P-38955	39-36	P-98304	52-31B	P-98587	34-21
P-38957	39-37	P-98305	52-23	P-98597	34-12
P-98007	52-10	P-98303	52-22	P-98601	48C-15
P-98008	52-11	P-98307	17A-12	P-98615	34-27
P-98026	1B-31	P-98309	29C-20	P-98617	34-28
P-98028	1B-32	P-98311	17A-42	P-98633	46-4
P-98031	4A-9, 22-4C, 23-3C 36-33, 47A-21	P-98312	29C-12	P-98641	45-5, 46-5
P-98034	1B-37	P-98313	17A-48	P-98643	45-2, 46-6
P-98035	29C-39	P-98322	29C-36	P-98647	46-7
P-98038	1B-46	P-98323	17A-1	P-98654	37-51
P-98040	1A-27, 1B-26	P-98334	18-25	P-98657	56A-32
P-98041	1B-29, 1B-39	P-98336	18-26	P-98661	54-34
P-98043	1B-39	P-98339	12A-43	P-98667	46-20
P-98046	47A-14, 51-16	P-98347	17A-14	P-98671	46-22
P-98047	1B-12	P-98351	17A-27	P-98673	51-35
P-98051	1B-5	P-98352	17A-37	P-98681	46-32A
P-98053	1B-20	P-98353	17A-9	P-98683	46-32
P-98056	7-23	P-98359	17A-35	P-98684	46-32B
P-98058	1B-48	P-98361	52-25	P-98688	36-1A
P-98060	1A-20, 1B-6, 48-38	P-98362	29C-10	P-98689	36-1
P-98061	1A-21, 1B-9, 48-40	P-98365	17A-8	P-98691	36-4
P-98067	7A-20	P-98369	17A-43	P-98693	36-24
P-98070	8-1	P-98373	51-39	P-98695	36-8
P-98071	29A-31	P-98378	21-16	P-98697	36-8, 36-25
P-98082	29A-38	P-98379	17A-25	P-98700	35-26B
P-98087	7-24	P-98385	34-33	P-98701	52-5
P-98095	29C-50	P-98387	17A-20	P-98702	35-26A
P-98097	29C-47	P-98388	34-6	P-98706	7A-24
P-98098	7-22	P-98390	51-18	P-98708	35-28A
P-98102	8-4	P-98393	17A-36	P-98710	39-65
P-98106	59A-39	P-98395	34-36	P-98711	7A-22
P-98114	8-28	P-98398	34-37	P-98713	7A-26
P-98115	8-30	P-98403	29C-25	P-98717	41-3, 42-14
P-98119	8-30A	P-98409	48C-2	P-98723	44-18
P-98124	52-28	P-98410	48C-42	P-98728	44-13
P-98126	52-29	P-98416	47A-47	P-98730	41-22
P-98137	1B-37	P-98431	23-8	P-98731	40-42
P-98152	7A-30	P-98438	21-9	P-98733	40-25
P-98153	17A-19	P-98442	28-12	P-98735	40-45
P-98156	10-43	P-98445	17A-45	P-98736	44-13
P-98162	1B-15	P-98454	39-61	P-98738	44-13
P-98171	17A-24	P-98472	26A-6	P-98739	40-29
P-98175	17A-30	P-98479	23-17	P-98751	51-37
P-98181	17A-16	P-98481	23-17	P-98753	42-28
P-98183	35-27A	P-98482	26-28	P-98754	44-21
P-98190	13A-18	P-98484	26-31	P-98759	41-6
P-98191	12A-39	P-98487	34-40	P-98785	48-8
P-98210	13A-19	P-98492	46-48, 47A-22	P-98792	29CB-49, 29C-66
		P-98515	24B-25	P-98805	29C-64

# I N D E X

PART NO.#	PAGE & INDEX KEY NO.#	PART NO.#	PAGE & INDEX KEY NO.#	PART NO.#	PAGE & INDEX KEY NO.#
P-98807	29C-65	P-350831	25-18	P-361630	56-17
P-98811	7A-2	P-350840	26-1, 27-1	P-361640	55-20
P-98820	37-48	P-350850	30A-12	P-361650	56-19, 61-26
P-98827	43-1	P-360821	26A-4A	P-361660	57-1
P-98828	37-54	P-360830	25-16, 30-2, 30-5	P-361670	56-20
P-98829	51-25	P-360831	25-18	P-361680	57-3
P-98830	37-38	P-360840	26-1, 27-1	P-361690	56-21, 56A-41
P-98833	42-27	P-360850	21-10, 30-7	P-361710	56-22, 61-13
P-98834	37-39	P-360870	26A-4	P-361720	57-5
P-98846	37-1	P-360990	54-1	P-361730	56-25, 56A-38
P-98850	37-43B	P-361000	54-3	P-361740	57-6, 24A-13
P-98855	48C-46	P-361010	54-4	P-361750	56-26
P-98856	37-41, 47A-49	P-361020	54-6	P-361770	56-27
P-98857	42-47	P-361030	53-35	P-361780	57-9
P-98860	37-43	P-361039	54-9	P-361790	56-28
P-98861	43-4	P-361040	54-9A	P-361800	57-10, 61-7
P-98862	52-2	P-361060	54-14	P-361810	56-7
P-98865	29C-43	P-361070	54-15	P-361820	57-11
P-98867	49-19A, 59A-36	P-361080	54-16	P-361830	56-30
P-98873	49-19B	P-361090	54-17	P-361840	57-46
P-98886	52-7	P-361100	54-19	P-361860	57-12
P-98892	47A-3	P-361110	53-36	P-361870	56-34
P-98894	51-14, 47A-11	P-361120	53-46	P-361880	57-13
P-98897	29C-6	P-361130	55-12, 61-5	P-361890	56-36
P-98898	51-15, 47A-12	P-361140	53-1	P-361900	57-15
P-98900	47A-10	P-361150	54-22, 61-9	P-361910	56-37
P-98902	51-9	P-361160	53-5	P-361920	57-17, 61-22
P-98905	38-26A, 47A-32	P-361170	54-22, 61-9	P-361930	58-1
P-98907	38-62	P-361180	53-7	P-361940	57-18
P-98908	47A-2	P-361190	53-23	P-361950	56-40
P-98909	38-29	P-361200	53-8, 61-8	P-361960	57-19
P-98913	49-30	P-361210	54-24	P-361970	56-42
P-98914	47A-9	P-361220	53-10	P-361980	57-21
P-98919	39-63	P-361230	54-24	P-361990	58-4, 58A-15
P-98922	51-19	P-361240	53-13	P-362000	57-22
P-98927	39-59	P-361250	54-26, 61-6	P-362010	58-5, 58A-16
P-98928	47A-7	P-361260	53-15	P-362020	57-23
P-98930	47A-8	P-361270	54-26, 61-6	P-362030	58-10, 61-10
P-98932	49-2A	P-361280	53-44	P-362040	57-29A
P-98934	48-2	P-361290	54-27	P-362050	58-12, 58A-3
P-98937	39-31	P-361300	53-18	P-362060	53A-21, 57-26
P-98940	47A-31	P-361310	54-27	P-362070	58-13
P-98942	47A-22	P-361320	53-19	P-362080	57-29
P-98944	38-57, 39-6	P-361330	54-28	P-362090	59-1, 61-27
P-98945	38-58, 39-6	P-361340	53-20	P-362100	57-36, 61-12
P-98946	47A-30	P-361350	54-28	P-362110	58-16
P-98950	47A-42	P-361360	53-42	P-362120	57-29B
P-98955	39-36, 47A-27	P-361380	53-26	P-362130	58-17, 58A-8
P-98957	39-37	P-361390	54-19	P-362140	57-41
P-98960	48C-38	P-361400	55-3, 55A-7	P-362150	58-18
P-98961	39-40, 59A-15	P-361410	56-1	P-362160	57-42
P-98968	51-31	P-361420	55-4, 55A-6	P-362170	58-19, 58A-18
P-98969	39-45	P-361430	56-1	P-362180	57-43
P-98971	51-27	P-361440	55-6, 55A-5	P-362190	58-21
P-98972	12A-43	P-361450	56-2	P-362200	57-44
P-98973	39-28	P-361460	55-7, 55A-3, 61-1	P-362210	58-23
P-98974	10-47	P-361470	56-3	P-362220	61-3, 62-2
P-98975	39-25	P-361480	55-9	P-362230	58-24, 61-20
P-98976	12A-43	P-361490	56-3	P-362240	62-3
P-98980	47A-13	P-361500	53-10	P-362260	62-4
P-98981	48-1	P-361510	58-3	P-362270	53-48
P-98985	39-61	P-361520	55-12, 61-5	P-362280	62-8
P-98987	48-17	P-361530	56-29	P-362290	58-27
P-98990	9-14A	P-361550	56-9	P-362300	62-10
P-98992	12A-43	P-361560	57-28	P-362320	62-11
P-98995	48C-45	P-361570	56-10	P-362350	58-34, 61-11
P-98998	48-2	P-361580	55-15	P-362360	58-39, 58A-27
P-98999	51-32	P-361590	56-12	P-362370	58-35
P-120846	26-7	P-361600	55-16	P-362380	62-16
P-350820	24A-11, 26-1, 30A-10, 30-5	P-361610	56-12	P-362390	58-36
P-350830	25-16, 30A-10, 30A-14	P-361620	55-17	P-362400	62-17

# I N D E X

PART NO.#	PAGE & INDEX KEY NO.#	PART NO.#	PAGE & INDEX KEY NO.#	PART NO.#	PAGE & INDEX KEY NO.#
P-362410	59-6	P-371800	57-10	P-981380	53A-11
P-362420	62-21	P-371840	57-46	P-981420	55A-22
P-362430	59-7	P-371900	57-15	P-981430	56A-54
P-362440	62-22	P-371920	57-17	P-981480	55A-8
P-362470	59-11, 61-21	P-372040	57-29A	P-981500	55A-11
P-362480	62-24	P-372060	57-26	P-981510	58A-12
P-362490	59-13, 59A-5	P-372080	57-29	P-981520	55A-12
P-362500	62-25	P-372220	62-2	P-981600	55A-19
P-362510	59-14	P-372240	62-3	P-981620	55A-14
P-362530	59-15, 59A-8	P-372260	62-4	P-981630	56A-45
P-362540	64-1	P-372380	62-16	P-981640	55A-26
P-362550	59-16	P-372400	62-17	P-981650	56A-43
P-362560	53-1	P-372410	59-6	P-981660	57A-3
P-362570	59-18, 59A-10	P-372440	62-22	P-981750	56A-39
P-362590	59-19, 59A-12	P-372470	59-11	P-981800	57A-4
P-362600	63-1	P-372490	64-12	P-981810	56A-56
P-362620	63-2	P-372500	62-25	P-981830	56A-10
P-362630	59-22, 61-23, 61-24	P-372510	59-14	P-981870	55-34
P-362640	63-4	P-372540	64-1	P-981910	56A-26
P-362660	63-5	P-372560	64-3	P-981920	56A-27
P-362670	60-4, 65-2	P-372580	64-4	P-982090	59A-23
P-362680	63-8	P-372590	64-13	P-982100	53A-3, 53A-12, 56A-48
P-362690	65-3	P-372600	63-1	P-982150	58A-7
P-362700	63-8	P-372640	63-4	P-982160	57A-7
P-362710	59-26	P-372650	64-2	P-982190	58A-20
P-362720	63-9	P-372740	63-9	P-982300	62-10
P-362730	59-28	P-372770	64-8	P-982320	62-11
P-362740	63-9	P-372800	63-11	P-982350	58A-29, 61-11
P-362750	59-29	P-372840	63-12A	P-982360	53A-12
P-362760	63-10	P-372940	63-18	P-982370	58A-23
P-362780	63-11	P-372950	60-30	P-982380	62-16A
P-362800	63-11	P-363010	53-27	P-982400	58A-6, 62-17
P-362810	59-33	P-373170	53-31	P-982410	59A-33
P-362820	63-12A	P-380990	54-1	P-982420	62-21A
P-362840	63-12A	P-381040	54-18	P-982440	62-22
P-362850	60-10, 65-1	P-381060	54-5	P-982470	59A-3, 61-21
P-362880	61-15, 63-16	P-381070	54-15	P-982500	62-25
P-362890	60-20	P-381090	54-17	P-982530	59A-8
P-362900	61-16, 63-16	P-381160	53-5	P-982560	53A-14
P-362910	60-21	P-381600	55-16	P-982630	59A-13
P-362920	63-18	P-381640	55-23	P-982670	60-33
P-362930	56-39	P-381800	57-10	P-982850	60-34
P-362940	63-18	P-381900	57-15	P-983130	53A-8
P-362950	60-30	P-381920	57-17	P-984000	55A-30
P-363010	53-27	P-381940	57-18	P-984010	55A-28
P-363040	63-24	P-382140	57-50	P-984020	55A-16
P-363060	63-25	P-382160	57-48	P-984030	55A-23
P-363080	63-27	P-382200	57-49	P-984040	55A-24
P-363100	63-28	P-382220	62-2	P-984050	56A-1
P-363110	53-28	P-382400	62-17	P-984060	56A-3
P-363120	63-30	P-382410	59-6	P-984070	56A-7
P-363140	63-32	P-382420	62-21	P-984040	56A-13
P-363170	53-31	P-382440	62-22	P-984090	56A-20
P-363230	63-12B	P-382470	59-11	P-984100	56A-23
P-363240	63-38	P-382440	62-22	P-984110	56A-24
P-363250	63-12B	P-382480	62-24	P-984120	56A-40
P-363270	59-36	P-382500	62-25	P-984121	56A-40
P-370820	24A-11, 30-5	P-382510	59-14	P-984130	57A-11
P-370821	26A-4A	P-382600	63-1	P-984140	57A-18
P-370830	25-16, 30-5	P-382740	63-9	P-984150	57A-23
P-370831	25-18	P-382940	63-18A	P-984160	56A-51
P-370845	27-5, 26-11A	P-382950	60-30	P-984170	57A-27
P-370850	30A-12	P-383010	53-27	P-984180	57A-8
P-370870	26A-4	P-882440	62-22	P-984200	58A-6
P-371030	53-35	P-980990	54-1	P-984210	59A-3, 61-21
P-371050	53-41	P-981039	54-9	P-984220	59A-24
P-371160	53-5	P-981040	54-9A	P-984230	59A-26
P-371220	53-10	P-981160	53A-15	P-984240	59A-27
P-371280	53-44	P-981240	53A-23	P-984250	59A-28
P-371460	64-15	P-981320	53A-6	P-984260	62-48
P-371600	55-16	P-981340	53A-9	P-984270	62-17A

# I N D E X

PART NO.#	PAGE & INDEX KEY NO.#	PART NO.#	PAGE & INDEX KEY NO.#	PART NO.#	PAGE & INDEX KEY NO.#
P-984279	62-39				
P-984280	62-39				
P-984289	62-43				
P-984290	62-43				
P-984300	62-44				
P-984310	62-47				
P-984320	62-21				
P-9881040	54-18				